

Installation assistance available at:

RFTECH

www.rockfordfosgate.com/rftech

P U N C H[®]



WAKE TOWER
SPEAKERS

PM282W • PM282W-B
PM282HW • PM282HW-B



Serial Number: _____ Date of Purchase: _____

600 South Rockford Drive • Tempe, Arizona 85281 United States
Direct: (480) 967-3565 • Toll Free: (800) 669-9899

ROCKFORDFOSGATE.COM



Installation & Operation

Dear Customer,

Congratulations on your purchase of the world's finest brand of audio products. At Rockford Fosgate we are fanatics about musical reproduction at its best, and we are pleased you chose our product. Through years of engineering expertise, hand craftsmanship and critical testing procedures, we have created a wide range of products that reproduce music with all the clarity and richness you deserve.

For maximum performance we recommend you have your new Rockford Fosgate product installed by an Authorized Rockford Fosgate Dealer, as we provide specialized training through Rockford Technical Training Institute (RTTI). Please read your warranty and retain your receipt and original carton for possible future use.

Great product and competent installations are only a piece of the puzzle when it comes to your system. Make sure that your installer is using 100% authentic installation accessories from Rockford Fosgate in your installation. Rockford Fosgate has everything from RCA cables and speaker wire to power wire and battery connectors. Insist on it! After all, your new system deserves nothing but the best.

To add the finishing touch to your new Rockford Fosgate image, order your Rockford accessories, which include everything from T-shirts to hats.

Visit our web site for the latest information on all Rockford products;

www.rockfordfosgate.com

or, in the U.S. call 1-800-669-9899 or FAX 1-800-398-3985. For all other countries, call +001-480-967-3565 or FAX +001-480-966-3983.

Table of Content

- 2 Introduction
- 3-4 Specifications
- 5 Installation
 - Installation Considerations
 - Mounting
- 6-7 Additional Languages
 - French
 - Spanish
 - German
 - Italian
- 8 Limited Warranty Information

If, after reading your manual, you still have questions regarding this product, we recommend that you see your Rockford Fosgate dealer. If you need further assistance, you can call us direct at **1-800-669-9899**. Be sure to have your serial number, model number and date of purchase available when you call.

PRACTICE SAFE SOUND

Continuous exposure to sound pressure levels over 100dB may cause permanent hearing loss. High powered auto sound systems may produce sound pressure levels well over 130dB. Use common sense and practice safe sound.

PRATIQUEZ UNE ÉCOUTE SANS RISQUES

Une exposition continue à des niveaux de pression acoustique supérieurs à 100 dB peut causer une perte d'acuité auditive permanente. Les systèmes audio de forte puissance pour auto peuvent produire des niveaux de pression acoustique bien au-delà de 130 dB. Faites preuve de bon sens et pratiquez une écoute sans risques.

PRACTIQUE EL SONIDO SEGURO

El contacto continuo con niveles de presión de sonido superiores a 100 dB puede causar la pérdida permanente de la audición. Los sistemas de sonido de alta potencia para automóviles pueden producir niveles de presión de sonido superiores a los 130 dB. Aplique el sentido común y practique el sonido seguro.

PRAKTIZIEREN SIE SICHEREN SOUND

Fortgesetzte Geräuschdruckpegel von über 100 dB können beim Menschen zu permanentem Hörverlust führen. Leistungsstarke Autosoundsysteme können Geräuschdruckpegel erzeugen, die weit über 130 dB liegen. Bitte wenden Sie gesunden Menschenverstand an und praktizieren Sie sicheren Sound.

OSSERVATE LE REGOLE DEL SUONO SENZA PERICOLI

La costante esposizione a livelli di pressione acustica al di sopra dei 100dB possono causare la perdita permanente dell'udito. I sistemi audio ad alta potenza possono produrre livelli di pressione acustica ben superiori ai 130dB. Si consiglia il buon senso e l'osservanza delle regole del suono senza pericoli.

Safety

This symbol with "WARNING" is intended to alert the user to the presence of important instructions. Failure to heed the instructions will result in severe injury or death.  **WARNING**

This symbol with "CAUTION" is intended to alert the user to the presence of important instructions. Failure to heed the instructions can result in injury or unit damage.  **CAUTION**

- To prevent injury and damage to the unit, please read and follow the instructions in this manual. We want you to enjoy this system, not get a headache.
- If you feel unsure about installing this system yourself, have it installed by a qualified Rockford Fosgate technician.
- Before installation, disconnect the battery negative (-) terminal to prevent damage to the unit, fire and/or possible injury.

Model	PM282W	PM282W-B	PM282HW	PM282HW-B
Nominal Diameter - inch (mm)	8 (203)	8 (203)	8 (203)	8 (203)
Description	2-Way	2-Way	2-Way	2-Way
Nominal Impedance (Ohms)	4Ω	4Ω	4Ω	4Ω
Frequency Response (Hz)	40-20kHz	40-20kHz	63-22kHz	63-22kHz
Voice Coil Diameter - inch (mm)	1.25 (32.3)	1.25 (32.3)	2 (50.8)	2 (50.8)
Power Handling - Watts (RMS/Peak)	100/200	100/200	150/300	150/300
Fs - Free Air Resonance (Hz)	50	50	84.5	84.5
Qts	0.57	0.57	0.58	0.58
Vas - cu. ft. (Liter)	1.06 (30)	1.06 (30)	0.39 (11)	0.39 (11)
Sensitivity (1W/1M)	90dB	90dB	93dB	93dB
Sensitivity (2.83V/1M)	93dB	93dB	96dB	96dB
Xmax - inch (mm)	0.28 (7)	0.28 (7)	0.04 (1)	0.04 (1)
Grille/Trim Ring	YES	YES	YES	YES



CEA 2031

Power handling on Rockford Fosgate speakers conform to CEA-2031 industry standards. This means your speaker has the capacity to handle power under continuous demand, not instantaneous power handling that over time can damage voice coils.



VERIFIED WITH KLIPPEL

To adorn the 'Verified with Klippel' mark, the qualifying company's loudspeaker engineering personnel must be trained and certified by Klippel prior to using the three separate Klippel systems to design, develop and test. Rockford Fosgate has made the investment in Klippel to deliver the best possible speakers and subwoofers to their customers.

PM282W/PM282W-B

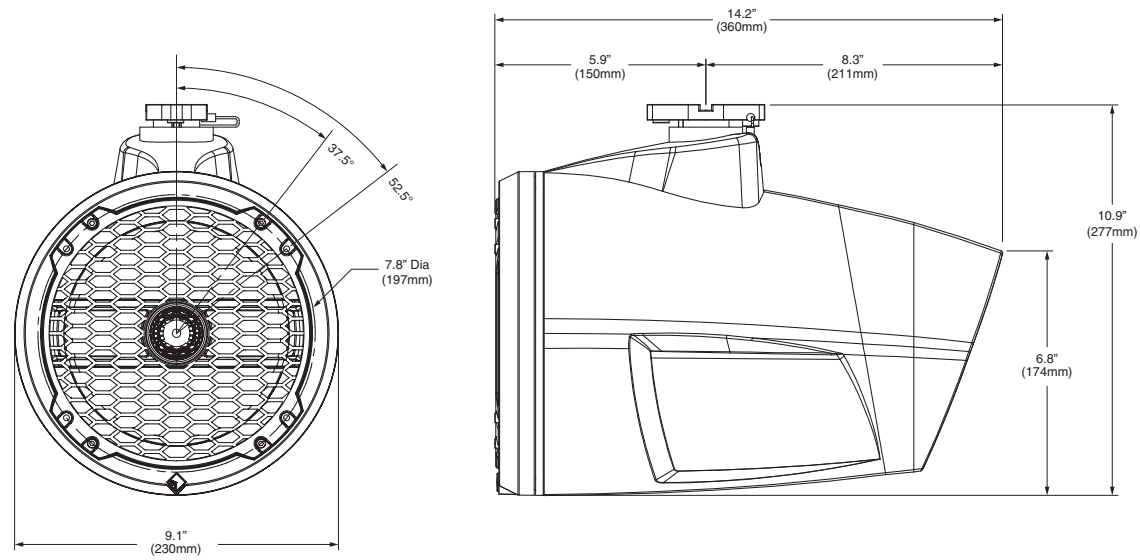

PM282HW/PM282HW-B

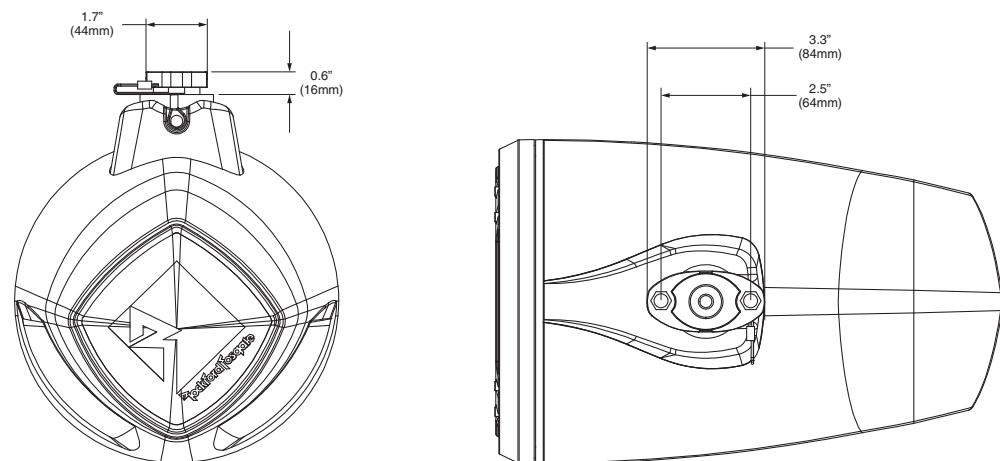
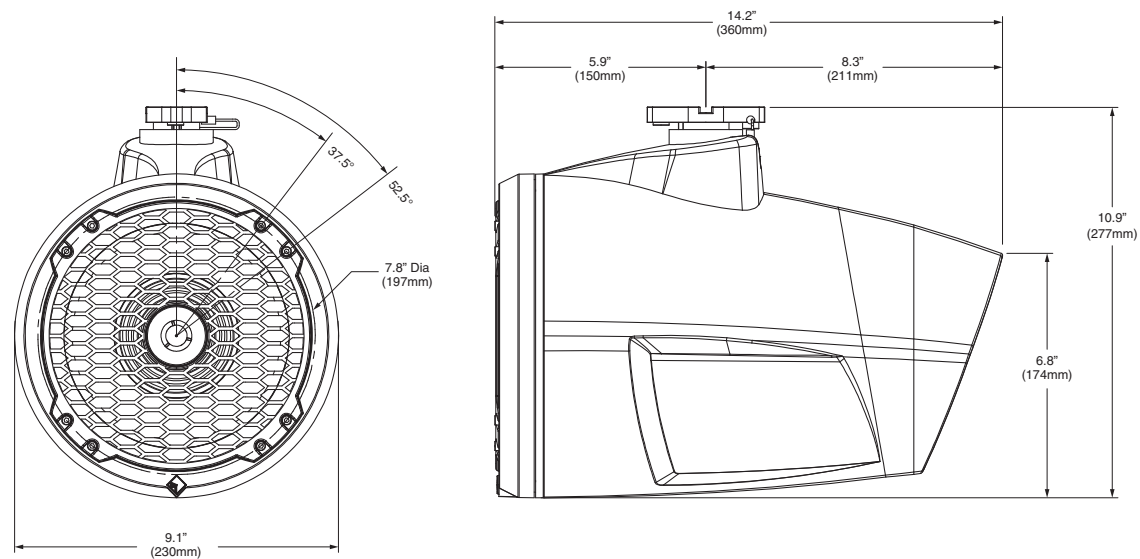

illus.-1.1

Contents

- (2) Marine Grade Speakers
- (2) Mounting Couplers
- (2) Molex Speaker Harnesses
- (2) Wire Grommets
- (1) Security Torx Wrench
- (2) Security Torx Bolts
- (4) Mounting Bolts
- (4) Mounting Bolt Nuts
- (2) Safety Lanyards
- (2) Layard Washers

Installation Considerations

Before beginning any installation, follow these simple rules:

1. Be sure to carefully read and understand the instructions before attempting to install these speakers.
2. For safety, disconnect the negative lead from the battery prior to beginning the installation.
3. For easier assembly, we suggest you run all wires prior to mounting your speakers in place.
4. Use high quality connectors for a reliable installation and to minimize signal or power loss.
5. Think before you drill! Be careful not to cut or drill into gas tanks, fuel lines, brake or hydraulic lines, vacuum lines or electrical wiring when working on any vehicle. If installation in a boat, take care not to cut or drill through the main hull.
6. Never run wires underneath the vehicle. Running the wires inside the vehicle or hull area provides the best protection.
7. Avoid running wires over or through sharp edges. Use rubber or plastic grommets to protect any wires routed through metal, especially the firewall.

Mounting

1. Determine where the speakers will be mounted. Be sure that the mounting location has sufficient clearance in all direction for the speaker to swivel; conduct a full rotation to ensure there is not obstruction.
2. Mark the locations on the underside of the mounting surface for the speaker mount and wire harness. Drill 5/16" holes for the mounting bolts and a 7/16" for the wire harness. If you want to surface mount the wiring, use the notch provided in the mount instead of drilling the hole.
3. Insert the supplied grommet and feed the wire harness through. Be sure to observe proper polarity when connecting the wires. The speaker harness's negative wire is indicated with a "black stripe".
4. Feed the speaker harness through the mount. Using the supplied hardware, through bolt and tighten the mount securing it. Be sure to connect the safety lanyard to the mount during this process.
5. Using the security torx bolt, slide the speaker enclosure onto the mount and tighten. Connect the other end of the safety lanyard to the security torx prior to tightening.
6. To swivel speaker, loosen security torx until speaker can swivel freely. Be sure to tighten once desired position is achieved.

Note: For tubular mounting applications, a Tower Speaker Clamp will be required. (PM-CL1/PM-CL1B)

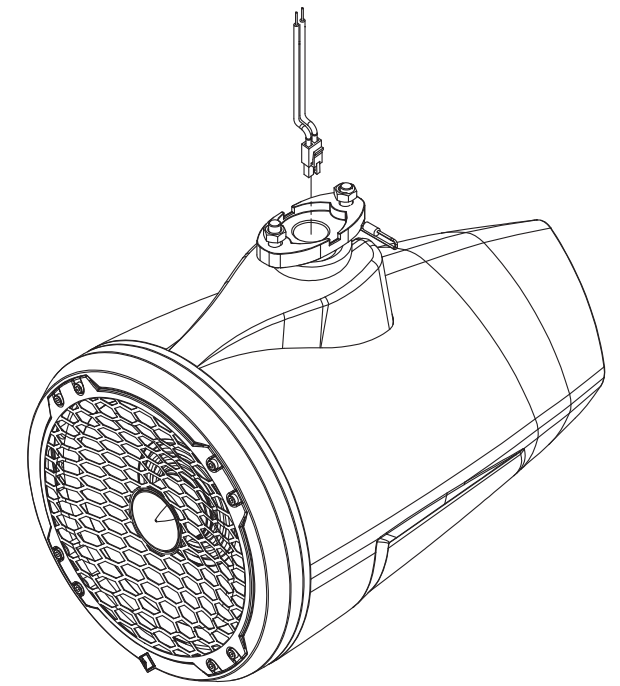

Typical Installation

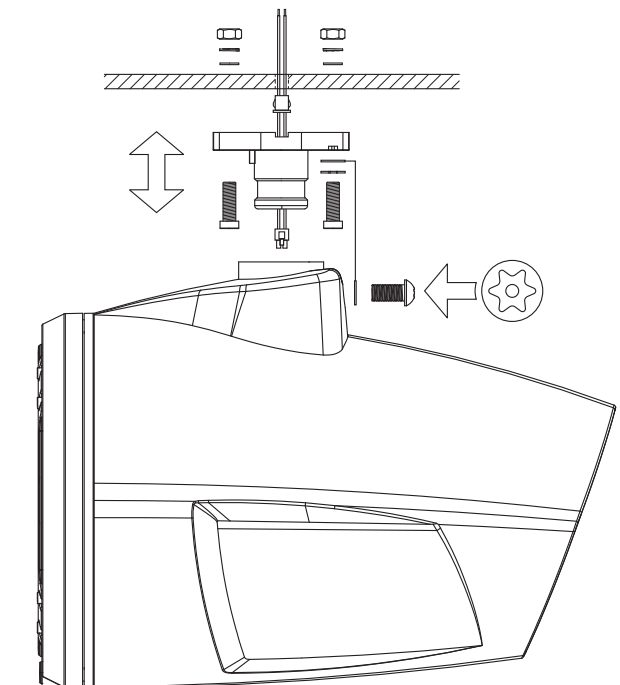

illus.-2.1

Considérations Concernant L'installation

Avant de commencer l'installation, suivez les règles ci-dessous:

1. Veillez à bien lire et comprendre les instructions avant d'essayer d'installer les haut-parleurs.
2. Par mesure de sécurité, débranchez le fil négatif de la batterie avant de commencer l'installation.
3. Pour faciliter le montage des haut-parleurs, il est conseillé d'installer tous les câbles au préalable.
4. Utilisez des connecteurs de haute qualité pour assurer une installation fiable et réduire au minimum la perte de signal ou de puissance.
5. Réfléchissez bien avant de percer. Veillez à ne pas couper ou percer le réservoir d'essence, le câblage électrique ou les conduites de carburant, de freinage hydraulique ou de dépression en travaillant sur un véhicule. En cas d'installation sur un bateau, veillez à ne pas couper ou percer la coque principale.
6. Ne jamais faire passer de fils sous le véhicule. Leur installation à l'intérieur du véhicule ou de la coque assure la meilleure protection.
7. Évitez de faire passer des fils sur des bords tranchants ou dans des orifices à arêtes vives. Utilisez des bagues en caoutchouc ou en plastique pour protéger les fils traversant une plaque de métal, notamment le tablier. Emplacements De Montage

Montage

1. Déterminer l'endroit de montage des haut-parleurs. S'assurer que l'emplacement de montage a suffisamment de dégagement dans tous les sens pour que le haut-parleur puisse pivoter; exécuter une rotation complète pour s'assurer qu'il n'y pas d'obstruction.
2. Marquer les emplacements sur le dessous de la surface de montage pour le support de haut-parleur et le faisceau électrique. Percer des trous de 5/16" pour les boulons de fixation et un trou de 7/16" pour le faisceau électrique. Pour monter le faisceau de fils en surface, utiliser l'encoche fournie dans le support au lieu de percer le trou.
3. Insérer le passe-câble fourni et y faire passer le faisceau électrique. S'assurer d'observer la polarité appropriée lors de la connexion des fils. Le fil négatif du faisceau électrique de haut-parleur est indiqué par une « rayure noire ».
4. Acheminer le faisceau électrique à travers le support. À l'aide de la visserie fournie, du boulon traversant et serrer le support pour le fixer. S'assurer de connecter la lanière de sécurité au support pendant ce processus.
5. À l'aide du boulon Torx de sécurité, faire glisser le boîtier de haut-parleur sur le support et serrer. Connecter l'autre extrémité de la lanière de sécurité au boulon Torx de sécurité avant de serrer.
6. Pour faire pivoter le haut-parleur, desserrer le boulon Torx de sécurité jusqu'à ce que le haut-parleur puisse pivoter librement. S'assurer de serrer une fois la position souhaitée obtenue.

Remarque : Pour les applications de fixation tubulaire, un collier de haut-parleur de tour sera requis. (PM-CL1/PM-CL1B)

Consideraciones para la instalación

Antes de comenzar cualquier instalación, siga estas simples normas:

1. Asegúrese de leer cuidadosamente y de entender las instrucciones antes de tratar de instalar estos altavoces.
2. Por seguridad, desconecte el conductor negativo de la batería antes de comenzar la instalación.
3. Para facilitar el montaje, sugerimos que tienda todos los cables antes de montar sus altavoces en su sitio.
4. Utilice conectores de alta calidad para tener una instalación confiable y para reducir al mínimo las pérdidas de señal o de potencia.
5. ¡Piense siempre antes de perforar! Tenga cuidado de no cortar ni perforar en tanques de combustible, tuberías de combustible, frenos o hidráulicas, tuberías de vacío o cableado eléctrico al trabajar en un vehículo. Si la instalación se hace en un bote, tenga cuidado de no cortar ni perforar a través del casco principal.
6. Nunca tienda cables abajo del vehículo. Tender los cables adentro del vehículo o casco proporciona la mejor protección.
7. Evite tender cables arriba o a través de bordes filosos. Use arandelas aislantes de caucho para proteger los cables tendidos a través de metal, especialmente la mampara cortafuegos. Montaje

Montaje

1. Determine dónde se montará los altavoces. Asegúrese de que la localidad de montaje tenga suficiente espacio libre en todas las direcciones para que el altavoz bascule; hágalo dar toda una vuelta para asegurarse de que no haya obstrucciones.
2. Marque las localidades en el lado inferior de la superficie de montaje para el soporte del altavoz y del arnés de cables. Perfore agujeros de 5/16 pulg. para los pernos de montaje y uno de 7/16 pulg. para el arnés de cables. Si desea montar el cableado en la superficie, use la muesca proporcionada en el soporte en vez de perforar el agujero.
3. Inserte las arandelas de caucho proporcionadas y pase el arnés de cable a través de las mismas. Asegúrese de usar la polaridad correcta al conectar los cables. Se ha identificado el cable negativo del arnés con una "franja negra".
4. Pase el arnés del altavoz a través del soporte. Usando el hardware proporcionado y el perno pasante, apriete el soporte asegurándolo. Asegúrese de conectar el cordón de seguridad al soporte durante este proceso.
5. Usando el perno torx de seguridad, deslice la caja del altavoz sobre el soporte y apriete. Conecte el otro extremo del cordón de seguridad al torx de seguridad antes de apretar.
6. Para hacer bascular el altavoz, suelte el torx de seguridad hasta que se pueda hacer bascular libremente el altavoz. Asegúrese de apretarlo una vez alcanzada la posición deseada.

Nota: Para las aplicaciones de montaje tubular, se requerirá una abrazadera para altavoz de torre. (PM-CL1/PM-CL1B)

Einbauüberlegungen

Befolgen Sie vor dem Einbau diese einfachen Regeln:

1. Lesen Sie die Anleitung sorgfältig, bevor Sie versuchen diese Lautsprecher einzubauen.
2. Entfernen Sie vor dem Einbau aus Sicherheitsgründen das negative Kabel von der Batterie.
3. Um die Montage zu erleichtern, empfehlen wir alle Kabel vor der Befestigung Ihrer Lautsprecher zu verlegen.
4. Verwenden Sie nur Qualitätsstecker, um einen zuverlässigen Einbau zu gewährleisten und Signal- und Stromverlust zu minimieren.
5. Denken Sie nach, bevor Sie bohren! Achten Sie darauf, nicht in den Benzintank, die Benzin-, Brems- oder hydraulischen Leitungen, Vakuuleitungen oder Elektrokabel zu schneiden oder zu bohren, wenn Sie am Fahrzeug arbeiten. Achten Sie beim Einbau in einem Boot darauf, nicht durch den Bootsrumpf zu schneiden oder zu bohren.
6. Verlegen Sie Kabel nie unter dem Fahrzeug. Die Kabel im Fahrzeug oder Bootsrumpf zu verlegen, bietet den besten Schutz.
7. Vermeiden Sie es, Kabel über scharfe Kanten zu verlegen. Verwenden Sie Gummi- oder Plastikringe, um Kabel zu schützen, die durch Metall verlegt werden (besonders die Feuerwand).

Befestigung

1. Entscheiden Sie wo die Lautsprecher montiert werden sollen. Prüfen Sie, dass die Stelle auf allen Seiten genug Freiraum hat, damit der Lautsprecher in alle Richtungen gedreht werden kann; drehen Sie ihn einmal um die ganze Achse um sicherzustellen, dass er nicht blockiert wird.
2. Markieren Sie die Stelle auf der Unterseite der Montagefläche für die Lautsprecherhalterung und den Kabelbaum. Bohren Sie 5/16 Zoll (0,8 cm) Löcher für die Befestigungsschrauben und ein 7/16 Zoll (1,1 cm) Loch für den Kabelbaum. Wenn Sie den Kabelsatz auf der Oberfläche anbringen möchten, benutzen Sie die bereits bestehende Kerbe anstatt ein Loch zu bohren.
3. Drücken Sie die beiliegende Tülle in das Loch und schieben Sie den Kabelbaum hindurch. Beim Anschließen der Drähte die richtige Polarität beachten! Das Minuskabel des Lautsprecher-Kabelsatzes ist durch einen "schwarzen Streifen" gekennzeichnet.
4. Schieben Sie den Kabelsatz des Lautsprechers durch die Montagefläche. Benutzen Sie die beiliegenden Befestigungsteilen und schieben Sie die Schraube durch und befestigen Sie sie auf der anderen Seite der Montagefläche. Prüfen Sie, dass das Sicherungskabel bei diesem Schritt auch auf der Montagefläche befestigt wird.
5. Mithilfe der Sicherheits-Torx-Schraube schieben Sie das Lautsprechergehäuse auf die Montagefläche und befestigen Sie es. Verbinden Sie das andere Ende des Sicherungskabels mit der Sicherheits-Torx-Schraube und ziehen Sie sie fest.
6. Um den Lautsprecher zu schwenken, lösen Sie die Sicherheits-Torx-Schraube bis der Lautsprecher sich frei drehen lässt. Nachdem Sie die gewünschte Position gefunden haben, ziehen Sie die Schraube wieder fest.

Hinweis: Für Rohrsysteme ist eine Lautsprecher-Klemmschraube erforderlich. (PM-CL1/PM-CL1B)

Considerazioni sull'installazione

Prima di iniziare qualsiasi operazione d'installazione, vi consigliamo di seguire queste semplici regole:

1. Assicuratevi di aver letto tutte le istruzioni con cura e di averle capite prima di effettuare qualsiasi tentativo d'installazione neiconfronti dell'unità.
2. Per motivi di sicurezza, scollegate il cavo negativo dalla batteria prima di dare l'avvio all'installazione.
3. Per facilitare il montaggio, vi suggeriamo di far scorrere tutti i fili prima di montare la vostra unità nella sua ubicazione.
4. Usate connettori di alta qualità per garantire un'installazione che dà affidamento e per ridurre al minimo la perdita di segnali o di potenza.
5. State attenti prima di trapanare! Cercate di non trapanare e di non incidere i serbatoi della benzina; le condutture del carburante, dei freni, del sistema idraulico e a depressione; nonché i fili elettrici quando state lavorando su qualsiasi veicolo.
6. Non fate mai scorrere i fili sotto il veicolo. Avrete la protezione migliore facendo scorrere i fili all'interno del veicolo.
7. Evitate di far scorrere i fili sopra o attraverso delle estremità affilate. Usate guarnizioni di tenuta in gomma o in plastica per proteggere qualsiasi filo che passi attraverso del metallo, soprattutto il parafiamma.

Montaggio

1. Stabilire dove verranno montati i diffusori. Accertarsi che la posizione di montaggio prescelta abbia spazio sufficiente in tutte le direzioni per poter ruotare il diffusore; effettuare una rotazione completa per accertarsi che non vi sia alcuna ostruzione.
2. Contrassegnare le posizioni sul lato inferiore della superficie di montaggio per la base del diffusore e il cablaggio di collegamento. Trapanare dei fori da 0,8 cm per i bulloni di montaggio e da 1,1 cm per il cablaggio di collegamento. Per il montaggio su superficie del cablaggio usare l'incisione che si trova nel supporto invece di trapanare un foro.
3. Inserire l'anello accluso e condurre il cablaggio di collegamento. Accertarsi di rispettare la polarità corretta quando si collegano i cavi. Il filo negativo del cablaggio del diffusore è indicato con una "striscia nera".
4. Condurre il cablaggio del diffusore attraverso il montaggio. Con la bulloneria acclusa e la vite passante avvitare il montaggio e serrarlo. Accertarsi di collegare il cordino di sicurezza al montaggio in questo passo.
5. Utilizzando la vite di sicurezza Torx infilare la cassa del diffusore sul montaggio e serrarla. Collegare l'altra fine del cordino di sicurezza alla vite di sicurezza Torx prima di serrarla.
6. Per ruotare il diffusore, allentare la vite di sicurezza Torx fino a quando il diffusore può ruotare liberamente. Accertarsi di serrarla nella posizione desiderata.

Nota: Per applicazioni di montaggio tubolare è necessario un morsetto per diffusori Tower. (PM-CL1/PM-CL1B)

Rockford Corporation offers a limited warranty on Rockford Fosgate products on the following terms:

Length of Warranty

POWER Amplifiers – 2 Years
BMW® Direct Fit Speakers – 2 Years
All other products – 1 Year
Any Factory Refurbished Product – 90 days (receipt required)

What is Covered

This warranty applies only to Rockford Fosgate products sold to consumers by Authorized Rockford Fosgate Dealers in the United States of America or its possessions. Product purchased by consumers from an Authorized Rockford Fosgate Dealer in another country are covered only by that country's Distributor and not by Rockford Corporation.

Who is Covered

This warranty covers only the original purchaser of Rockford product purchased from an Authorized Rockford Fosgate Dealer in the United States. In order to receive service, the purchaser must provide Rockford with a copy of the receipt stating the customer name, dealer name, product purchased and date of purchase.

Products found to be defective during the warranty period will be repaired or replaced (with a product deemed to be equivalent) at Rockford's discretion.

What is Not Covered

1. Damage caused by accident, abuse, improper operations, water, theft, shipping.
2. Any cost or expense related to the removal or reinstallation of product.
3. Service performed by anyone other than Rockford or an Authorized Rockford Fosgate Service Center.
4. Any product which has had the serial number defaced, altered, or removed.
5. Subsequent damage to other components.
6. Any product purchased outside the U.S.
7. Any product not purchased from an Authorized Rockford Fosgate Dealer.

Limit on Implied Warranties

Any implied warranties including warranties of fitness for use and merchantability are limited in duration to the period of the express warranty set forth above. Some states do not allow limitations on the length of an implied warranty, so this limitation may not apply. No person is authorized to assume for Rockford Fosgate any other liability in connection with the sale of the product.

How to Obtain Service

Contact the Authorized Rockford Fosgate Dealer you purchased this product from. If you need further assistance, call 1-800-669-9899 for Rockford Customer Service. You must obtain an RA# (Return Authorization number) to return any product to Rockford Fosgate. You are responsible for shipment of product to Rockford.

EU Warranty

This product meets the current EU warranty requirements, see your Authorized dealer for details.