

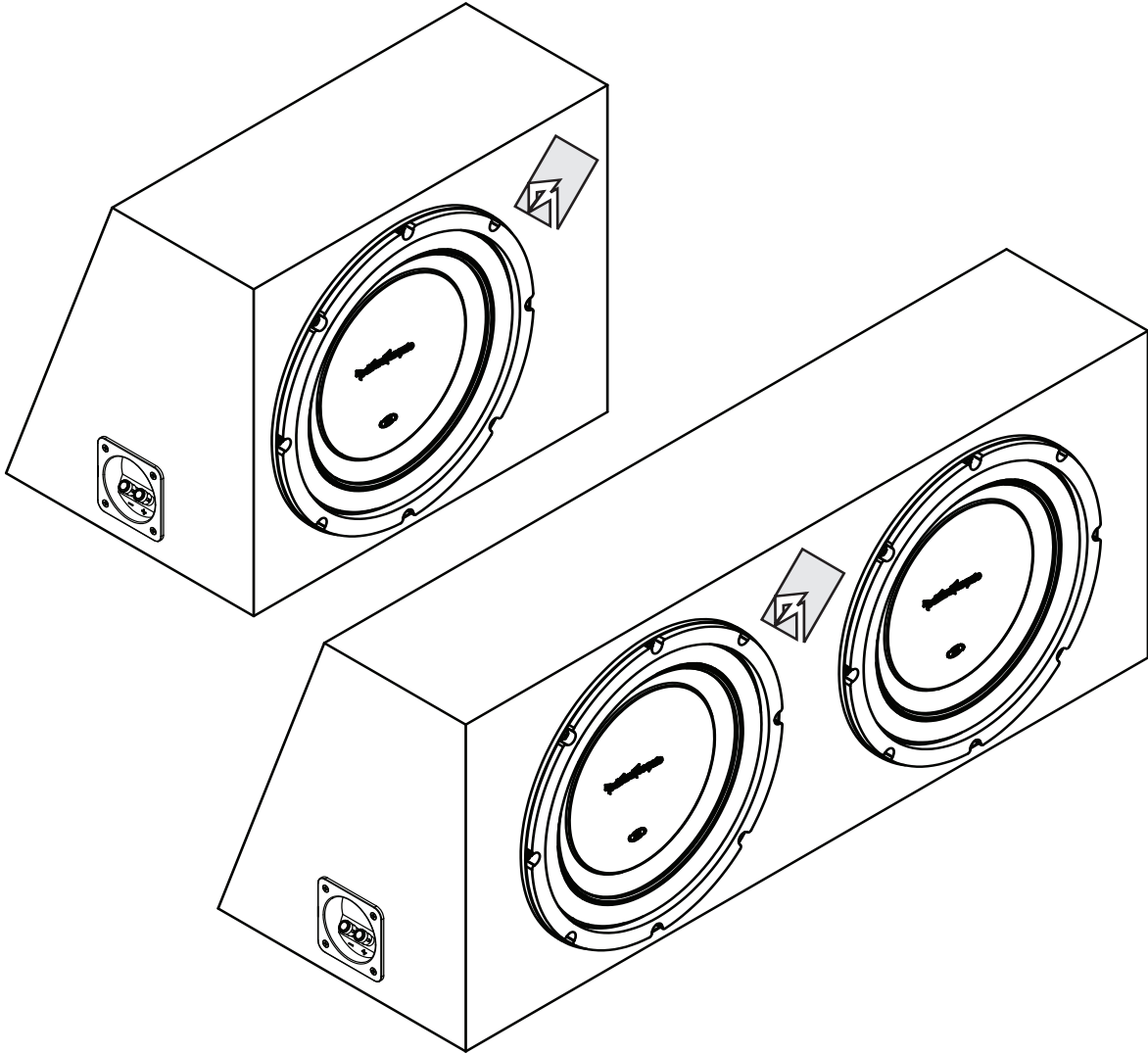

# Rockford Fosgate®



## PRIME™

### R1L – LOADED ENCLOSURES

---

#### SVC - SINGLE VOICE COIL SUBWOOFERS

	<b>10"</b>	<b>12"</b>
Single	R1L-1X10	R1L-1X12
Dual	R1L-2X10	R1L-2X12

---

#### Installation & Operation

Serial Number: \_\_\_\_\_

Date of Purchase: \_\_\_\_\_

# INSTALLATION – ENGLISH

**⚠ CAUTION:** Before installation, disconnect the battery negative (-) terminal to prevent damage to the unit, fire and/or possible injury.  
**Run the speaker cable from the amp.** When routing the speaker cable from the amplifier, avoid running it close to any sources of high current (wiring harnesses). The positive (+) speaker output from the amp connects to the red terminal of the enclosure, and the negative (-) connects to the black terminal.

# INSTALLATION – FRANÇAIS

**⚠ MISE EN GARDE :** avant d'entamer l'installation, déconnectez la broche négative (-) de la batterie pour éviter tout risque de blessures, d'incendie ou de dommages à l'appareil.

**Branchement du câble du haut-parleur de l'amplificateur.** En plaçant le câble du haut-parleur de l'ampli, évitez de l'approcher d'une source de courant important. La sortie positive de l'ampli se branche sur le terminal rouge du caisson, et le négatif se branche sur le terminal noir.

# INSTALACIÓN – ESPAÑOL

**⚠ PRECAUCIÓN:** Antes de la instalación, desconecte el terminal negativo de la batería (-) para prevenir daño a la unidad, incendio y/o posibles lesiones.

**Recorrido del Cable de Altavoz Desde el Amplificador.** Al llevar el cable de altavoz desde el amplificador, evite que pase cerca de cualquier fuente de alto corriente (cables de alimentación). El terminal positivo (+) de las salida de rojo, y el terminal negativo (-) al terminal negro.

# EINBAU – DEUTSCH

**⚠ VORSICHT:** Entfernen Sie vor dem Einbau den negative Batteriepol, um Schäden am Gerät, Feuer bzw. mögliche Verletzungen zu vermeiden.

**Anschluß des Lautsprecherkabels.** Beim Anschluß des Lautsprecherkabels sollten Sie darauf achten, daß das Kabel keine Fahrzeugstromkabel kreuzt, um Einstreuungen zu verhindern. Die Plus-Leitung des Lautsprecherkabels kommt in die rote Klemme des Terminals, die Negativ-Leitung in die schwarze Klemme des Terminals.

# INSTALLAZIONE – ITALIANO

**⚠ ATTENZIONE:** Prima dell'installazione, scollegate il terminale negativo (-) della batteria per evitare danni all'unità, pericoli d'incendio e/o potenziali lesioni personali.

**Far correre il cavo dell'altoparlante all'amplificatore.** Quando fate correre il cavo dell'altoparlante all'amplificatore non fatelo passare vicino a qualsiasi cavo dell'impianto elettrico di serie dell'auto. Il segnale positivo dell'altoparlante (+) in uscita dall'amplificatore á collegato al terminale rosso del diffusore, e il negativo (-) al terminale nero.

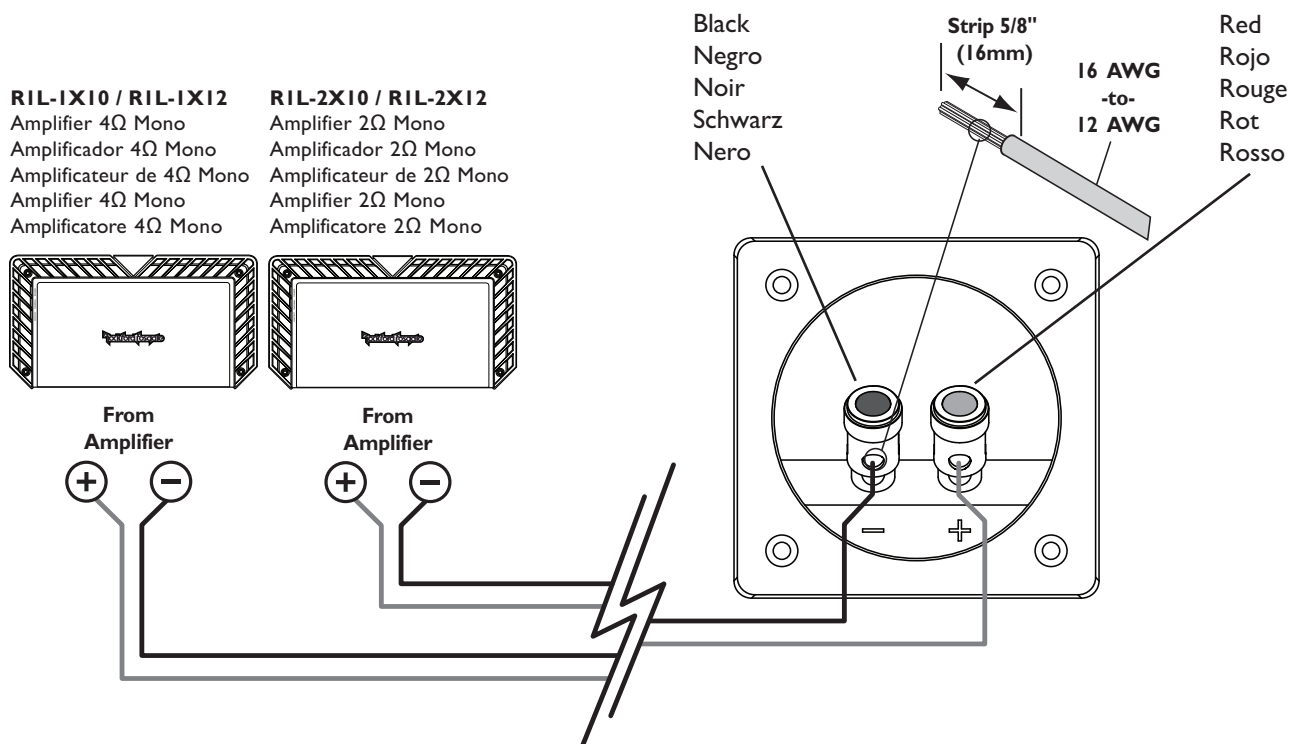

# FEATURES

---

## Enclosure Features

- High Current Binding Posts
- Constructed with 5/8" MDF
- Covered with High Density Carpet

## Speaker Features

- Parabolic polypropylene cone.
- 12 AWG compression terminals.
- 18 gauge stamped steel frame.
- Optimized for sealed enclosures.

# SPECIFICATIONS

---

## R1L-1X10

Nominal Impedance (Ohms)  
Replacement Woofer  
Power Handling (Watts)  
Overall Dimensions (HxWxD)

## Single 10" SVC

4  $\Omega$   
R1S410  
150 RMS / 300 Max  
12.0" x 15.825" x 12.25"  
(30.5cm x 40.1cm x 31.1cm)

## R1L-2X10

Nominal Impedance (Ohms)  
Replacement Woofer  
Power Handling (Watts)  
Overall Dimensions (HxWxD)

## Dual 10" SVC

2  $\Omega$   
R1S410 (wired internally)  
300 RMS / 600 Max  
12.0" x 30.0" x 12.25"  
(30.5cm x 76.2cm x 31.1cm)

## R1L-1X12

Nominal Impedance (Ohms)  
Replacement Woofer  
Power Handling (Watts)  
Overall Dimensions (HxWxD)

## Single 12" SVC

4  $\Omega$   
R1S412  
150 RMS / 300 Max  
14.0" x 17.5" x 12.25"  
(35.6cm x 44.5cm x 31.1cm)

## R1L-2X12

Nominal Impedance (Ohms)  
Replacement Woofer  
Power Handling (Watts)  
Overall Dimensions (HxWxD)

## Dual 12" SVC

2  $\Omega$   
R1S412 (wired internally)  
300 RMS / 600 Max  
14.0" x 33.75" x 12.25"  
(35.6cm x 85.7cm x 31.1cm)

Installation assistance available at:

# RFTECH

[www.rockfordfosgate.com/rftech](http://www.rockfordfosgate.com/rftech)

*Specifications subject to change without notice*

# LIMITED WARRANTY INFORMATION

---

Rockford Corporation offers a limited warranty on Rockford Fosgate products on the following terms:

## **Length of Warranty**

**Speakers – 1 Year. Any Factory Refurbished Product – 90 days (receipt required)**

## **What is Covered**

This warranty applies only to Rockford Fosgate products sold to consumers by Authorized Rockford Fosgate Dealers in the United States of America or its possessions. Product purchased by consumers from an Authorized Rockford Fosgate Dealer in another country are covered only by that country's Distributor and not by Rockford Corporation.

## **Who is Covered**

This warranty covers only the original purchaser of Rockford product purchased from an Authorized Rockford Fosgate Dealer in the United States. In order to receive service, the purchaser must provide Rockford with a copy of the receipt stating the customer name, dealer name, product purchased and date of purchase.

Products found to be defective during the warranty period will be repaired or replaced (with a product deemed to be equivalent) at Rockford's discretion.

## **What is Not Covered**

1. Damage caused by accident, abuse, improper operations, water, theft, shipping
2. Any cost or expense related to the removal or reinstallation of product
3. Service performed by anyone other than Rockford or an Authorized Rockford Fosgate Service Center
4. Any product which has had the serial number defaced, altered, or removed
5. Subsequent damage to other components
6. Any product purchased outside the U.S.
7. Any product not purchased from an Authorized Rockford Fosgate Dealer

## **Limit on Implied Warranties**

Any implied warranties including warranties of fitness for use and merchantability are limited in duration to the period of the express warranty set forth above. Some states do not allow limitations on the length of an implied warranty, so this limitation may not apply. No person is authorized to assume for Rockford Fosgate any other liability in connection with the sale of the product.

## **How to Obtain Service**

Contact the Authorized Rockford Fosgate Dealer you purchased this product from.

If you need further assistance, call 1-800-669-9899 for Rockford Customer Service. You must obtain an RA# (Return Authorization number) to return any product to Rockford Fosgate. You are responsible for shipment of product to Rockford.

## **EU Warranty**

This product meets the current EU warranty requirements, see your Authorized dealer for details.



**Rockford Fosgate**  
Rockford Corporation  
600 South Rockford Drive  
Tempe, Arizona 85281 U.S.A.  
In U.S.A., (480) 967-3565 - Customer Service 1-800-669-9899

[www.rockfordfosgate.com](http://www.rockfordfosgate.com)

