

# PUNCH™

## P1L & P2L - LOADED ENCLOSURES

### SVC - SINGLE VOICE COIL SUBWOOFERS

P1L	10"	12"
Single	P1L-110	P1L-112
Dual	P1L-210	P1L-212

### DVC - DUAL VOICE COIL SUBWOOFERS

P2L	10"	12"
Single	P2L-110	P2L-112
Dual	P2L-210	P2L-212

### Installation & Operation

Serial Number: \_\_\_\_\_

Date of Purchase: \_\_\_\_\_

# INSTALLATION – ENGLISH

**⚠ CAUTION:** Before installation, disconnect the battery negative (-) terminal to prevent damage to the unit, fire and/or possible injury.  
**Run the speaker cable from the amp.** When routing the speaker cable from the amplifier, avoid running it close to any sources of high current (wiring harnesses). The positive (+) speaker output from the amp connects to the red terminal of the enclosure, and the negative (-) connects to the black terminal.

# INSTALLATION – FRANÇAIS

**⚠ MISE EN GARDE :** avant d'entamer l'installation, déconnectez la broche négative (-) de la batterie pour éviter tout risque de blessures, d'incendie ou de dommages à l'appareil.

**Branchement du câble du haut-parleur de l'amplificateur.** En plaçant le câble du haut-parleur de l'ampli, évitez de l'approcher d'une source de courant important. La sortie positive de l'ampli se branche sur le terminal rouge du caisson, et le négatif se branche sur le terminal noir.

# INSTALACIÓN – ESPAÑOL

**⚠ PRECAUCIÓN:** Antes de la instalación, desconecte el terminal negativo de la batería (-) para prevenir daño a la unidad, incendio y/o posibles lesiones.

**Recorrido del Cable de Altavoz Desde el Amplificador.** Al llevar el cable de altavoz desde el amplificador, evite que pase cerca de cualquier fuente de alto corriente (cables de alimentación). El terminal positivo (+) de las salida de rojo, y el terminal negativo (-) al terminal negro.

# EINBAU – DEUTSCH

**⚠ VORSICHT:** Entfernen Sie vor dem Einbau den negative Batteriepol, um Schäden am Gerät, Feuer bzw. mögliche Verletzungen zu vermeiden.

**Anschluß des Lautsprecherkabels.** Beim Anschluß des Lautsprecherkabels sollten Sie darauf achten, daß das Kabel keine Fahrzeugstromkabel kreuzt, um Einstreuungen zu verhindern. Die Plus-Leitung des Lautsprecherkabels kommt in die rote Klemme des Terminals, die Negativ-Leitung in die schwarze Klemme des Terminals.

# INSTALLAZIONE – ITALIANO

**⚠ ATTENZIONE:** Prima dell'installazione, scollegate il terminale negativo (-) della batteria per evitare danni all'unità, pericoli d'incendio e/o potenziali lesioni personali.

**Far correre il cavo dell'altoparlante all'amplificatore.** Quando fate correre il cavo dell'altoparlante all'amplificatore non fatelo passare vicino a qualsiasi cavo dell'impianto elettrico di serie dell'auto. Il segnale positivo dell'altoparlante (+) in uscita dall'amplificatore è collegato al terminale rosso del diffusore, e il negativo (-) al terminale nero.

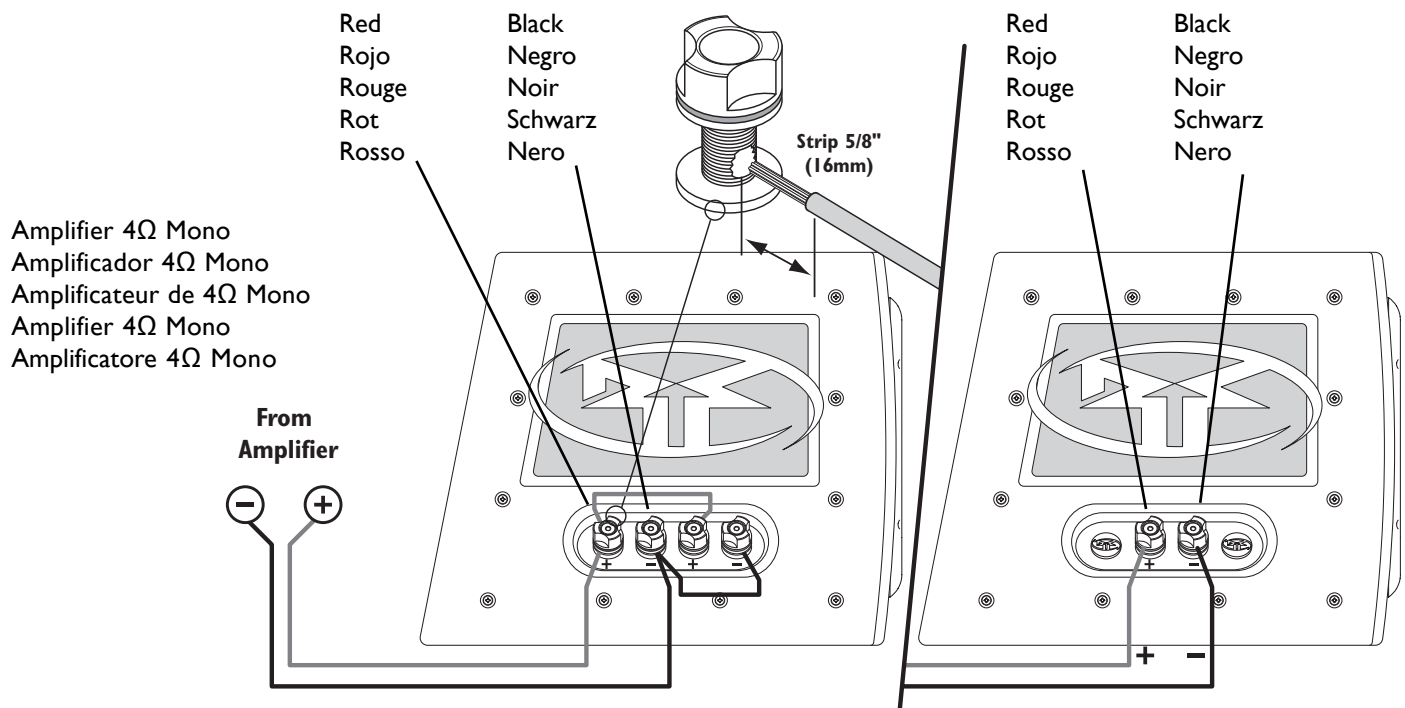

## Vented Enclosure Features

- Proprietary High-Flow, Low-Noise Ports
- High Current Binding Posts
- Constructed with 5/8" MDF
- Covered with High Density Carpet
- Wired Exclusively with Connecting Punch

## Speaker Features - P1L - SVC (Single Voice Coil)

- High modulus closed conical polypropylene cone.
- Tear & fatigue resistant poly-cotton spider.
- High density compressed half-roll sealed poly-foam surround.
- High temp voice coil with spun-laced Nomex™ insulating re-inforcement collar.
- Optimized motor magnetics with extended pole and bumped backplate.
- Sturdy 16 guage compound bend frame geometry.
- Proprietary spider venting/cooling technique.

## Speaker Features - P2L - DVC (Dual Voice Coil)

- Venturi-effect center pole dispersion venting/cooling system.
- High modulus closed conical polypropylene cone.
- Tear & fatigue resistant poly-cotton spider.
- High density compressed half-roll sealed poly-foam surround.
- High temp voice coil with spun-laced Nomex™ insulating re-inforcement collar.
- Optimized motor magnetics with extended pole and bumped backplate.
- Double stack ferrite magnet structure.
- Sturdy 16 guage compound bend frame geometry.
- Proprietary spider venting/cooling technique.
- Diamond cut cast aluminum motor cover for improved heat dissipation.

# SPECIFICATIONS

## P1L-110 (Single 10" SVC)

Nominal Impedance (Ohms)	4
Power Handling (Watts-RMS/Peak)	150 / 300
Internal Box Volume (ft <sup>3</sup> /liter)	1.05 (29.73L)
Overall Dimensions (HxWxD) (cm)	13.5" x 17.25" x 16" (34.3 x 43.8 x 40.6)

## P1L-210 (Dual 10" SVC)

Nominal Impedance (Ohms)	4 (8x2)
Power Handling (Watts-RMS/Peak)	300 / 600
Internal Box Volume (ft <sup>3</sup> /liter)	2.10 (59.46L)
Overall Dimensions (HxWxD) (cm)	13.5" x 31.25" x 16" (34.3 x 81.9 x 40.6)

## P1L-112 (Single 12" SVC)

Nominal Impedance (Ohms)	4
Power Handling (Watts-RMS/Peak)	150 / 300
Internal Box Volume (ft <sup>3</sup> /liter)	1.35 (38.23L)
Overall Dimensions (HxWxD) (cm)	15.5" x 19.25" x 16.5" (39.4 x 48.9 x 41.9)

## P1L-212 (Dual 12" SVC)

Nominal Impedance (Ohms)	4 (8x2)
Power Handling (Watts-RMS/Peak)	300 / 600
Internal Box Volume (ft <sup>3</sup> /liter)	2.70 (59.46L)
Overall Dimensions (HxWxD) (cm)	15.5" x 34" x 16.5" (39.4 x 86.4 x 41.9)

## P2L-110 (Single 10" DVC)

Nominal Impedance (Ohms)	4
Power Handling (Watts-RMS/Peak)	200 / 400
Internal Box Volume (ft <sup>3</sup> /liter)	1.05 (29.73L)
Overall Dimensions (HxWxD) (cm)	13.5" x 17.25" x 16" (34.3 x 43.8 x 40.6)

## P2L-210 (Dual 10" DVC)

Nominal Impedance (Ohms)	4 (8x2)
Power Handling (Watts-RMS/Peak)	400 / 800
Internal Box Volume (ft <sup>3</sup> /liter)	2.10 (59.46L)
Overall Dimensions (HxWxD) (cm)	13.5" x 31.25" x 16" (34.3 x 81.9 x 40.6)

## P2L-112 (Single 12" DVC)

Nominal Impedance (Ohms)	4
Power Handling (Watts-RMS/Peak)	200 / 400
Internal Box Volume (ft <sup>3</sup> /liter)	1.35 (38.23L)
Overall Dimensions (HxWxD) (cm)	15.5" x 19.25" x 16.5" (39.4 x 48.9 x 41.9)

## P2L-212 (Dual 12" DVC)

Nominal Impedance (Ohms)	4 (8x2)
Power Handling (Watts-RMS/Peak)	400 / 800
Internal Box Volume (ft <sup>3</sup> /liter)	2.70 (59.46L)
Overall Dimensions (HxWxD) (cm)	15.5" x 34" x 16.5" (39.4 x 86.4 x 41.9)

*Specifications subject to change without notice*

# **LIMITED WARRANTY INFORMATION**

---

Rockford Corporation offers a limited warranty on Rockford Fosgate products on the following terms:

## ***Length of Warranty***

**Speakers – 1 Year. Any Factory Refurbished Product – 90 days (receipt required)**

## ***What is Covered***

This warranty applies only to Rockford Fosgate products sold to consumers by Authorized Rockford Fosgate Dealers in the United States of America or its possessions. Product purchased by consumers from an Authorized Rockford Fosgate Dealer in another country are covered only by that country's Distributor and not by Rockford Corporation.

## ***Who is Covered***

This warranty covers only the original purchaser of Rockford product purchased from an Authorized Rockford Fosgate Dealer in the United States. In order to receive service, the purchaser must provide Rockford with a copy of the receipt stating the customer name, dealer name, product purchased and date of purchase.

Products found to be defective during the warranty period will be repaired or replaced (with a product deemed to be equivalent) at Rockford's discretion.

## ***What is Not Covered***

1. Damage caused by accident, abuse, improper operations, water, theft, shipping
2. Any cost or expense related to the removal or reinstallation of product
3. Service performed by anyone other than Rockford or an Authorized Rockford Fosgate Service Center
4. Any product which has had the serial number defaced, altered, or removed
5. Subsequent damage to other components
6. Any product purchased outside the U.S.
7. Any product not purchased from an Authorized Rockford Fosgate Dealer

## ***Limit on Implied Warranties***

Any implied warranties including warranties of fitness for use and merchantability are limited in duration to the period of the express warranty set forth above. Some states do not allow limitations on the length of an implied warranty, so this limitation may not apply. No person is authorized to assume for Rockford Fosgate any other liability in connection with the sale of the product.

## ***How to Obtain Service***

Contact the Authorized Rockford Fosgate Dealer you purchased this product from.

If you need further assistance, call 1-800-669-9899 for Rockford Customer Service. You must obtain an RA# (Return Authorization number) to return any product to Rockford Fosgate. You are responsible for shipment of product to Rockford.

## ***EU Warranty***

This product meets the current EU warranty requirements, see your Authorized dealer for details.



### **Rockford Fosgate**

Rockford Corporation  
546 South Rockford Drive  
Tempe, Arizona 85281 U.S.A.

In U.S.A., (480) 967-3565 - Customer Service 1-800-669-9899

In Europe, Fax (49) 850-3934-014

In Japan, Fax (81) 559-79-1265

[www.rockfordfosgate.com](http://www.rockfordfosgate.com)

©2006 Rockford Corporation. All rights reserved.

Rockford Fosgate, the Rockford Fosgate logo, and the PUNCH logo are either registered trademarks or trademarks of Rockford Corporation.