

Model: P2D28

Type: DVC Subwoofer

Power Rating: 200 Watts

Impedance: (2) x 2 ohms

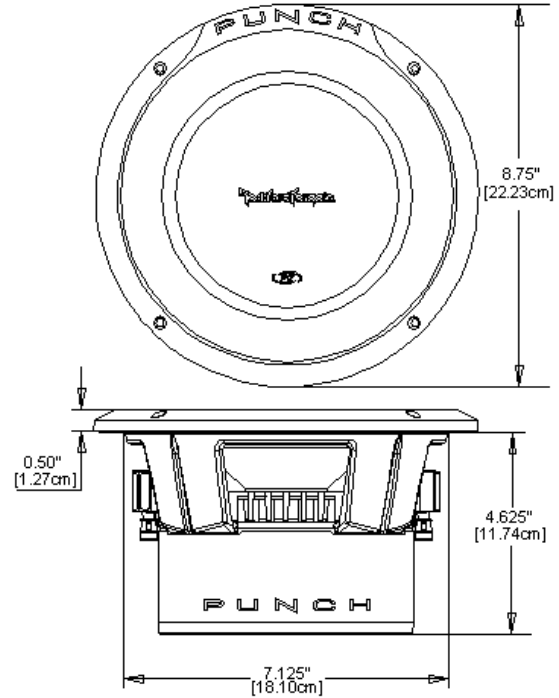

Features

- High modulus closed conical cone and ABS/Acrylic dustcap assembly.
- Mineral-filled polypropylene thermo-formed cone.
- Tear & fatigue resistant poly-cotton spider.
- High density compressed half-roll sealed poly-foam surround.
- High temp voice coil with spun-laced Nomex™ insulating reinforcement collar.
- Optimized motor magnetics with extended pole and bumped backplate.
- Fatigue resistant and reduced strain "stitched on" flexible lead wire design.
- Multi-point high-temp/high-strength neck joint bonding technique.
- Rigid compound bend 16 gauge cold-rolled stamped steel frame.
- Custom insulated/isolated compression input terminal assembly.
- Proprietary "Venturi effect" venting/cooling technique.
- Diamond-cut cast aluminum motor cover for improved heat dissipation.

Recommended Applications

Enclosure	Volume (Vb)		Tuning(Fb)	System (Qt)	-3dB (F3) Hz	Port Dia.		Port Length	
	Liters	cu.ft.	Hz			in.	mm	in.	mm
Sealed:	6.5	0.23	67.3	0.69	67.3	-	-	-	-
Ported:	18.4	0.65	38.5	-	33.3	2.0	50.8	8.0	203.2

Thiele-Small Specifications

- Fs (Hz): 40.0
- Re (Ohms): 3.50
- Le (mH): 2.5
- Qts: 0.45
- Qes: 0.48
- Qms: 6.00
- Cms (m/N): 0.18
- Vas (L): 10.0
- Mms (g): 88.5
- Mmd (g): 86.9
- Rms (kg/s): 3.7
- Airload (g): 1.6
- No (%): 0.16
- SPL (dB - 1W/1M): 84.0
- BL (T*M): 13.0
- *Xmax₁₀ (mm): 9.5
- Sd (cm²): 200
- EBP: 83
- Krm (mOhms): 0.76
- Erm: 1.17
- Kxm (mH): 84.9
- Exm: 0.61
- Rem (Ohms): 21.12

SPL (at 200 Watts) / Impedance (at 1 Watt)

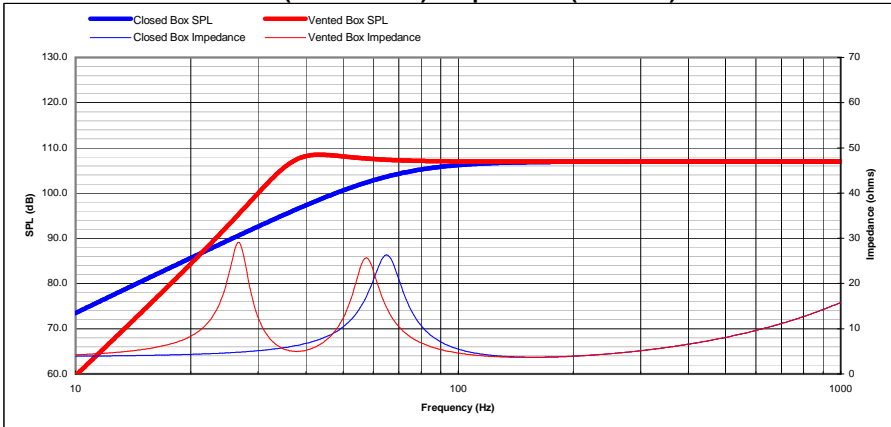

Technical Specifications

Voice Coil Diameter:	2	50.8	inches mm
Voice Coil Height:	1.02	25.9	inches mm
Voice Coil Layers:	4		layers
Magnetic Gap Height:	0.394	10.0	inches mm
Linear Excursion, pk-pk (Xmax):	0.315	8.0	inches mm
Maximum Excursion, pk-pk:	1.57	39.9	inches mm
Magnet Weight:	38	1.08	oz. kg
Woofer Displacement:	0.85	0.030	liters cubic ft.
Net Weight:	8.1	3.7	lbs. kg
Power Rating:	200	400	RMS Peak

* All parameters are derived using a laser velocity measurement method and verified with actual measured Mmd and Re. All dual voice coil models are wired in series. Xmax₁₀ represents actual effective excursion at <10% THD.