

Rockford Fosgate®

**CPCC15
CPCC25
CPCC40**

**Installation &
Operation**



CARBON CAPACITOR

15 Farad,

25 Farad or

40 Farad

16 Volt Carbon Capacitor

INTRODUCTION

Thank you for purchasing the Rockford Fosgate Carbon Capacitor. The Rockford Carbon Capacitors, also known as Electric Double Layer Capacitors (EDLC) or Super Capacitors, are passive electrostatic energy storage devices. They are state of the art technology that allows you to put massive power storage in a very small space

What are Rockford Carbon Capacitors good for?

Some of the most promising applications that have been found for Rockford Carbon Capacitors are battery and large audio system performance enhancement. Even the very best batteries, that present day technology has to offer, have performance limitations determined by the laws of physics and chemistry that govern their operation. Rockford Carbon Capacitors supply their energy much faster than a battery. A properly installed Rockford Carbon Capacitor can deliver the instantaneous power (Amps) that are commonly demanded by today's large audio systems.

How do Rockford Carbon Capacitors compare with Batteries?

Rockford Carbon Capacitors have approximately 10 times the power density of a same sized battery and the capability of being charged and discharged over 100 times faster than a battery. This is why they make such great intermediate power sources. However, Rockford Carbon Capacitors do not have the characteristic battery limitations of a short life span, cold intolerance, and critical charge and discharge rates.

What makes Rockford Carbon Capacitor Cells so special?

The electrode forming process, which produces ultra-dense yet porous carbon electrodes, and the continuous operating voltage of 2.7 volts (per cell) give the Rockford Carbon Capacitor the highest energy storage capacity and power density of any other commercially available components of comparable size and weight.

To add the finishing touch to your new Rockford Fosgate system order your Punch Sport apparel, which include everything from T-shirts and jackets to hats and sunglasses.

To get a free brochure on Rockford Fosgate products and Punch Sport apparel, in the U.S. call 480-967-3565 or FAX 480-967-8132.

For all other countries, call +001-480-967-3565 or FAX +001-480-967-8132.

Or, visit our web site at **www.rockfordfosgate.com**

If, after reading your manual, you still have questions regarding this product, we recommend that you see your Rockford Fosgate dealer. If you need further assistance, you can call us direct at 1-800-669-9899. Be sure to have your model number and date of purchase available when you call. (Outside U.S. call 1-480-967-3565)

TABLE OF CONTENTS

Introduction	2	Installation	4-7
Safety Instructions	3	Installation Considerations	4
Contents of Carton	3	Mounting Locations	5
Design Features	4	Wiring the System	5
Safety Features	4	Specifications	8
		Limited Warranty Information	9

NOTE: Review each section for more detailed information.

Visit our web site for the latest information on all Rockford products.

www.rockfordfosgate.com

WARNING

This symbol with “**WARNING**” is intended to alert the user to the presence of important instructions. Failure to heed the instructions will result in severe injury or death.

CAUTION

This symbol with “**CAUTION**” is intended to alert the user to the presence of important instructions. Failure to heed the instructions can result in injury or unit damage.

 **CAUTION:** To prevent injury and damage to the unit, please read and follow the instructions in this manual. We want you to have enjoyment from this system, not a headache.

 **CAUTION:** If you feel unsure about installing this system yourself, have it installed by a qualified Rockford Fosgate technician.

 **CAUTION:** Before installation, disconnect the battery negative (-) and positive (+) terminal to prevent damage to the unit, fire and/or possible injury.

 **WARNING:** To prevent serious personal injury, fire and/or damage, ensure the capacitor has been properly discharged before servicing the vehicle and/or system components.

 **CAUTION:** Failure to observe the following safety precautions could result in damage to the capacitor, vehicle and/or personal injury.

- **DO NOT** allow metal objects, such as screwdrivers or other tools, to touch both capacitor terminals at the same time. The result may cause arcing and possible fire.
- **DO NOT** use capacitor cells that have signs of damage, including cracks, leaks, or swelling.
- **DO NOT** expose capacitor cells to flames, sparks or heat at any time.
- **DO NOT** immerse capacitor cells in water or allow water to come into contact with them at any time.
- **DO NOT** remove the electrolyte filling bolt from the top of a capacitor cell at any time.
- **DO NOT** connect the positive (+) wire from the battery to the negative (-) terminal of the capacitor.
- **DO NOT** connect the negative (-) wire from the battery to the positive (+) terminal of the capacitor.
- **DO NOT** make any connections to a capacitor if the connecting polarity cannot be properly identified. Applying reversed polarity will damage capacitor cells.

CONTENTS OF CARTON

Either a model CPCC15, CPCC25 or
CPCC40 Carbon Capacitor Module
Installation & Operation Manual

Charging Resistor
Warning Label

DESIGN FEATURES

The following features are the results of the unique patented manufacturing process that enables the Rockford Carbon Capacitor to deliver many charge and discharge cycles with greater energy and power per unit weight and volume.

High Energy

The amazingly high specific capacitance and lower weight of Rockford's Carbon Capacitor yields an energy per kilogram figure that is twice that of any other commercially available Electric Double Layer Capacitor (EDLC).

More Power

Both the 'per weight' and 'per volume' power density of Rockford's Carbon Capacitor exceeds that of other carbon capacitors in production today. The extremely low internal resistance (ESR) characteristic of Rockford's Carbon Capacitor enables them to supply large amounts of instantaneous peak power, when demanded by the load.

Long Life

Rockford's Carbon Capacitor has a very long life span as well. They have been subjected to more than 500,000 charge and discharge cycles and only show a small typical loss of capacitance (less than 20%) and an even smaller than typical increase in ESR (less than 2X). The long life span of the Rockford's Carbon Capacitor means that it may never need to be replaced.

Excellent Low Temperature Performance

Rockford's Carbon Capacitors show very little loss of effective capacitance or ESR, even at temperatures as low as -940F (-940C).

SAFETY FEATURES

LED Display

The display at the top of the Rockford Carbon Capacitor will show the current voltage at the capacitor.

Warning Buzzer

The warning buzzer will sound if the Rockford Carbon Capacitor has been wired to a reverse polarity.

Safety Vent

The safety vent ruptures when the internal pressure of capacitor cell has reached 5 ~ 10 kg/cm2.

 **CAUTION:** To prevent injury due to hazardous chemicals, do not touch the capacitor if the safety vent has ruptured. Have the system looked at by a qualified technician for repair and/or disposal.

ATTENTION: Safety vent ruptures caused by improper wiring is not covered under warranty.

INSTALLATION

INSTALLATION CONSIDERATIONS

The following is a list of tools needed for installation:

Volt/Ohm Meter	Battery post wrench
Wire strippers	Hand held drill w/assorted bits
Wire crimpers	Electrical tape
Wire cutters	Rubber or snap grommets
Felt-tip pen or center punch	Nylon tie straps
#2 Phillips screwdriver	Assorted connectors
3/16" Allen wrench	Adequate Length—Red Power Wire
5/32" Allen wrench	Adequate Length—Black Grounding Wire

This section focuses on some of the vehicle considerations for installing your new Rockford Fosgate Carbon Capacitor. Pre-planning your system layout and best wiring routes will save installation time. When deciding on the layout of your new system, be sure that each component will be easily accessible for making adjustments.

 **CAUTION:** If you feel unsure about installing this system yourself, have it installed by a qualified Rockford Fosgate technician.

 **CAUTION:** Before installation, disconnect the battery negative (-) and positive (+) terminals to prevent damage to the unit, fire and/or possible injury.

Before beginning any installation, follow these simple rules:

1. Be sure to carefully read and understand the instructions before attempting to install the unit.
2. For safety, disconnect the negative lead from the battery prior to beginning the installation.
3. For easier assembly, we suggest you run all wires prior to mounting your unit in place.
4. Route all of the high current wires close together and away from any RCA cables.
5. Use high quality connectors for a reliable installation and to minimize signal or power loss.
6. Think before you drill! Be careful not to cut or drill into gas tanks, fuel lines, brake or hydraulic lines, vacuum lines or electrical wiring when working on any vehicle.
7. Never run wires underneath the vehicle. Running the wires inside the vehicle provides the best protection.
8. Avoid running wires over or through sharp edges. Use rubber or plastic grommets to protect any wires routed through metal, especially the firewall.
9. ALWAYS protect the battery and electrical system from damage with proper fusing. Install the appropriate fuse holder and fuse on the +12V power wire within 18" (45.7 cm) of the battery terminal.
10. When grounding to the chassis of the vehicle, scrape all paint from the metal to ensure a good, clean ground connection. Grounding connections should be as short as possible and always be connected to metal that is welded to the main body, or chassis, of the vehicle.

MOUNTING LOCATIONS

Select a dry location that will provide good ventilation around the Rockford Carbon Capacitor (CPCC). We recommend that you mount the CPCC on the floor of the trunk or in a location where it will be protected from water damage.

- Mount in a location free from grease, water, flames, sparks or heat. Preferably in the trunk of the vehicle.
- The CPCC should be mounted with the supplied screws as close to the amplifier as possible keeping the wire runs short. It is recommended that runs be kept less than 24 inches, as this will help to reduce voltage loss in the cables.
- Mark the location where the CPCC is to be mounted. After wiring the system, mount the CPCC into place.

WIRING THE SYSTEM

 **CAUTION:** If you do not feel comfortable with wiring your new unit, please see your local Authorized Rockford Fosgate Dealer for installation.

 **CAUTION:** Before installation, disconnect the battery negative (-) and positive (+) terminals to prevent damage to the unit, fire and/or possible injury.

 **CAUTION:** Avoid running power wires near the low level input cables, antenna, power leads, sensitive equipment or harnesses. The power wires carry substantial current and could induce noise into the audio system.

 **CAUTION:** Improper wiring connections can seriously damage the CPCC and/or your vehicle. Be sure to carefully follow the connection instructions in this manual. Improper wiring will void warranty.

INSTALLATION

ATTENTION: Make sure the battery and all other power sources are disconnected.

 **CAUTION:** Ensure correct polarity during the following connections. Failure to do so may cause damage to the unit when power is applied.

NOTE: If a reverse polarity has been connected to the CPCC, a warning buzzer will sound when power is applied. **Immediately** disconnect the CPCC from power, ensure it has been discharged and reconnected to correct polarity.

1. Attach the ground wire to the negative terminal block of the capacitor. The negative terminal is marked with a (-) Negative Connections. Attach the other end of the ground wire to the chassis of the car, ensure there is good metal to metal contact. Ensure that no stray wires are visible. Ensure all wires are secured. Loose connections will affect the performance of your CPCC, possibly leading to failure.
2. Attach a fused Power wire to the positive terminal of the capacitor. The positive terminal is the platinum colored block marked with a (+) Positive Connections. Ensure that no stray wires are visible. Ensure all wires are secured. Loose connections will affect the performance of your CPCC, possibly leading to failure.
3. To hook up your amplifier or distribution block, use the available 2 AWG or 4 AWG connections.
4. Mount the unit securely in the location decided upon.

Charging and connecting the CPCC Carbon Capacitor to the battery

Overcharging cells will reduce their useful life span. HINT: Charging cells at an ambient temperature of less than +77°F (+25°C) will minimize the deterioration of their useful life span (keeping it near their 500,000 cycle expectation).

1. Make sure all power and ground connections are made at the capacitor module.
2. Reconnect the battery and any other power source that may have been disconnected.

NOTE: If a reverse polarity has been connected to the CPCC, a warning buzzer will sound when power is applied. **Immediately** disconnect the CPCC from power, ensure it has been discharged and reconnected to correct polarity.

3. Attach one end of the charging resistor to the power wire leading to the capacitor module. It is highly suggested that you place a fuse before the capacitor. This is to insure that if the capacitor were to be placed in reverse polarity it would blow the fuse first, not the cap.
4. Attach the other end of the charging resistor to the positive battery post.
5. The **red** Led will become dim and turn off after reaching battery voltage, usually 12.6 volts. This will take approximately 10 minutes. To achieve a more accurate reading, place the red lead of a voltmeter on the side of the charging resistor leading to the capacitor module (cap side of the fuse) and the black lead to chassis of the vehicle or to the negative battery clamp.
6. Once a full charge has been reached and the capacitor module reads the same voltage as the battery, connect the power wire leading to the capacitor module to the positive battery post. Attention, small sparks may occur.
7. At this point, it is very important to place the yellow warning label on the top of the battery or a highly visible location. This will let any persons know that an auxiliary form of power is hooked up. It is very very important that the capacitor module be discharged before performing any kind of service on the vehicle. It is important to remember that your Rockford Carbon Capacitor could still be fully charged and could cause personal injury if not discharged.
8. The Rockford Carbon Capacitor is now ready for use.

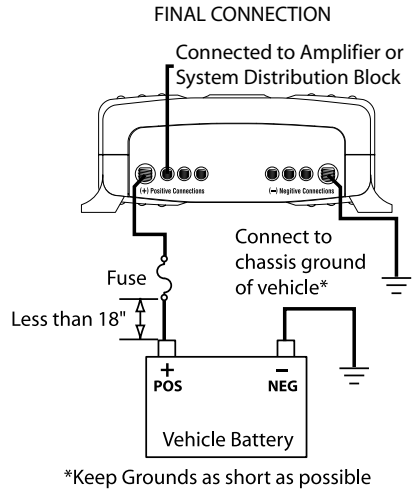
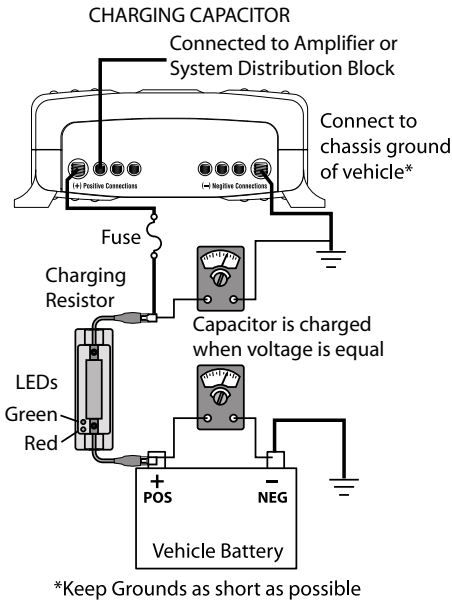

Discharging the CPCC Carbon Capacitor

WARNING: To prevent serious personal injury, fire and/or damage, ensure the capacitor has been properly discharged before servicing the vehicle and/or system components.

1. Disconnect the power wire going to the capacitor module from the battery.
2. Attach one end of the charging resistor to the power wire leading to the capacitor module. (Show charging resistor)
3. Attach the other end of the charging resistor to the chassis of the vehicle or to the negative battery clamp.
4. The **green** Led will become dim and turn off when discharging has been completed, approximately 10 minutes. Again to gain a more accurate reading, place the red lead of a voltmeter on the side of the charging resistor leading to the capacitor module (capacitor side of the fuse) and the black lead to chassis of the vehicle or to the negative battery clamp.

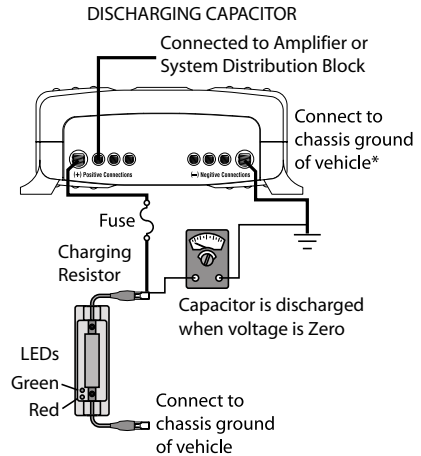

DISPOSING OF CARBON CAPACITOR CELLS

A Rockford Carbon Capacitor cell contains hazardous material, such as Acetonitrile (ACN). You must follow federal, state, and local laws when disposing of failed or aged cells. For more information, contact the Customer Support department of Rockford Corp. 1-800-669-9899. Capacitor modules that have reached their end-of-life can be recycled. Rockford Corp. will take back capacitor modules that need to be recycled. Rockford does not pay for shipping of returned capacitor modules that are to be recycled.

CAUTION: To prevent injury due to hazardous chemicals, do not touch the capacitor if the safety vent has ruptured. Have the system looked at by a qualified technician for repair and/or disposal.

SPECIFICATIONS

MODEL- Connecting Punch	CPCC15	CPCC25	CPCC40
Rated Capacitance – 77°F (25°C) (Constant Current Discharge (5A) 15.0v→3.0v)	15 Farads	25 Farads	40 Farads
Capacitance Tolerance	-10% / 30%	-10% / 30%	-10% / 30%
Rated Voltage, Vr	16.0 Volts	16.0 Volts	16.0 Volts
Surge Voltage	17.1 Volts	17.1 Volts	17.1 Volts
Rated Current – 77°F (25°C) (5 second discharge rate to 1/2Vr)	40 Amps	40 Amps	65 Amps
Maximum Current – 77°F (25°C)	154 Amps at 12.6V	250 Amps at 12.6V	400 Amps at 12.6V
Maximum Stored Energy (at Vr)	1940 Joules (0.5 Wh)	3200 Joules (0.9 Wh)	5120 Joules (1.4 Wh)
Maximum Internal Resistance (ESR):	<36mΩ	<18mΩ	<12mΩ
Operating Temperature Range*	-40 to 140°F (-40 to 60°C)	-40 to 140°F (-40 to 60°C)	-40 to 140°F (-40 to 60°C)
Storage Temperature Range	-40 to 158°F (-40 to 70°C)	-40 to 158°F (-40 to 70°C)	-40 to 158°F (-40 to 70°C)
Input/Output Connections (AWG-American Wire Gauge)	(1) 2 AWG, (3) 4 AWG	(1) 2 AWG, (3) 4 AWG	(1) 2 AWG, (3) 4 AWG
Dimensions:			
Height	3.15" (8.0cm)	3.15" (8.0cm)	3.15" (8.0cm)
Width	10.0" (25.4cm)	10.0" (25.4cm)	10.0" (25.4cm)
Length	7.56" (19.2cm)	7.56" (19.2cm)	7.56" (19.2cm)
Weight:	3.31 lbs. (1.5kg)	3.75 lbs. (1.7kg)	4.19 lbs. (1.9kg)

**Prolonged operation above the operating temperature limit of a cell will greatly reduce its useful life span. Exposure to temperatures below the operating temperature will reduce the ability of the cell to easily accept a charge.*

Specifications subject to change without notice

Rockford Corporation offers a limited warranty on Rockford Fosgate products on the following terms:

Length of Warranty

One (1) Year (Proof of purchase required)

**If installed by an Authorized Rockford Fosgate Dealer, two (2) years
(Proof of purchase required)**

What is Covered

This warranty applies only to Rockford Fosgate products sold to consumers by Authorized Rockford Fosgate Dealers in the United States of America or its possessions. Product purchased by consumers from an Authorized Rockford Fosgate Dealer in another country are covered only by that country's Distributor and not by Rockford Corporation.

Who is Covered

This warranty covers only the original purchaser of Rockford product purchased from an Authorized Rockford Fosgate Dealer in the United States. In order to receive service, the purchaser must provide Rockford with a copy of the receipt stating the customer name, dealer name, product purchased and date of purchase.

Products found to be defective during the warranty period will be repaired or replaced (with a product deemed to be equivalent) at Rockford's discretion.

What is Not Covered

1. Damage caused by accident, abuse, improper operations, improper wiring, water, theft.
2. Any cost or expense related to the removal or reinstallation of product.
3. Service performed by anyone other than Rockford or an Authorized Rockford Fosgate Service Center.
4. Any product which has had the serial number defaced, altered, or removed.
5. Subsequent damage to other components.
6. Any product purchased outside the U.S.
7. Any product not purchased from an Authorized Rockford Fosgate Dealer.
8. Broken or stripped screws.

Limit on Implied Warranties

Any implied warranties including warranties of fitness for use and merchantability are limited in duration to the period of the express warranty set forth above. Some states do not allow limitations on the length of an implied warranty, so this limitation may not apply. No person is authorized to assume for Rockford Fosgate any other liability in connection with the sale of the product.

How to Obtain Service

Please call 1-800-669-9899 for Rockford Customer Service. You must obtain an RA# (Return Authorization number) to return any product to Rockford Fosgate. You are responsible for shipment of product to Rockford.

EU Warranty

This product meets the current EU warranty requirements, see your Authorized dealer for details.

Ship to: **Electronics**
Rockford Corporation
Warranty Repair Department
2055 E. 5th Street
Tempe, AZ 85281
RA#: _____

Ship to: **Speakers**
Rockford Acoustic Design
Speaker Returns
2356 Turner Ave. NW
Grand Rapids, MI 49544
RA#: _____

Rockford Fosgate®

Installation assistance available at:

RFTECH

www.rockfordfosgate.com/rftech



Rockford Fosgate

Rockford Corporation
546 South Rockford Drive
Tempe, Arizona 85281 U.S.A.
In U.S.A., (480) 967-3565
In Europe, Fax (49) 8503-934014
In Japan, Fax (81) 559-79-1265

www.rockfordfosgate.com