

FNX1414
FNX1514
FNX1614F
FNX1614



fanatic X
component systems

fanatic



operation & installation

Dear Customer,

Congratulations on your purchase of the world's finest brand of car audio speakers. At Rockford Fosgate we are fanatics about musical reproduction at its best, and we are pleased you chose our product. Through years of engineering expertise, hand craftsmanship and critical testing procedures, we have created a wide range of products that reproduce music with all the clarity and richness you deserve.

For maximum performance we recommend you have your new Rockford Fosgate product installed by an Authorized Rockford Fosgate Dealer, as we provide specialized training through Rockford Technical Training Institute (RTTI). Please read your warranty and retain your receipt and original carton for possible future use.

Great product and competent installations are only a piece of the puzzle when it comes to your system. Make sure that your installer is using 100% authentic installation accessories from Connecting Punch in your installation. Connecting Punch has everything from RCA cables and speaker wire to Power line and battery connectors. Insist on it! After all, your new system deserves nothing but the best.

To add the finishing touch to your new Rockford Fosgate image order your Rockford wearables, which include everything from T-shirts and jackets to hats and sunglasses.

To get a free brochure on Rockford Fosgate products and Rockford accessories, in the U.S. call 480-967-3565 or FAX 480-967-8132. For all other countries, call +001-480-967-3565 or FAX +001-480-967-8132.

PRACTICE SAFE SOUND™

CONTINUOUS EXPOSURE TO SOUND PRESSURE LEVELS OVER 100dB MAY CAUSE PERMANENT HEARING LOSS. HIGH POWERED AUTOSOUND SYSTEMS MAY PRODUCE SOUND PRESSURE LEVELS WELL OVER 130dB. USE COMMON SENSE AND PRACTICE SAFE SOUND.

If, after reading your manual, you still have questions regarding this product, we recommend that you see your Rockford Fosgate dealer. If you need further assistance, you can call us direct at 1-800-669-9899. Be sure to have your serial number, model number and date of purchase available when you call.

The serial number can be found on the outside of the box. Please record it in the space provided below as your permanent record. This will serve as verification of your factory warranty and may become useful in recovering your product if it is ever stolen.

Serial Number: _____

Model Number: _____

TABLE OF CONTENTS

| | |
|----------------------------------|----|
| Introduction | 1 |
| Package Contents..... | 2 |
| Installation Considerations..... | 3 |
| Mounting Location | 4 |
| Installation | 5 |
| Troubleshooting | 9 |
| Specifications | 10 |
| Warranty Information | 12 |
| International Information | 13 |

INTRODUCTION

This manual provides information on the features and installation of the fanaticX Systems. We suggest you save this manual for future reference. We strongly recommend you have your Authorized Rockford Fosgate Dealer install the fanaticX System. If you do choose to install the system yourself, please be sure to read the entire manual before beginning.

PACKAGE CONTENTS

FNX1414 4" fanaticX Component System

- | | |
|--|------------------------------------|
| (2) FNX2401 Tweeters Includes 3/4" [20mm] silk dome tweeter, flush mount housing, sur- face mount housing, wedge mount housing | (2) .110 Female Fast-on Connectors |
| (2) Tweeter Mounting Brackets | (2) .110 Male Fast-on Connectors |
| (4) #8-32 x .500 Screws | (2) FNX1404 4" Midrange Speakers |
| (8) #8 x .75 Phillips Screws | (2) 4" Speaker Grilles |
| | (2) 4" Speaker Grille Rings |
| | (2) FNX242x 2-Way Crossovers |
| | (8) #8 x 1.25 Phillips Screws |
| | (20') 18 Gauge Speaker Wire |

FNX1514 5-1/4" fanaticX Component System

- | | |
|--|--------------------------------------|
| (2) FNX2401 Tweeters Includes 3/4" [20mm] silk dome tweeter, flush mount housing, surface mount housing, wedge mount housing | (2) .110 Female Fast-on Connectors |
| (2) Tweeter Mounting Brackets | (2) .110 Male Fast-on Connectors |
| (4) #8-32 x .500 Screws | (2) FNX1405 5-1/4" Midrange Speakers |
| (8) #8 x .75 Phillips Screws | (2) 5-1/4" Speaker Grilles |
| | (2) 5-1/4" Speaker Grille Rings |
| | (2) FNX242x 2-Way Crossovers |
| | (8) #8 x 1.25 Phillips Screws |
| | (20') 18 Gauge Speaker Wire |

FNX1614F 6" fanaticX Component System

- | | |
|--|------------------------------------|
| (2) FNX2401 Tweeters Includes 3/4" [20mm] silk dome tweeter, flush mount housing, sur- face mount housing, wedge mount housing | (2) .110 Female Fast-on Connectors |
| (2) Tweeter Mounting Brackets | (2) .110 Male Fast-on Connectors |
| (4) #8-32 x .500 Screws | (2) FNX1406F 6" Midrange Speakers |
| (8) #8 x .75 Phillips Screws | (2) 6" Speaker Grilles |
| | (2) 6" Speaker Grille Rings |
| | (2) FNX242x 2-Way Crossovers |
| | (8) #8 x 1.25 Phillips Screws |
| | (20') 18 Gauge Speaker Wire |

FNX1614 6-1/2" fanaticX Component System

- | | |
|--|--------------------------------------|
| (2) FNX2401 Tweeters Includes 3/4" [20mm] silk dome tweeter, flush mount housing, sur- face mount housing, wedge mount housing | (2) .110 Female Fast-on Connectors |
| (2) Tweeter Mounting Brackets | (2) .110 Male Fast-on Connectors |
| (4) #8-32 x .500 Screws | (2) FNX1406 6-1/2" Midrange Speakers |
| (8) #8 x .75 Phillips Screws | (2) 6-1/2" Speaker Grilles |
| | (2) 6-1/2" Speaker Grille Rings |
| | (2) FNX242x 2-Way Crossovers |
| | (8) #8 x 1.25 Phillips Screws |
| | (20') 18 Gauge Speaker Wire |

INSTALLATION CONSIDERATIONS

Tools Needed

The following is a list of some of the tools necessary for the installation of your speakers.

| | |
|--------------------------------|-------------------------|
| Power Drill with assorted bits | #2 Phillips Screwdriver |
| Tape Measure | Voltmeter |

General

1. For safety, disconnect the negative lead from the battery prior to beginning the installation.
2. Never run wires underneath the vehicle. Running the wires inside the vehicle provides the best protection.
3. Avoid running wires over or through sharp edges. Use rubber or plastic grommets to protect any wires routed through metal.
4. Mount the speakers/crossovers away from electrical sources (other than the amplifier) i.e., power cables, electronic fuel pumps, vehicle computers, and other potential noise sources.
5. Mount the speakers/crossovers away from areas of extreme heat or moisture.

Speakers

1. Make sure there is an area large enough of the speaker to mount.
Warning! Failure to do this can cause damage to the speaker if the speaker frame is bent during installation.
 2. Check to see that the location is deep enough for the speaker(s) and the location does not interfere with the normal operation of the vehicle.
 3. When mounting the speaker(s) in the door of a vehicle, make sure the speaker(s) do not interfere with either the door or window operation.
 4. When mounting the speaker(s) on the rear deck of the vehicle, check the operation of the rear hatch or trunk lid. Make sure the torsion bars and other moving parts are not obstructed by the speaker(s) installation.
- Please refer to the Specifications section of this manual for proper mounting diameter and depth of the speaker(s).

Crossovers

1. Make sure there is a flat area large enough for the crossover to mount.
2. For best results, mount the crossover(s) next to the amplifier for a decorative finish to the installation and provide an easy upgrade (no new wires to run) for a bi-amp Rockford Fosgate system in the future.

MOUNTING LOCATION

A solid front stage with a good image is one of the most difficult tasks to achieve in a vehicle. No car has the optimum listening environment. This makes proper sound staging very difficult to accomplish. Most speakers tend to be placed where they will fit easily, as opposed to where they can perform the best. The mounting location of your speakers will have a great effect on the sound quality of your stereo system. The special care taken to place the speakers will yield many hours of listening enjoyment in return. Several important recommendations should be followed.

- Place the speakers where they have a direct path to the listening area.
- For the best integration between the midrange and tweeter, the tweeter should be placed less than 2" from the midrange. (Figure 1)

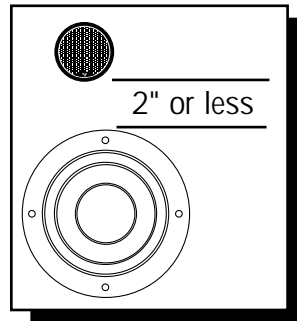

Figure 1

- If you cannot place the tweeter less than 2" from the midrange, then place the tweeter more than 7" from the midrange. Placing the tweeter 2"-7" from the midrange can cause destructive interference (frequency response problems) which will affect the speaker's ability to reproduce the frequency range around the crossover frequency of the system.
- Whenever possible, place the tweeter directly above or below the midrange as this maximizes the imaging (point source) capability of the speakers. (Figure 2)

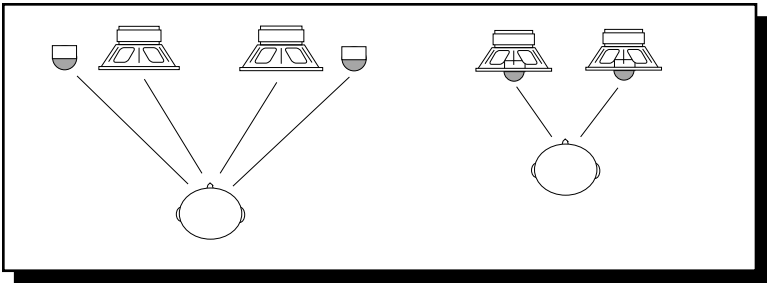

Figure 2-A

Figure 2-B

- Sound radiated from a “point source” has the most optimum stereo imaging because the separation of the acoustical centers between the midrange and tweeter for each channel is at the optimum. Figure 2-A describes a horizontal speaker alignment. In a closed environment such as an automobile, horizontal speaker alignment can cause severe amplitude and phase differences which will degrade not only the imaging, but also the frequency response. This is due to the path length differences between the midrange and tweeter. Figure 2-B displays a vertical alignment between the midrange and tweeter. With a vertical alignment, the path length difference between the midrange and tweeter are reduced to a minimum. The result is a negligible difference in path lengths between the midrange and tweeter regardless of the proximity of the listener to the speakers. Mounting the speaker with minimum path length difference will ensure the best staging and imaging possible from your audio system.

INSTALLATION

Mounting the Midrange

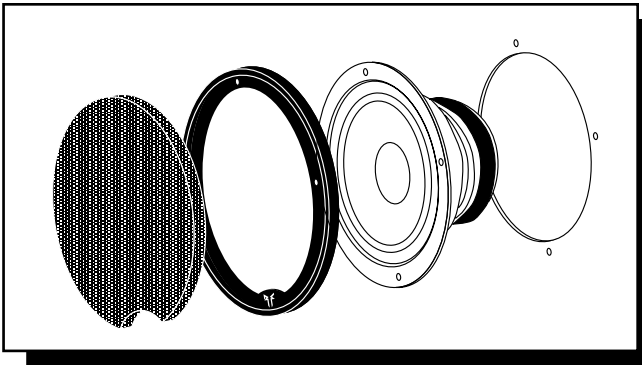

1. Cut the proper size hole for the midrange/woofer (refer to the specifications page for mounting diameter dimensions)
2. Place the midrange over the mounting hole and mark the location of the screw mounting holes.
3. Remove the midrange. Drill the holes for the screws using a 1/8" drill bit.
4. Route the wire through the hole.
5. Attach the wires and be sure to observe the proper speaker polarity.
6. Place the speaker into the hole and screw the speaker into place. Be careful not to bend the speaker frame during this step.
7. Press the speaker grille into the mounting ring.

Flush Mount Tweeter

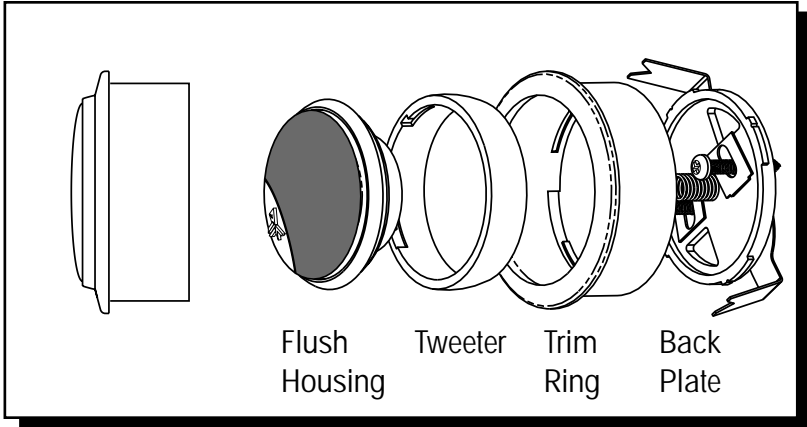

Surface Mount Tweeter

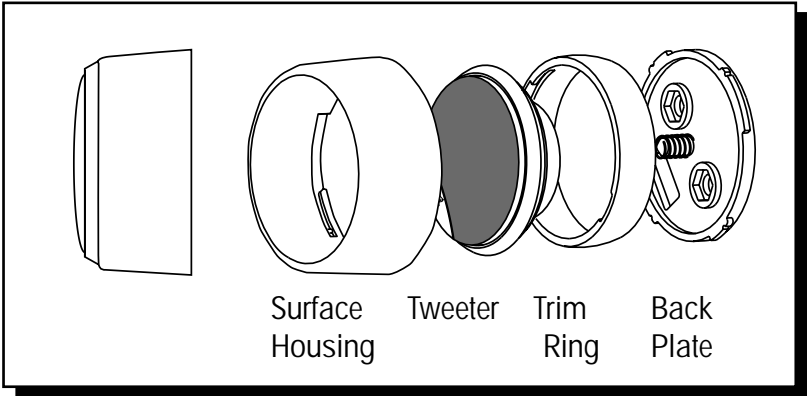

Wedge Mount Tweeter

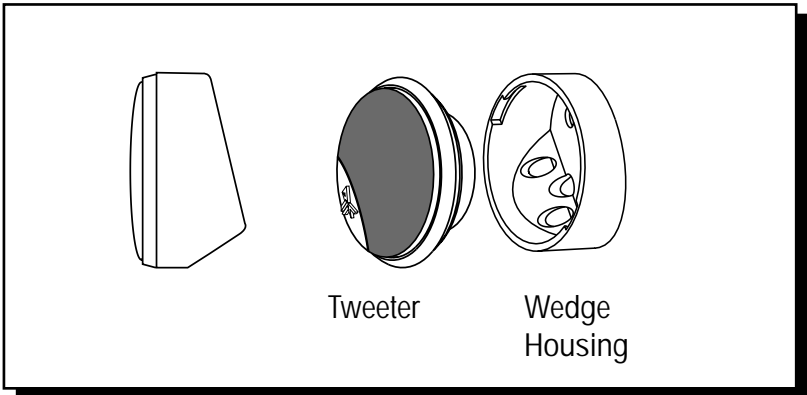

Crossover Connections Model 242X

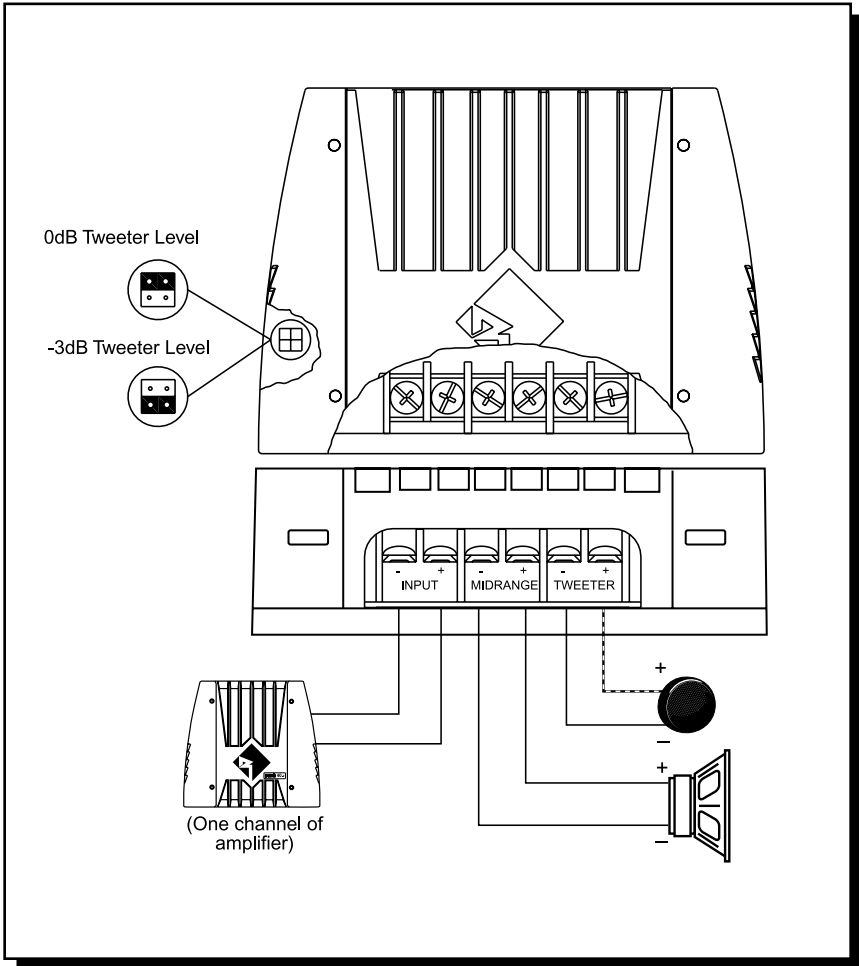

- **Be Sure to Maintain Speaker Polarity**
- **0dB Tweeter Level** matches the amplitude of the tweeter to the midrange
- **-3dB/-6dB Tweeter Level** reduces the amplitude of the tweeter -3dB or -6dB lower than the midrange. (ex. ideal for tweeters located high in door panels and midranges located low in the kick panel)
- **0°/180° Tweeter Phase** matches the phase response of the tweeter to the midrange (eminent when tweeter is located away from the midrange). Leave the switch in the position that results in the best sound quality.
- **Replaceable Tweeter Protection Bulb** - The light bulb acts as a fuse to protect against overload. If the bulb burns out, remove the burned out bulb and insert a new bulb (part# HDW10932) into the retainer clips.

Bandpassing the Midrange

- The Fanatic Component Systems are optimized for full range music reproduction. In cases where a subwoofer is used, the midrange can be bandpassed in order to prevent overlapping frequencies from the midrange into the subwoofer.
- Determine the frequency range that the subwoofer will play (i.e.: 20Hz-80Hz)
 - Use the low-pass crossover frequency of the subwoofer system (i.e.: 80Hz) as the high-pass crossover frequency for the midrange
 - Select the appropriate capacitor value (i.e.: 500 μ F) to properly band-pass the midrange
 - Place the capacitor in series with the "+" terminal of the speaker

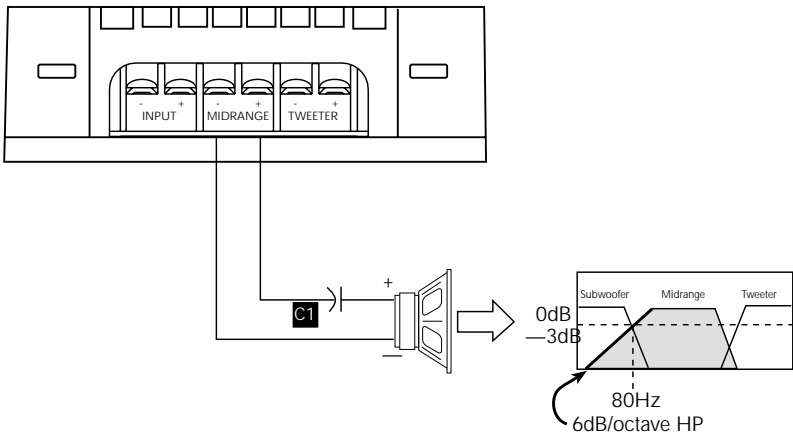

| Frequency (Hertz) | Speaker (4 ohms) |
|----------------------|---------------------|
| | |
| 80Hz | 500 μ F |
| 100Hz | 400 μ F |
| 130Hz | 300 μ F |
| 200Hz | 200 μ F |
| 260Hz | 150 μ F |
| 400Hz | 100 μ F |

TROUBLESHOOTING

| Symptom | Diagnosis | Remedy |
|---|--|---|
| No sound from speakers | Wires between amplifier, crossover or speakers not connected properly. | Check and repair or replace wiring as needed. |
| | Amplifier has no output. | Check system with known working amplifier and repair or replace as needed. |
| | Speaker wires are shorted to each other or to the chassis of the vehicle. | Check for shorts in the wiring with a volt/ohm meter and repair or replace wires as needed |
| | Speakers are blown. | Check system with known working speaker and repair or replace as needed. |
| Distorted sound from speakers | Incorrect wiring between crossover and speakers | Check wiring and repair or replace as needed. |
| Tweeters “burn up” easily | Excessive power from amplifier | Check gain settings on amplifier and readjust as necessary |
| | Equalizer in system (if available) has excessive boost in the high frequency range | Check settings on equalizer and readjust as necessary |
| Engine noise from one or more speakers | Speaker wires shorted to chassis of vehicle. | Check for shorts in the wiring with a volt/ohm meter and repair or replace wires as needed. |
| | Speaker wires are routed near radiated noise source. (Power cables, vehicle computers, etc.) | Re-route speaker wiring away from noise sources. (Refer to the Installation Considerations section of this manual.) |
| | Crossover is mounted near radiated noise source. (Power cables, vehicle computers, etc.) | Move crossovers away from noise sources. (Refer to the Installation Considerations section of this manual.) |

SPECIFICATIONS

| System Model Number | FNX1414 | FNX1514 | FNX1614F | FNX1614 |
|------------------------------|--|--|---|--|
| Midrange Model Number | FNX1404 | FNX1405 | FNX1406F | FNX1406 |
| Nominal Diameter | 4" | 5 ¹ / ₄ " | 6" | 6 ¹ / ₂ " |
| Nominal Impedance | 4Ω | 4Ω | 4Ω | 4Ω |
| Frequency Response | 90Hz-8kHz | 60Hz-6kHz | 61Hz-6kHz | 50Hz-5kHz |
| Fs (Hz) | 90Hz | 60Hz | 61Hz | 50Hz |
| Qes | .858 | .507 | .507 | .545 |
| Qms | 4.363 | 3.303 | 3.330 | 3.508 |
| Qts | .717 | .440 | .439 | .472 |
| Vas (ft ³ /liter) | .08/2.4 | .26/7.5 | .31/8.8 | .72/20.3 |
| Xmax (in/mm) | .11/2.9 | .15/3.7 | .15/3.7 | .15/3.7 |
| Sensitivity | 84.8dB | 87.4dB | 87.9dB | 88.4dB |
| RMS Power Handling | 70 Watts | 70 Watts | 70 Watts | 70 Watts |
| Mounting Diameter | 90.48mm (3 ⁹ / ₁₆ " | 113.50mm (4 ¹⁵ / ₃₂ " | 127mm (5") | 139.06mm (5 ¹ / ₂ " |
| Mounting Depth | 54mm (2 ¹ / ₈ " | 60mm (2 ³ / ₈ " | 63mm (2 ¹⁵ / ₃₂ " | 65mm (2 ⁹ / ₁₆ " |

| Model | FNX2401 |
|--------------------|--------------|
| Nominal Diameter | 3/4" (20mm) |
| Nominal Impedance | 4Ω |
| Frequency Response | 1.8kHz-20kHz |
| Fs | 1.8kHz |
| Sensitivity | 93dB |
| RMS Power Handling | 70 Watts* |
| Mounting Diameter | See drawings |
| Mounting Depth | See drawings |

| Model | FNX142x |
|---------------------|--|
| Crossover Type | 2-Way |
| Crossover Frequency | 4kHz @ 4Ω |
| Crossover Slope | 18dB/octave High-Pass 6dB/octave Low-Pass |
| Filter Q | 0.707 (Butterworth) |
| Tweeter Protection | Optical Compression |
| Tweeter Pad | 0dB/-3dB |

* Power Ratings (PE) is established with recommended filter network

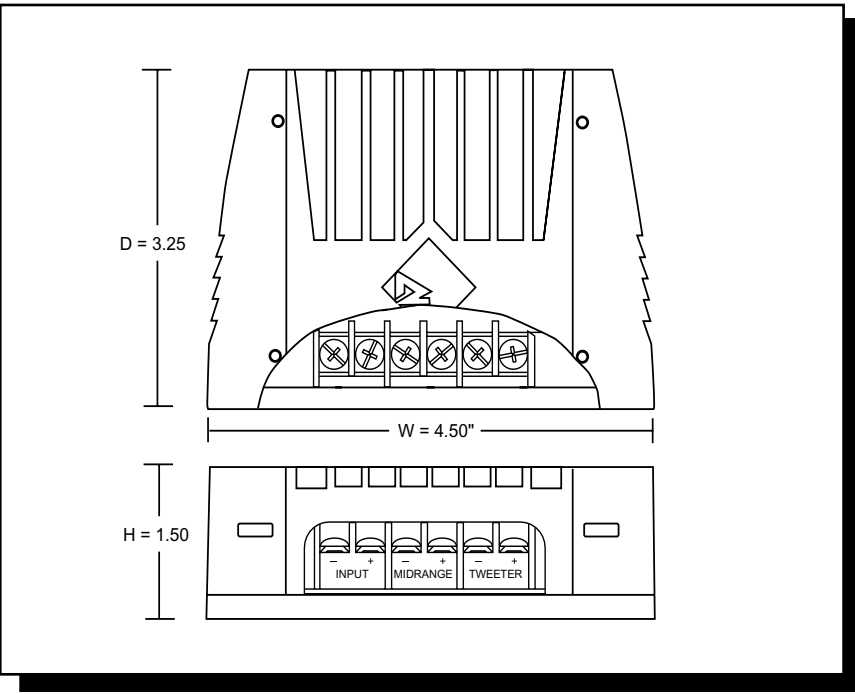
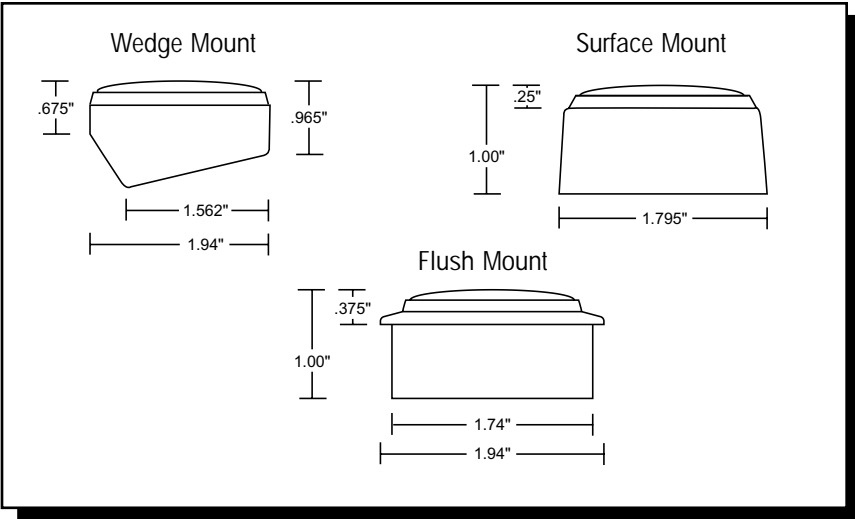

(Specifications are subject to change without notice)

LIMITED WARRANTY INFORMATION

Rockford Corporation offers a limited warranty on Rockford Fosgate products on the following terms:

- **Length of Warranty**

1 year on speakers 30 days on speaker B-stock (receipt required)
3 years on electronics 90 days on electronic B-stock (receipt required)
2 years on source units

- **What is Covered**

This warranty applies only to Rockford Fosgate products sold to consumers by Authorized Rockford Fosgate Dealers in the United States of America or its possessions. Product purchased by consumers from an Authorized Rockford Fosgate Dealer in another country are covered only by that country's Distributor and not by Rockford Corporation.

- **Who is Covered**

This warranty covers only the original purchaser of Rockford product purchased from an Authorized Rockford Fosgate Dealer in the United States. In order to receive service, the purchaser must provide Rockford with a copy of the receipt stating the customer name, dealer name, product purchased and date of purchase.

- Products found to be defective during the warranty period will be repaired or replaced (with a product deemed to be equivalent) at Rockford's discretion.

- **What is Not Covered**

1. Damage caused by accident, abuse, improper operations, water, theft
2. Any cost or expense related to the removal or reinstallation of product
3. Service performed by anyone other than Rockford or an Authorized Rockford Fosgate Service Center
4. Any product which has had the serial number defaced, altered, or removed
5. Subsequent damage to other components
6. Any product purchased outside the U.S.
7. Any product not purchased from an Authorized Rockford Fosgate Dealer

- **Limit on Implied Warranties**

Any implied warranties including warranties of fitness for use and merchantability are limited in duration to the period of the express warranty set forth above. Some states do not allow limitations on the length of an implied warranty, so this limitation may not apply. No person is authorized to assume for Rockford Fosgate any other liability in connection with the sale of the product.

- **How to Obtain Service**

Please call 1-800-669-9899 for Rockford Customer Service. You must obtain an RA# (Return Authorization number) to return any product to Rockford Fosgate. You are responsible for shipment of product to Rockford.

Ship to: Electronics
Rockford Corporation
Warranty Repair Department
2055 E. 5th Street
Tempe, AZ 85281
RA#: _____

Ship to: Speakers
Rockford Acoustic Design
(Receiving-speakers)
609 Myrtle N.W.
Grand Rapids, MI 49504
RA#: _____

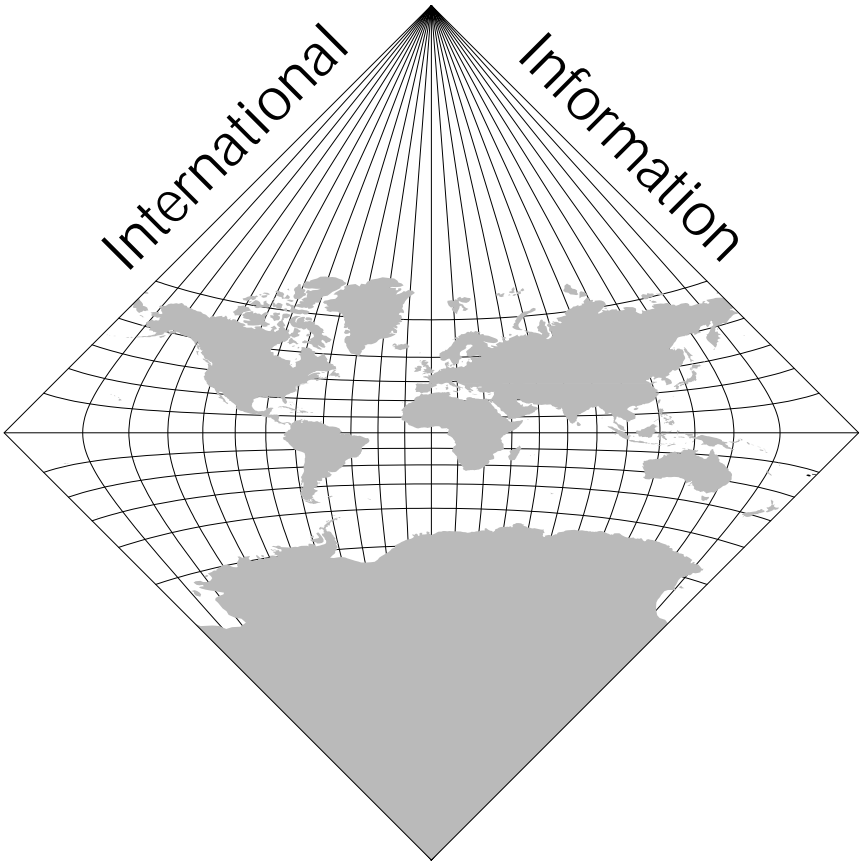

LEA DETENIDAMENTE LAS SIGUIENTES INSTRUCCIONES DE INSTALACIÓN DEL PRODUCTO.

INTRODUCCIÓN

Este manual contiene información sobre la construcción, instalación y funcionamiento de los sistemas Fanatic X. Le recomendamos que conserve el manual para futuras consultas.

Es preferible que la instalación de sistema Fanatic X sea realizada por un distribuidor autorizado Rockford Fosgate. Si prefiere realizar la instalación usted mismo, asegurese de leer el manual en su totalidad antes de comenzar.

MONTAJE

- Le mejor interacción entre tweeter y medio se consigue si no están separados entre si más de 5 centímetros. (Figura 1)

INSTALACIÓN

Montaje del altavoz de medios



Figura 1



1. Corte el agujero para el medio/woofer.
2. Use los anillos de midrange como plantilla. Marque la posición de los tornillos de anclaje.
3. Quite el anillo y perfore los agujeros con una broca de 1/8".
4. Pase el cable de altavoz a través del agujero.
5. Conecte los cables observando la polaridad. Mantenga los cables alejados de partes móviles o cortantes.

6. Asegure el altavoz en la abertura con los tornillos. Tenga la precaución de no doblar el marco del altavoz en este proceso.
7. Presione la rejilla en el anillo de montaje.

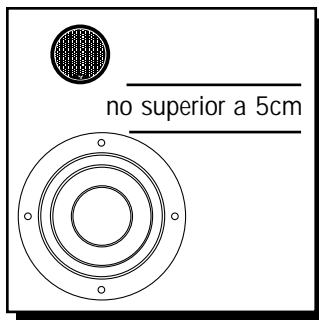
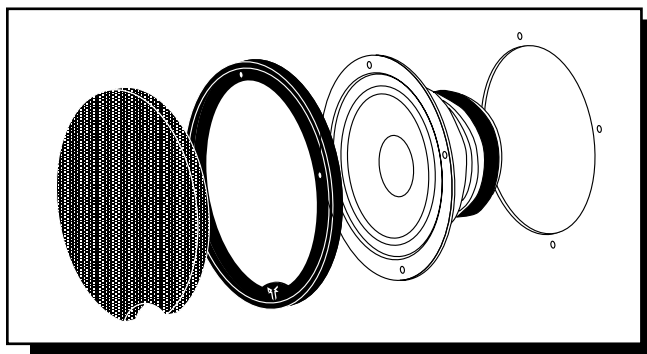
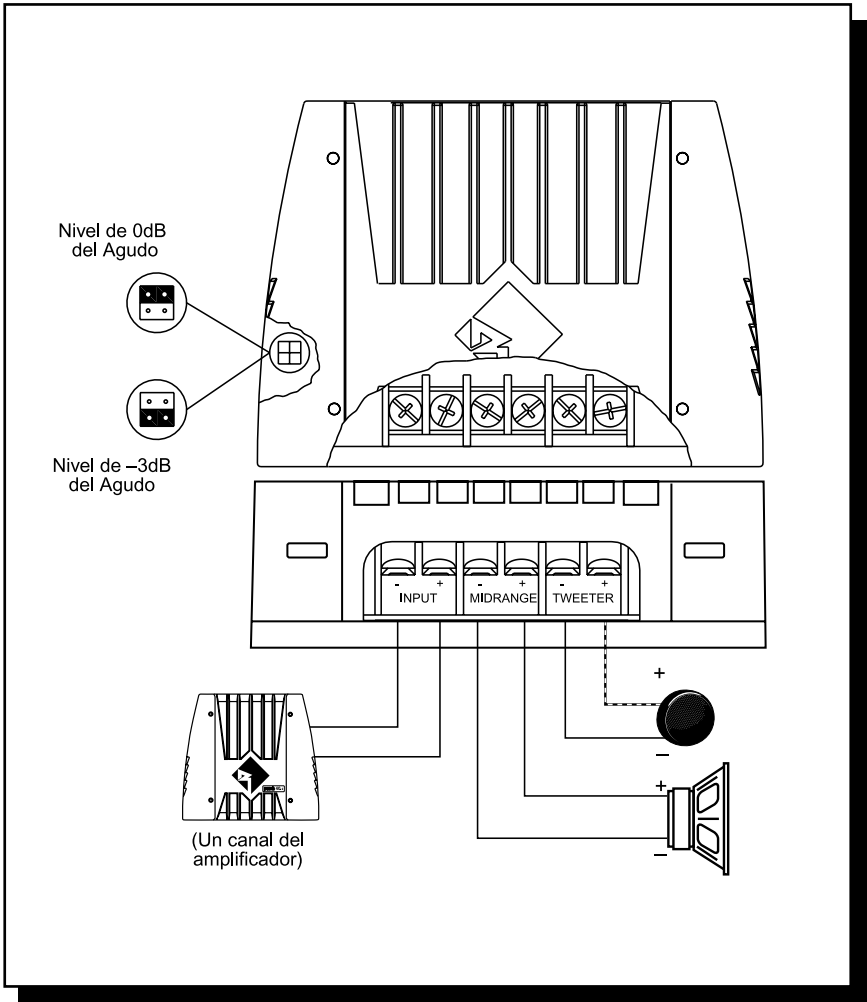

VEUILLEZ LIRE LES INSTRUCTONS SUIVANTES POUR L'INSTALLATION DE CES PRODUITS.

INTRODUCTION

Ce manuel contient des informations sur les caractéristiques et l'installation des systèmes Fanatic X. Nous vous proposons de garder ce manuel pour toute référence future.

Nous vous recommandons vivement de faire installer votre système punch Fanatic X par un dealer agréé Rockford Fosgate. Si vous choisissez d'installer le système vous même, assurez-vous de lire ce manuel entièrement avant de commencer.

EMPLACEMENT DE MONTAGE

- Pour bénéficier d'une harmonie maximum entre le médium et l'aigu l'éloignement entre ces deux haut-parleurs devrait être de moins de 5 cm entre les 2 chassis. (Figure 1)

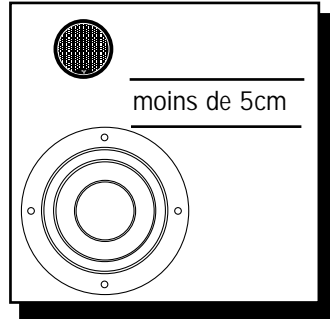
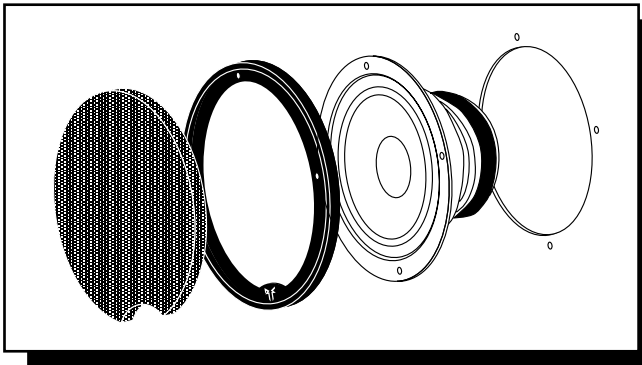

Figure 1

INSTALLATION

Montage du haut-parleur médium



1. Découper un trou adapté au haut-parleur médium/woofer.
2. Placer médium/woofer sur le trou et repérer l'emplacement des trous des vis.
3. Percer les trous des vis en utilisant une mèche de 3mm.
4. Faire passer les fils dans le trou central.
5. Connecter les fils au haut-parleur en respectant les polarités. Eloigner les fils de toute partie tranchante ou mobile du véhicule.

- Placer le haut-parleur au-dessus du trou central. Visser le haut-parleur dans son emplacement. Faire attention à ne pas tordre le châssis du haut-parleur durant cette étape de montage.
- Mettre la grille dans l'anneau de montage.

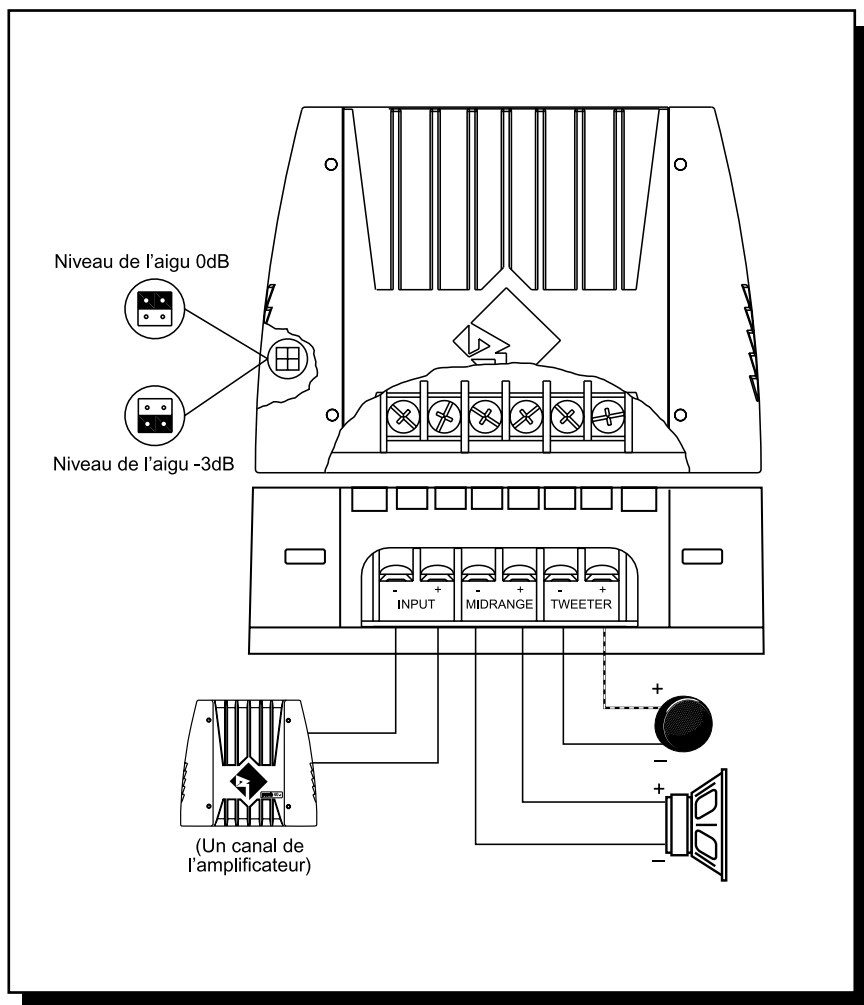

DIE FOLGENDE BEDIENUNGSANLEITUNG SOLL IHNEN BEIM EINBAU EINE HILFESTELLUNG GEBEN.

ENLEITUNG

Diese Bedienungsanleitung enthält Informationen für den Gebrauch und Einbau des Fanatic X Systems. Wir empfehlen, diese auch für Fragen in der Zukunft sorgfältig aufzubewahren.

Es ist empfehlenswert, sich das Fanatic X System von einem Autorisierten Rockford Fosgate Fachhändler einbauen zu lassen. Sollten Sie den Einbau jedoch selber vornehmen wollen, so empfehlen wir Ihnen, die Bedienungsanleitung sorgfältig zu lesen.

EINBAUORT

- Für das optimale Zusammenspiel von Mittel- und Hochtönen, sollte der Hochtöner niemals weiter als 5cm vorn Mitteltoner entfernt montiert werden. (Abb. 1)

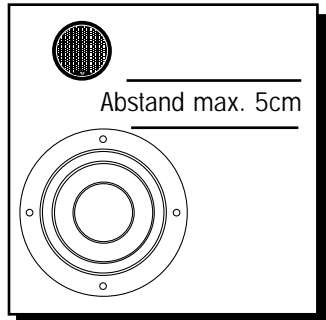

(Abb. 1)

EINBAU

Montage des Mitteltöners

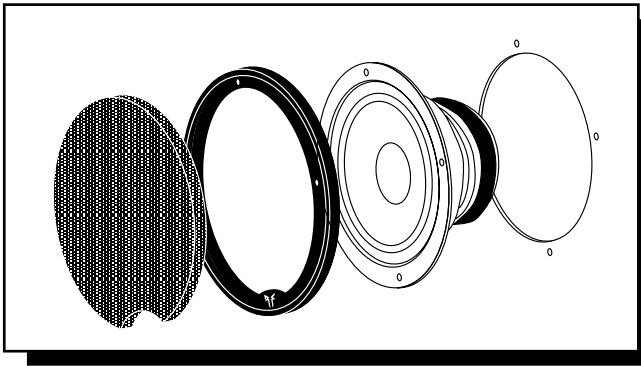

1. Schneiden Sie die richtige Lochgröße für den Mitteltöner oder Midbass aus.
2. Setzen Sie den Mitteltöner auf das Loch und markieren Sie die Löcher für die Schrauben.
3. Nehmen Sie den Mitteltöner wieder ab und bohren Sie dann, mit einem passenden Bohrer, die Schraubenlöcher vor.
4. Führen Sie das Kabel durch das Loch.

5. Schließen Sie die Lautsprecherkabel an. Kontrollieren Sie, ob die Polarität stimmt. Stellen Sie sicher, dass das Lautsprecherkabel an keinen scharfen oder sich bewegenden Teilen anliegt.
6. Platzieren Sie den Lautsprecher im Loch und befestigen Sie diesen. Seien Sie dabei sehr vorsichtig, so dass sich der Lautsprecherkorb nicht verzieht.
7. Drücken Sie das Lautsprechergitter im Montagerring fest.

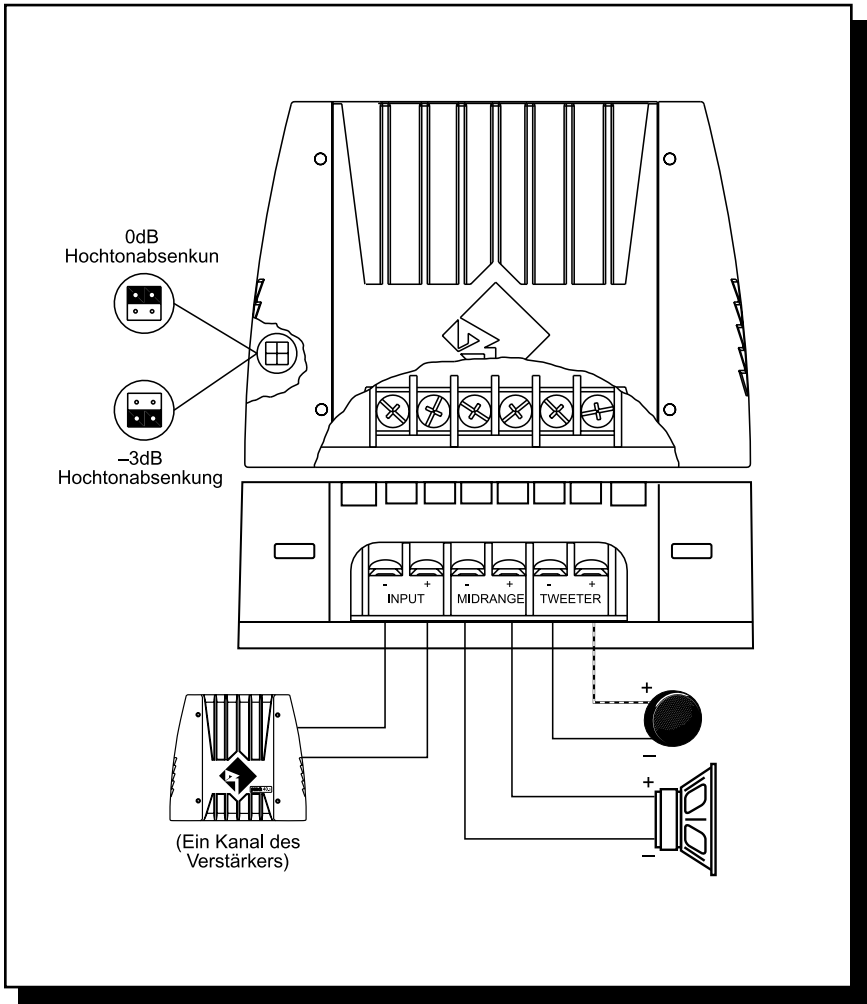

LEGGERE LE ISTRUZIONI SEGUENTI PRIMA DELL'INSTALLAZIONE DEL PRODOTTO.

INTRODUZIONE

Questo manuale fornisce informazioni sulle caratteristiche e sul installazione dei sistemi Fanatic X. Vi suggeriamo di conservare questo manuale come riferimento futuro.

Raccomandiamo fortemente che il sistema sia installato dal vostro rivenditore Rockford Fosgate. Se scegliete di procedere con l'installazione da soli, leggete attentamente tutto il manuale prima di proseguire.

POSIZIONAMENTO

- Per ottenere la miglior integrazione tra tweeter e midrange, vi suggeriamo di posizionare i due componenti a meno di 5 cm tra loro. (Figura 1)

INSTALLAZIONE

Installazione del Midrange



Figura 1



1. Praticate un foro del diametro corretto per il midrange/woofer.
2. Posizionate il midrange sul foro e segnate la posizione delle viti.
3. Togliete il midrange e forate il pannello con una punta da 3mm.
4. Passate i cavi attraverso il foro.
5. Collegate i cavi assicurandovi di osservare la corretta polarità. Assicuratevi di mantenere i cavi lontani da parti in movimento o strutture taglienti.

6. Posizionate l'altoparlante nel foro ed avvitatelo. Assicuratevi di non piegare il cestello dell'altoparlante.
7. Incastrate la griglia sull'anello di fissaggio.

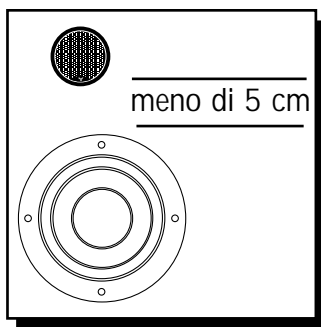
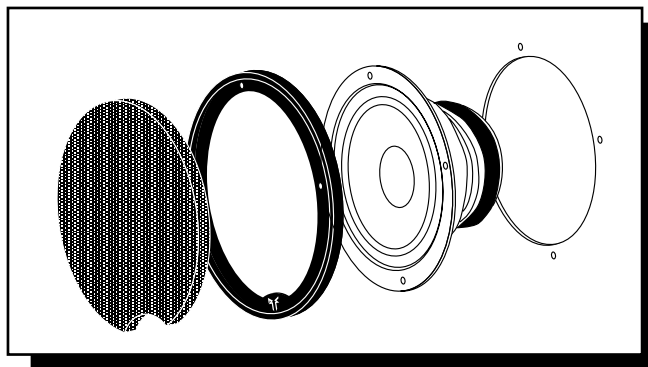
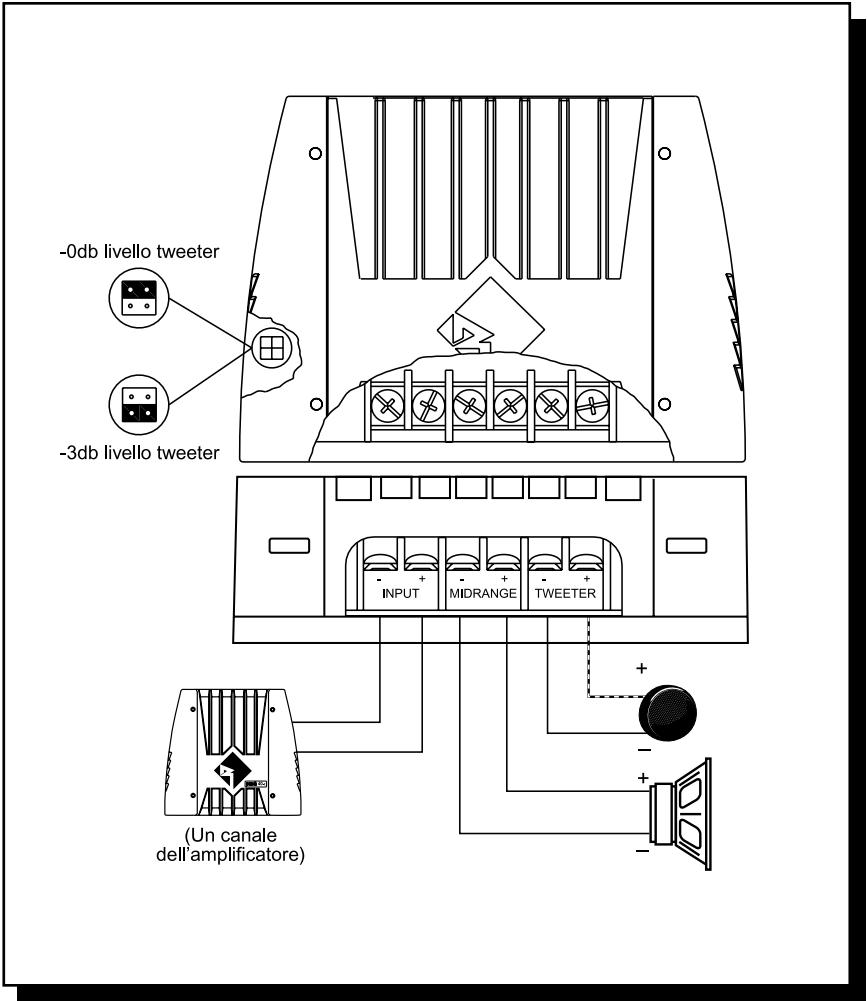

Installation assistance available at:

RFTECH

<http://www.rockfordfosgate.com/rfttech>

MADE IN THE USA

This product is designed, developed and assembled in the USA by a dedicated group of American workers. The majority of the components used in the construction of this product are produced by American companies. However, due to the global nature of their manufacturing facilities and the loudspeaker parts industry in general, some parts may be manufactured in other countries.

Rockford Fosgate
Rockford Corporation
546 South Rockford Drive
Tempe, Arizona 85281 U.S.A.
In U.S.A., (480) 967-3565
In Europe, Fax (49) 8503-934014
In Japan, Fax (81) 559-79-1265
www.rockfordfosgate.com