

FNP2401x

FNX2401x

FNQ2401x



fanatic P

fanatic X

fanatic Q



Operation
& Installation

fanatic

Dear Customer,

Congratulations on your purchase of the world's finest brand of car audio speakers. At Rockford Fosgate we are fanatics about musical reproduction at its best, and we are pleased you chose our product. Through years of engineering expertise, hand craftsmanship and critical testing procedures, we have created a wide range of products that reproduce music with all the clarity and richness you deserve.

For maximum performance we recommend you have your new Rockford Fosgate product installed by an Authorized Rockford Fosgate Dealer, as we provide specialized training through Rockford Technical Training Institute (RTTI). Please read your warranty and retain your receipt and original carton for possible future use.

Great product and competent installations are only a piece of the puzzle when it comes to your system. Make sure that your installer is using 100% authentic installation accessories from Connecting Punch in your installation. Connecting Punch has everything from RCA cables and speaker wire to Power line and battery connectors. Insist on it! After all, your new system deserves nothing but the best.

To add the finishing touch to your new Rockford Fosgate image order your Rockford wearables, which include everything from T-shirts and jackets to hats and sunglasses.

To get a free brochure on Rockford Fosgate products and Rockford accessories, in the U.S. call 480-967-3565 or FAX 480-967-8132. For all other countries, call +001-480-967-3565 or FAX +001-480-967-8132.

PRACTICE SAFE SOUND™

**CONTINUOUS EXPOSURE TO SOUND PRESSURE LEVELS OVER 100dB
MAY CAUSE PERMANENT HEARING LOSS. HIGH POWERED AUTOSOUND
SYSTEMS MAY PRODUCE SOUND PRESSURE LEVELS WELL OVER
130dB. USE COMMON SENSE AND PRACTICE SAFE SOUND.**

If, after reading your manual, you still have questions regarding this product, we recommend that you see your Rockford Fosgate dealer. If you need further assistance, you can call us direct at 1-800-669-9899. Be sure to have your serial number, model number and date of purchase available when you call.

The serial number can be found on the outside of the box. Please record it in the space provided below as your permanent record. This will serve as verification of your factory warranty and may become useful in recovering your product if it is ever stolen.

Serial Number: _____

Model Number: _____

TABLE OF CONTENTS

Introduction	1
Package Contents	1
Installation Considerations	2
Mounting Location	3
Installation	4
Troubleshooting	6
Specifications	7
Warranty Information	9
International Information	10

GETTING STARTED

Welcome to Rockford Fosgate! This manual is designed to provide information for the owner, salesperson and installer. For those of you who want quick information on how to install this product, please turn to the **Installation Section** of this manual or refer to the icons listed below. Other information can be located by using the Table of Contents. We, at Rockford Fosgate, have worked very hard to make sure all the information in this manual is current. But, as we are constantly finding new ways to improve our product, this information is subject to change without notice.



Sections marked **INSTALLATION** include “slam dunk” wiring connections

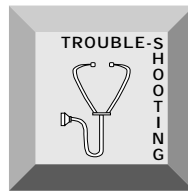

Sections marked **TROUBLESHOOTING** include recommendations for curing installation problems

INTRODUCTION

This manual provides information on the features and installation of the **Fanatic P, X, & Q** Tweeter Systems. We suggest you save this manual for future reference.

We strongly recommend you have your Authorized Rockford Fosgate Dealer install the **Fanatic P, X, or Q** Tweeter System. If you do choose to install the system yourself, please be sure to read the entire manual before beginning.

PACKAGE CONTENTS

FNP2401x

- (2) FNP2401 Tweeters
Includes 3/4" [20mm] mylar dome tweeter, flush mount housing,
surface mount housing, wedge mount housing
- (2) Tweeter Mounting Brackets
- (4) #6 x .500 Screws
- (8) #8 x .75 Phillips Screws
- (2) .110 Female Fast-on Connectors
- (2) .110 Male Fast-on Connectors
- (2) FNP241x High-Pass Crossovers
- (12') 24 gauge Speaker Wire

FNX2401x

- (2) FNX2401 Tweeters
Includes 3/4" [20mm] silk dome tweeter, flush mount housing,
surface mount housing, wedge mount housing
- (2) Tweeter Mounting Brackets
- (4) #6 x .500 Screws
- (8) #8 x .75 Phillips Screws
- (2) .110 Female Fast-on Connectors
- (2) .110 Male Fast-on Connectors
- (2) FNX241x High-Pass Crossovers
- (12') 24 gauge Speaker Wire

FNQ2401x

- (2) FNQ2401 Tweeters
Includes 3/4" [20mm] aluminum dome tweeter, flush mount housing,
surface mount housing, wedge mount housing
- (2) Tweeter Mounting Brackets
- (4) #6 x .500 Screws
- (8) #8 x .75 Phillips Screws
- (2) .110 Female Fast-on Connectors
- (2) .110 Male Fast-on Connectors
- (2) FNQ241x High-Pass Crossovers
- (12') 24 gauge Speaker Wire

INSTALLATION CONSIDERATIONS

Tools Needed

The following is a list of some of the tools necessary for the installation of your speakers.

Power Drill with assorted bits
Tape Measure

#2 Phillips Screwdriver
Voltmeter

General

1. **For safety**, disconnect the negative lead from the battery prior to beginning the installation.
2. Never run wires underneath the vehicle. Running the wires inside the vehicle provides the best protection.
3. Avoid running wires over or through sharp edges. Use rubber or plastic grommets to protect any wires routed through metal.
4. Mount the speakers/crossovers away from electrical sources (other than the amplifier), i.e., power cables, electronic fuel pumps, vehicle computers, and other potential noise sources.
5. Mount the speakers/crossovers away from areas of extreme heat or moisture.

Tweeters

1. When mounting the tweeter(s) in the door of a vehicle, make sure they do not interfere with either the door or window operation.
2. Please refer to the **Specifications** section of this manual for proper mounting diameter and depth of the tweeters.

Crossovers

1. Make sure there is a flat area large enough for the crossover to mount.
2. For best results, mount the crossover(s) next to the amplifier for a decorative finish to the installation and to provide an easy upgrade (no new wires to run) for a bi-amp Rockford Fosgate system in the future.

MOUNTING LOCATION

A solid front stage with a good image is one of the most difficult tasks to achieve in a vehicle. No car has the optimum listening environment. This makes proper sound staging very difficult to accomplish. Most speakers tend to be placed where they will fit easily, as opposed to where they can perform the best. *The mounting location of your speakers will have a great effect on the sound quality of your stereo system. The special care taken to place the speakers will yield many hours of listening enjoyment in return. Several important recommendations should be followed.*

- Place the speakers where they have a direct path to the listening area.
- For the best integration between the midrange and tweeter, the tweeter should be placed less than 2" from the midrange. (Figure 1)
- If you cannot place the tweeter less than 2" from the midrange, then place the tweeter more than 7" from the midrange. Placing the tweeter 2"-7" from the midrange can cause destructive interference (frequency response problems) which will affect the speaker's ability to reproduce the frequency range around the crossover frequency of the system.
- Whenever possible, place the tweeter directly above or below the midrange as this maximizes the imaging (point source) capability of the speakers. (Figure 2)

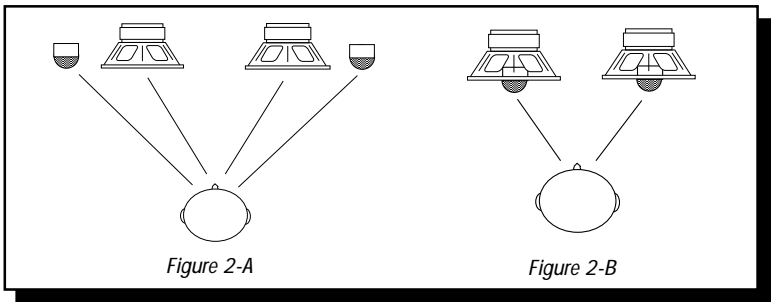
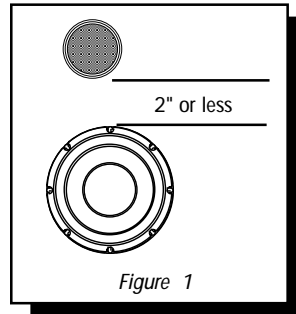

- Sound radiated from a "point source" has the most optimum stereo imaging because the separation of the acoustical centers between the midrange and tweeter for each channel is at the optimum. Figure 2-A describes a horizontal speaker alignment. In a closed environment such as an automobile, horizontal speaker alignment can cause severe amplitude and phase differences which will degrade not only the imaging, but also the frequency response. This is due to the path length differences between the

midrange and tweeter. Figure 2-B displays a vertical alignment between the midrange and tweeter. With a vertical alignment, the path length difference between the midrange and tweeter are reduced to a minimum. The result is a negligible difference in path lengths between the midrange and tweeter regardless of the proximity of the listener to the speakers. Mounting the speaker with minimum path length difference will ensure the best staging and imaging possible from your audio system.

INSTALLATION



Flush Mount Tweeter

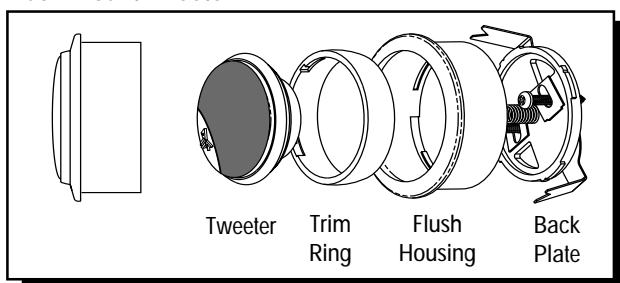

Surface Mount Tweeter

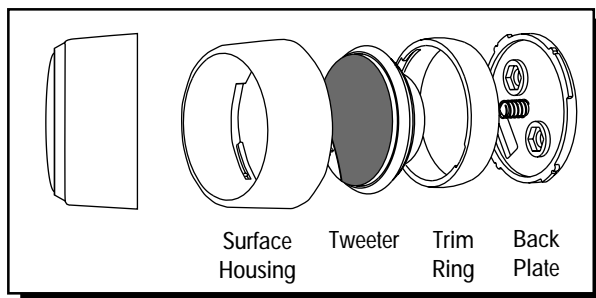

Wedge Mount Tweeter

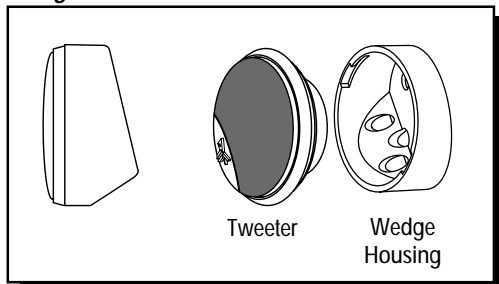

fanatic P Crossover Connections

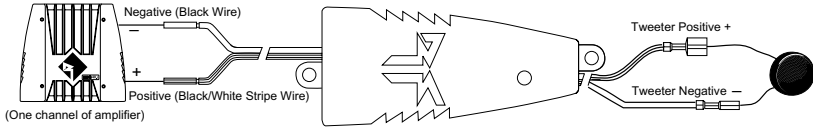

- Be Sure to Maintain Speaker Polarity

fanatic X Crossover Connections

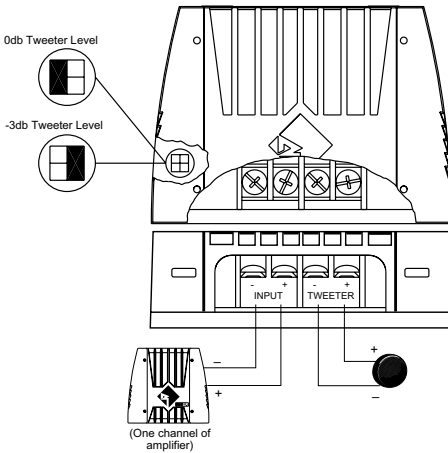

- Be sure to maintain speaker polarity
- 0dB tweeter level matches the amplitude of the tweeter to the midrange
- -3dB tweeter level reduces the amplitude -3dB lower than the midrange (ideal for tweeters located high in door panel and midranges located low in kick panel)
- Replaceable Tweeter Protection Bulb
The light bulb acts as a fuse to protect against overload. If the bulb burns out, remove the burned out bulb and insert a new bulb (part# HDW10932) into the retainer clips.

fanatic Q Crossover Connections

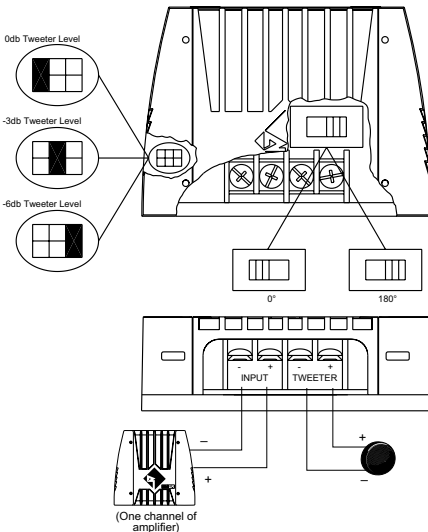

- Be sure to maintain speaker polarity
- 0dB tweeter level matches the amplitude of the tweeter to the midrange
- -3dB/-6dB tweeter level reduces the amplitude -3dB or -6dB lower than the midrange (ideal for tweeters located high in door panel and midranges located low in the kick panel)
- 0°/180° tweeter phase matches the phase response of the tweeter to the midrange. Leave the switch in the position that results in the best sound quality.
- Replaceable Tweeter Protection Bulb
The light bulb acts as a fuse to protect against overload. If the bulb burns out, remove the burned out bulb and insert a new bulb (part# HDW10932) into the retainer clips.

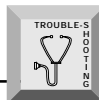

Symptom	Diagnosis	Remedy
No sound from speakers	Wires between amplifier, crossover or speakers not connected properly.	Check and repair or replace wiring as needed.
	Amplifier has no output.	Check system with known working amplifier and repair or replace as needed.
	Speaker wires are shorted to each other or to the chassis of the vehicle.	Check for shorts in the wiring with a volt/ohm meter and repair or replace wires as needed.
	Speakers are blown.	Check system with known working speaker and repair or replace as needed.
Distorted sound from speakers	Incorrect wiring between crossover and speakers	Check wiring and repair or replace as needed.
Tweeters "burn up" easily	Excessive power from amplifier	Check gain settings on amplifier and readjust as necessary
	Equalizer in system (if available) has excessive boost in the high frequency range	Check settings on equalizer and readjust as necessary
Engine noise from one or more speakers	Speaker wires shorted to chassis of vehicle.	Check for shorts in the wiring with a volt/ohm meter and repair or replace wires as needed.
	Speaker wires are routed near radiated noise source. (Power cables, vehicle computers, etc.)	Re-route speaker wiring away from noise sources. (Refer to the Installation Considerations section of this manual.)
	Crossover is mounted near radiated noise source. (Power cables, vehicle computers, etc.)	Move crossovers away from noise sources. (Refer to the Installation Considerations section of this manual.)

SPECIFICATIONS

Tweeter System Model Number	FNP2401x	FNX2401x	FNQ2401x
Tweeter Model Number	FNP2401	FNX2401	FNQ2401
Dome Type	Mylar	Silk	Aluminum
Nominal Diameter	3/4" (20mm)	3/4" (20mm)	3/4" (20mm)
Nominal Impedance	4Ω	4Ω	4Ω
Frequency Response	2.8kHz-20kHz	1.8kHz-20kHz	1.9kHz-20kHz
Sensitivity	91dB	93dB	91dB
RMS Power Handling	50 Watts*	70 Watts*	100 Watts*
Mounting Diameter	See drawings	See drawings	See drawings
Mounting Depth	See drawings	See drawings	See drawings
Crossover Model Number	FNP241x	FNX241x	FNQ241x
Crossover Type	High-Pass	High-Pass	High-Pass
Crossover Frequency	6.3kHz@4Ω	4.0kHz@4Ω	4.0kHz@4Ω
Crossover Slope	18dB/octave HP	18dB/octave HP	24dB/octave HP
Filter Q	0.707 Butterworth	0.707 Butterworth	0.707 Butterworth
Tweeter Protection	Optical Protection	Optical Protection	Optical Protection
Tweeter Pad	N/A	0dB/-3dB	0dB/-3dB/-6dB
Tweeter Phase	N/A	N/A	0° / 180°
Dimensions	See drawings	See drawings	See drawings

* Power Ratings (PE) is established with recommended filter network.

(Specifications are subject to change without notice)

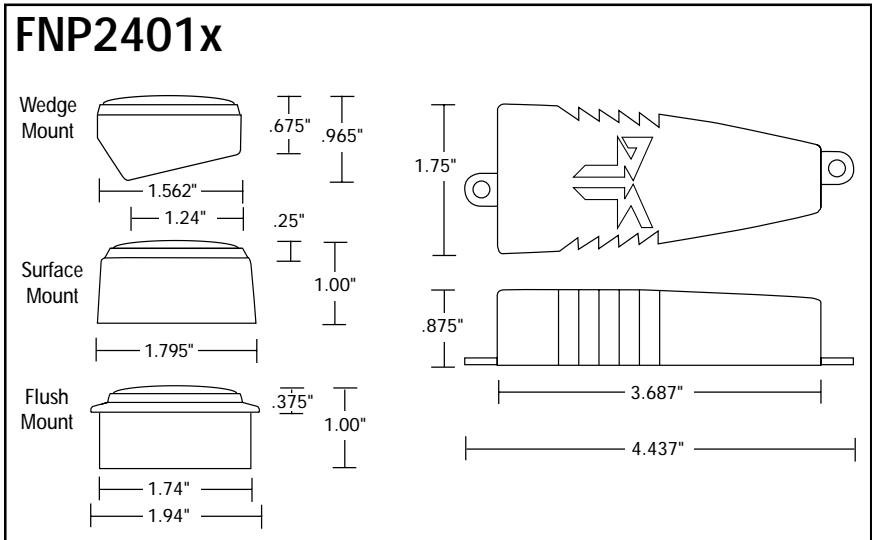

FNX2401x

Wedge Mount

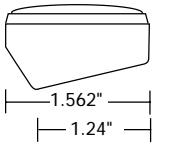

.675" .965"

Surface Mount

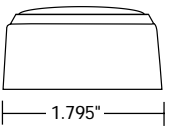

.25" 1.00"

Flush Mount

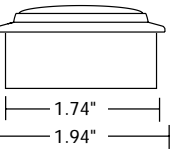

.375" 1.00"

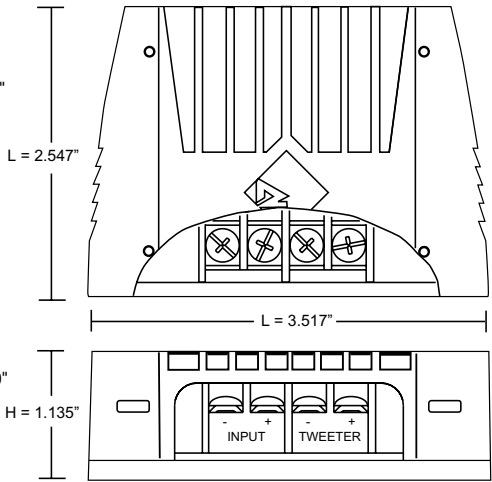

FNQ2401x

Wedge Mount

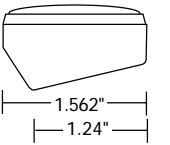

.675" .965"

Surface Mount

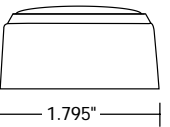

.25" 1.00"

Flush Mount

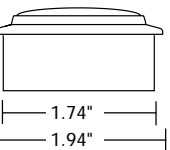

.375" 1.00"

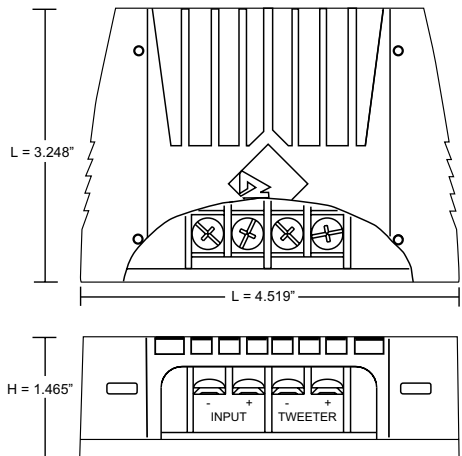

LIMITED WARRANTY INFORMATION

Rockford Corporation offers a limited warranty on Rockford Fosgate products on the following terms:

- **Length of Warranty**

1 year on speakers	30 days on speaker B-stock (receipt required)
3 years on electronics	90 days on electronic B-stock (receipt required)
2 years on source units	

- **What is Covered**

This warranty applies only to Rockford Fosgate products sold to consumers by Authorized Rockford Fosgate Dealers in the United States of America or its possessions. Product purchased by consumers from an Authorized Rockford Fosgate Dealer in another country are covered only by that country's Distributor and not by Rockford Corporation.

- **Who is Covered**

This warranty covers only the original purchaser of Rockford product purchased from an Authorized Rockford Fosgate Dealer in the United States. In order to receive service, the purchaser must provide Rockford with a copy of the receipt stating the customer name, dealer name, product purchased and date of purchase.

- **Products found to be defective during the warranty period will be repaired or replaced (with a product deemed to be equivalent) at Rockford's discretion.**

- **What is Not Covered**
 1. Damage caused by accident, abuse, improper operations, water, theft
 2. Any cost or expense related to the removal or reinstallation of product
 3. Service performed by anyone other than Rockford or an Authorized Rockford Fosgate Service Center
 4. Any product which has had the serial number defaced, altered, or removed
 5. Subsequent damage to other components
 6. Any product purchased outside the U.S.
 7. Any product not purchased from an Authorized Rockford Fosgate Dealer

- **Limit on Implied Warranties**

Any implied warranties including warranties of fitness for use and merchantability are limited in duration to the period of the express warranty set forth above. Some states do not allow limitations on the length of an implied warranty, so this limitation may not apply. No person is authorized to assume for Rockford Fosgate any other liability in connection with the sale of the product.

- **How to Obtain Service**

Please call 1-800-669-9899 for Rockford Customer Service. You must obtain an RA# (Return Authorization number) to return any product to Rockford Fosgate. You are responsible for shipment of product to Rockford.

Ship to: **Electronics**
Rockford Corporation
Warranty Repair Department
2055 E. 5th Street
Tempe, AZ 85281
RA#: _____

Ship to: **Speakers**
Rockford Acoustic Design
(Receiving-speakers)
609 Myrtle N.W.
Grand Rapids, MI 49504
RA#: _____



LEA DETENIDAMENTE LAS SIGUIENTES INSTRUCCIONES DE INSTALACIÓN DEL PRODUCTO.

INTRODUCCIÓN

Este manual contiene información sobre la construcción, instalación y funcionamiento de los Fanatic P, X y Q tweeters. Le recomendamos que conserve el manual para futuras consultas.

Es preferible que la instalación de los tweeters Fanatic P, X y Q sea realizada por un distribuidor autorizado Rockford Fosgate. Si prefiere realizar la instalación usted mismo, asegurese de leer el manual en su totalidad antes de comenzar.

MONTAJE

- Le mejor interacción entre tweeter y medio se consigue si no están separados entre si más de 5 centímetros. (Figura 1)

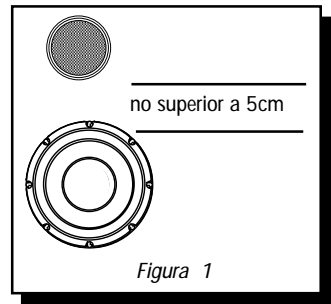

INSTALACIÓN

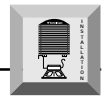

Conexiones del Crossover – fanatic P

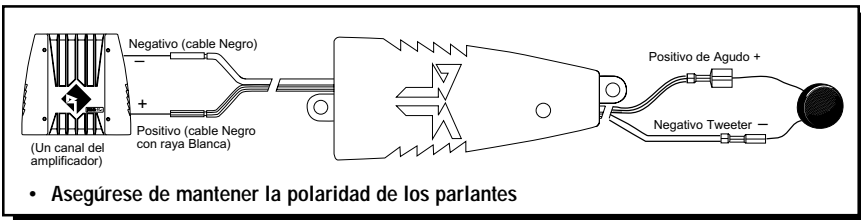



Conexiones del Crossover – fanatic X

Nivel de 0dB del Agudo
 Nivel de -3dB del Agudo

INPUT +
 TWEETER +

(Un canal del amplificador)

- Asegúrese de mantener la polaridad de los parlantes
- Nivel de 0dB del Agudo cuadra con la amplitud del Agudo al Mediorango
- Nivel de -3dB del Agudo reduce la amplitud del Agudo -3dB más bajo que el mediorango. (Ej. Ideal para agudos colocados en paneles de puerta elevados y mediorangos localizados en paneles bajos – kick panel)
- Bombilla recambiable de protección del altavoz de alta frecuencia La bombilla de luz actúa como un fusible para proteger contra sobrecargas. Si la bombilla se quema, saque la bombilla quemada e inserte una bombilla nueva (pieza N° HDW10932) en las grapas de sujeción.

Conexiones del Crossover – fanatic Q

Nivel de 0dB del Agudo
 Nivel de -3dB del Agudo
 Nivel de -6dB del Agudo

0° 180°

INPUT +
 TWEETER +

(Un canal del amplificador)

- Asegúrese de mantener la polaridad de los parlantes
- Nivel de 0dB del Agudo cuadra con la amplitud del Agudo al Mediorango
- Nivel del Agudo -3dB/-6dB reduce la Amplitud del agudo -3dB ó -6dB más bajo que el mediorango. (Ej. Ideal para agudos colocados en paneles de puerta elevados y mediorangos localizados en paneles bajos – kick panel)
- Fase del Agudo 0/180° ajusta la respuesta de fase del agudo al mediorango (eminente cuando el agudo está colocado lejos del mediorange). Deje el conmutador en la posición que resulte con la mejor calidad de sonido.
- Bombilla recambiable de protección del altavoz de alta frecuencia La bombilla de luz actúa como un fusible para proteger contra sobrecargas. Si la bombilla se quema, saque la bombilla quemada e inserte una bombilla nueva (pieza N° HDW10932) en las grapas de sujeción.

Veillez lire les instructions suivantes pour l'installation de ces produits.

INTRODUCTION

Ce manuel contient des informations sur les caractéristiques et l'installation des médium et l'aigu Fanatic P, X et Q. Nous vous proposons de garder ce manuel pour toute référence future.

Nous vous recommandons vivement de faire installer votre des médium et l'aigu Fanatic P, X et Q par un dealer agréé Rockford Fosgate. Si vous choisissez d'installer le système vous même, assurez-vous de lire ce manuel entièrement avant de commencer.

EMPLACEMENT DE MONTAGE

- Pour bénéficier d'une harmonie maximum entre le médium et l'aigu l'éloignement entre ces deux haut-parleurs devrait être de moins de 5 cm entre les 2 chassiss. (Figure 1)

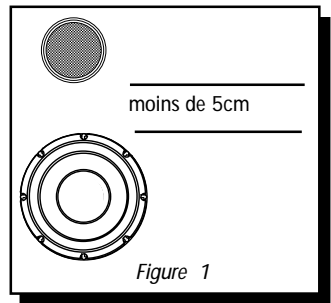

INSTALLATION

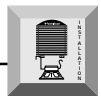

Connexion du filtre – fanatic P

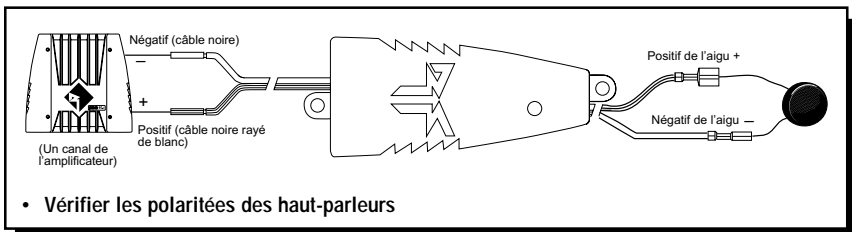

INSTALLATION



Connexion du filtre – fanatic X

Niveau de l'aigu 0dB

Niveau de l'aigu -3dB

(Un canal de l'amplificateur)

- Vérifier les polarités des haut-parleurs
- 0dB Pas d'atténuation de l'aigu par rapport au médium.
- -3dB d'atténuation du niveau de l'aigu -3dB d'atténuation par rapport au médium. (Ex: Idéal pour le positionnement de l'aigu en haut de portière et le médium en bas ou "kick panel" Volume de charge créer en bas de porte ou dans l'angle de celle-ci, au niveau des pieds.)
- Ampoule de protection remplaçable pour tweeter Cette ampoule sert de fusible de protection contre les surcharges. Si l'ampoule brûle, retirez-la et placez-en une neuve (réf. #HDW10932) dans les clips de retenue.

FRANÇAIS

Connexion du filtre – fanatic Q

Niveau de l'aigu 0dB

Niveau de l'aigu -3dB

Niveau de l'aigu -6dB

0° 180°

(Un canal de l'amplificateur)

- Vérifier les polarités des haut-parleurs
- 0dB Pas d'atténuation de l'aigu par rapport au médium.
- -3 ou -6dB d'atténuation de l'aigu -3 ou -6dB de réduction du niveau par rapport au médium. (Ex: Idéal pour le positionnement de l'aigu en haut de portière et le médium en bas ou "kick panel" Volume de charge créer en bas de porte ou dans l'angle de celle-ci, au niveau des pieds.)
- 0°/180° Inversion de phase de l'aigu par rapport au médium. Cette disposition en phase relative est utile quand l'aigu est positionner loin du médium. L'inversion du commutateur de phase
- Ampoule de protection remplaçable pour tweeter Cette ampoule sert de fusible de protection contre les surcharges. Si l'ampoule brûle, retirez-la et placez-en une neuve (réf. #HDW10932) dans les clips de retenue. apportera une modification significative de l'écoute.

Die folgende Bedienungsanleitung soll Ihnen beim Einbau eine Hilfestellung geben.

EINLEITUNG

Diese Bedienungsanleitung enthält Informationen für den Gebrauch und Einbau des Fanatic P, X und Q tweeters. Wir empfehlen, diese auch für Fragen in der Zukunft sorgfältig aufzubewahren.

Es ist empfehlenswert, sich das Fanatic P, X und Q tweeters von einem Autorisierten Rockford Fosgate Fachhändler einbauen zu lassen. Sollten Sie den Einbau jedoch selber vornehmen wollen, so empfehlen wir Ihnen, die Bedienungsanleitung sorgfältig zu lesen.

EINBAUORT

- Für das optimale Zusammenspiel von Mittel- und Hochtöner, sollte der Hochtöner niemals weiter als 5cm vorn Mitteltoner entfernt montiert werden. (Abb. 1)

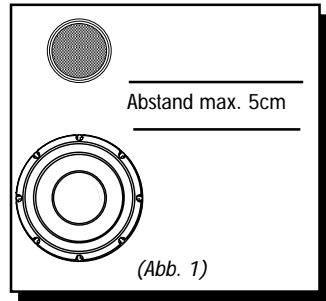

EINBAU

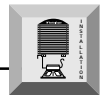

Frequenzweichen Anschlüsse – fanatic P

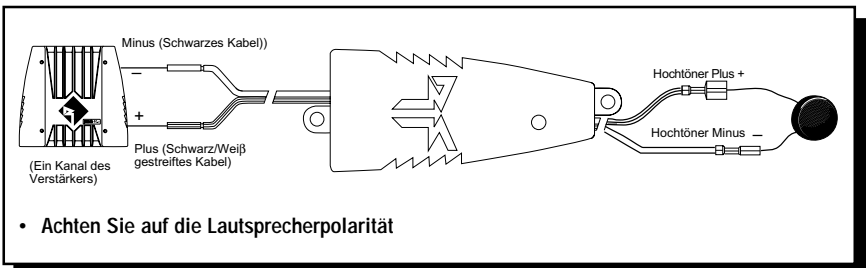

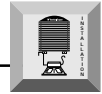

Frequenzweichen Anschlüsse – fanatic X

0dB Hochtonabsenkung

-3dB Hochtonabsenkung

INPUT TWEETER

(Ein Kanal des Verstärkers)

- Achten Sie auf die Lautsprecherpolarität
- 0dB Hochtonabsenkung stimmt mit der Lautstärke mit mitteltönern überein
- -3dB Hochtonabsenkung, reduziert die Lautstärke des Hochtöners gegenüber der Lautstärke des Mitteltöners
-3dB leiser, als der Mitteltöner (Ideal für Einbauten, bei denen die Hochtöner im Armaturenbrett und die Mitteltöner in Fußraum eingesetzt werden)
- Austauschbare Birne zum Schutz des Hochtöners Die Glühbirne dient als Sicherung, um vor Überladung zu schützen. Sollte die Birne ausbrennen, die ausgebrannte Birne entfernen und eine neue Birne (Ersatzteilnr. HDW10932) in den Halterungsclip einführen.

Frequenzweichen Anschlüsse – fanatic Q

0dB Hochtonabsenkung

-3dB Hochtonabsenkung

-6dB Hochtonabsenkung

0° 180°

INPUT TWEETER

(Ein Kanal des Verstärkers)

- Achten Sie auf die Lautsprecherpolarität
- 0dB Hochtonabsenkung stimmt mit der Lautstärke mit mitteltönern überein
- -3dB/-6dB Hochtonabsenkung, reduziert die Lautstärke des Hochtöners um -3dB lder - 6dB gegenüber der Lautstärke Mitteltöners (Ideal für Einbauten, bei denen die Hochtöner im Armaturenbrett und die Mitteltöner in Fußraum eingesetzt werden)
- 0°/180° Phasenkorrektur, ändert die Phase (Ideal, wenn der Hochtöner weit entfernt vom Mitteltöner eingebaut wird). Schieben Sie den Schalter in die Position, bei der sich die beste Soundqualität einstellt.
- Austauschbare Birne zum Schutz des Hochtöners Die Glühbirne dient als Sicherung, um vor Überladung zu schützen. Sollte die Birne ausbrennen, die ausgebrannte Birne entfernen und eine neue Birne (Ersatzteilnr. HDW10932) in den Halterungsclip einführen.

DEUTSCH

Leggere le istruzioni seguenti prima dell'installazione del prodotto.

INTRODUZIONE

Questo manuale fornisce informazioni sulle caratteristiche e sul installazione dei tweeters Fanatic P, X e Q. Vi suggeriamo di conservare questo manuale come riferimento futuro.

Raccomandiamo fortemente che il tweeter sia installato dal vostro rivenditore Rockford Fosgate. Se scegliete di procedere con l'installazione da soli, leggete attentamente tutto il manuale prima di proseguire.

POSIZIONAMENTO

- Per ottenere la miglior integrazione tra tweeter e midrange, vi suggeriamo di posizionare i due componenti a meno di 5 cm tra loro. (Figura 1)

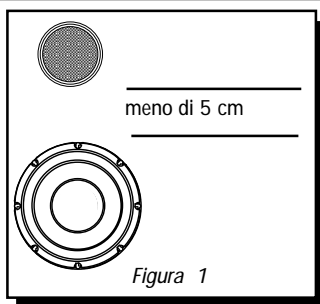

INSTALLAZIONE



Connessioni del crossover – fanatic P

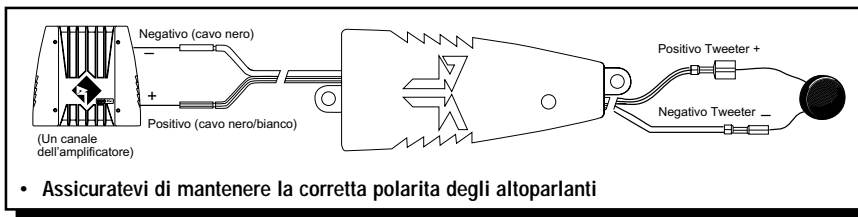



Connessioni del crossover – fanatic X

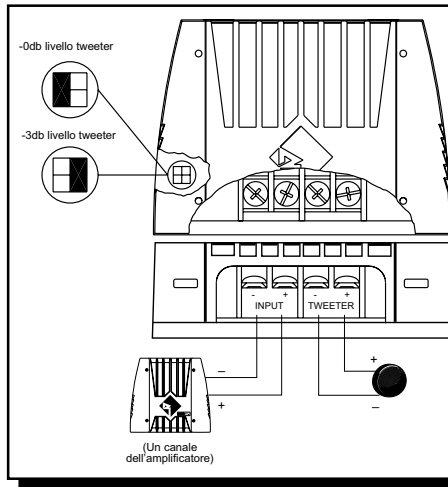

- Assicuratevi di mantenere la corretta polarità degli altoparlanti
- 0dB di livello del tweeter accoppia la sensibilità del midrange a quella del tweeter
- -3dB di livello del tweeter riduce l'efficienza del tweeter -3dB (meno del midrange (es.: ideale per tweeter posizionati nella parte alta delle portiere e midrange molto bassi nelle tasche))
- Lampadina di protezione tweeter La lampadina funge da fusibile di protezione contro i sovraccarichi. Se la lampadina si rompe, toglierla e inserirne una nuova (codice n.HDW10932) nei fermi.

Connessioni del crossover – fanatic Q

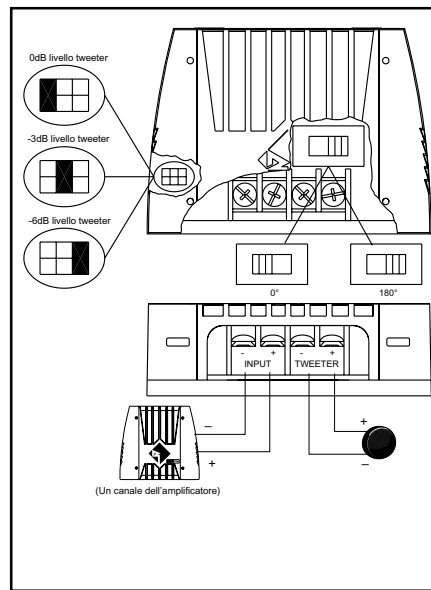

- Assicuratevi di mantenere la corretta polarità degli altoparlanti
- 0dB di livello del tweeter accoppia la sensibilità del midrange a quella del tweeter
- -3dB/-6dB di livello del tweeter per abbassarne l'efficienza di 3dB o 6dB rispetto al midrange (es.: ideale per tweeter posizionati nella parte alta delle portiere e midrange molto bassi nelle tasche)
- La fase del tweeter a 0/180° ne accoppia la corretta fase al midrange (tipicamente quando i due componenti sono lontani tra loro). Posizionate l'interruttore nella posizione a cui corrisponde il miglior suono.
- Lampadina di protezione tweeter La lampadina funge da fusibile di protezione contro i sovraccarichi. Se la lampadina si rompe, toglierla e inserirne una nuova (codice n.HDW10932) nei fermi.

MADE IN CHINA

This product is designed, developed and assembled in the USA by a dedicated group of American workers. The majority of the components used in the construction of this product are produced by American companies. However, due to the global nature of their manufacturing facilities and the loudspeaker parts industry in general, some parts may be manufactured in other countries.

Rockford Fosgate

Rockford Corporation

546 South Rockford Drive

Tempe, Arizona 85281 U.S.A.

In U.S.A., (480) 967-3565

In Europe, Fax (49) 8503-934014

In Japan, Fax (81) 559-79-1265

www.rockfordfosgate.com