



RF-2.9x

Installation Reference Sheet
Páginas de Referencia para la Instalación
Schéma d'Installation
Installations Beiblatt
Istruzioni di Installation



Dear Customer,

Congratulations on your purchase of the world's finest brand of car audio electronics. At Rockford Fosgate we are fanatics about musical reproduction at its best, and we are pleased you chose our product. Through years of engineering expertise, hand craftsmanship and critical testing procedures, we have created a wide range of products that reproduce music with all the clarity and richness you deserve.

For maximum performance we recommend you have your new Rockford Fosgate product installed by an Authorized Rockford Fosgate Dealer, as we provide specialized training through Rockford Technical Training Institute (RTTI). Please read your warranty and retain your receipt and original carton for possible future use.

Great product and competent installations are only a piece of the puzzle when it comes to your system. Make sure that your installer is using 100% authentic installation accessories from Connecting Punch in your installation. Connecting Punch has everything from RCA cables and speaker wire to Power line and battery connectors. Insist on it! After all, your new system deserves nothing but the best.

To add the finishing touch to your new fanatic image order your Rockford Fosgate wearables, which include everything from T-shirts and jackets to hats and sunglasses.

To get a free brochure on Rockford Fosgate products and Rockford wearables, please call 602-967-3565 or FAX 602-967-8132. For International orders, FAX +001-1-602-967-8132 or call +001-1-602-967-3565.

PRACTICE SAFE SOUND™

CONTINUOUS EXPOSURE TO SOUND PRESSURE LEVELS OVER 100dB MAY CAUSE PERMANENT HEARING LOSS.

HIGH POWERED AUTOSOUND SYSTEMS MAY PRODUCE SOUND PRESSURE LEVELS WELL OVER 130dB. USE

COMMON SENSE AND PRACTICE SAFE SOUND.

If, after reading your manual, you still have questions regarding this product, we recommend that you see your Rockford Fosgate dealer. If you need further assistance, you can call us direct at 1-800-795-2385. Be sure to have your serial number, model number and date of purchase available when you call.

The serial number can be found on the outside of the box. Please record it in the space provided below as your permanent record. This will serve as verification of your factory warranty and may become useful in recovering your amplifier if it is ever stolen.

Serial Number: _____

Model Number: _____

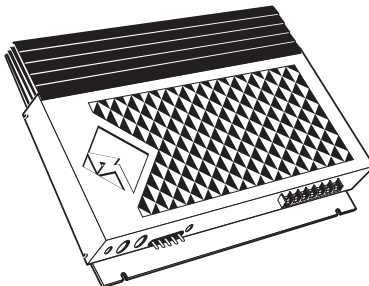

FEATURES

TECHNICAL FEATURES

- **Trans•ana** – Sound quality topology that sends an extended bandwidth accurately to the output stages of the amplifier
- **TOPAZ** – Eliminates troublesome group loop noise between the source and amplifier
- **NOMAD** – Extremely fast protection system that always protects the amplifier and never degrades the sound
- **MOSFET Devices** – Power supply and output devices that have high thermal stability, fast switching speed, low output impedance, and wide bandwidth linearity
- **DSM (Discrete Surface Mount) Technology** – Fewer connections, improved reliability, shorter signal paths, superior signal-to-noise ratio and awesome sonic performance
- **High Level Inputs** – Allows wide compatibility with factory and aftermarket source units. Accepts 1/8" female spade lugs
- **Input Sensitivity Control** – Level control can be adjusted to match output levels from a variety of source units
- **Gold-Plated Power/Speaker Barrier Strip** – Screw terminals accept #10 spade lugs or bare wire sized from 10 to 18 AWG
- **XCard Crossover** – Configurable for a multitude of operating frequencies. The orientation of the card in its socket determines its function of high-pass, low-pass or full range operation
- **Bass EQ** – The Bass EQ allows a narrow band adjustment of up to +18dB centered at 45Hz. The bass boost can be bypassed by turning the control to its minimum or counterclockwise position.

DESIGN FEATURES

- **Extruded Heatsink** – Dissipates heat generated by the amplifier's circuitry

- **LED Power Indicator** – Visual indicator illuminates when amplifier is turned on

WARRANTY

- 3 Years

SPECIFICATIONS

RMS Continuous Power @ 14.4V (Competition Standard)

Stereo into a 4Ω load (20Hz-20kHz, <0.10% THD) 45x2
 Stereo into a 2Ω load (20Hz-20kHz, <0.30% THD) 90x2
 Bridged into a 4Ω load (20Hz-20kHz, <0.30% THD) 180x1

Dynamic Power @ 14.4V (IHF Standard)

Stereo into a 4Ω load (20Hz-20kHz, 1% THD) 75x2
 Stereo into a 2Ω load (20Hz-20kHz, 1% THD) 110x2
 Bridged into a 4Ω load (20Hz-20kHz, 1% THD) 220x1

Signal-to-Noise Ratio >100dB (A-weighted)
 Frequency Response 20Hz-20kHz ±0.5dB
 Bandwidth 10Hz-250kHz ±3.0dB
 Damping Factor @ 4Ω >200 (at output connector)

Slew Rate 30V/μs
 IM Distortion (IHF) <0.05%
 Input Impedance 20kΩ
 Factory Default Crossover Frequency 80Hz adjustable
 Crossover Slope 12dB/octave Butterworth
 Source Unit Compatibility (+15dB gain overlap) 250mV to 15V
 (low level input)
 Input Sensitivity (+0dB gain overlap) .. 250mV to 4V (low level input)
 650mV to 11V (high level input)
 Operating Voltage +9V to +15.4V DC
 External Battery Fuse 30A (ATC)
 Standby Current 800mA
 Dimensions 2"H x 8⁵/₁₆"W x 10⁷/₈"L
 (5.08mm x 20.63mm x 26.27mm)
 Weight 4.1 lbs. (1.86kg)

ACCESSORY PACK

(1) 3/32" Allen Wrench (1) ATC In-line Fuseholder (1) ATC 30 Amp Fuse



Specifications subject to change without notice

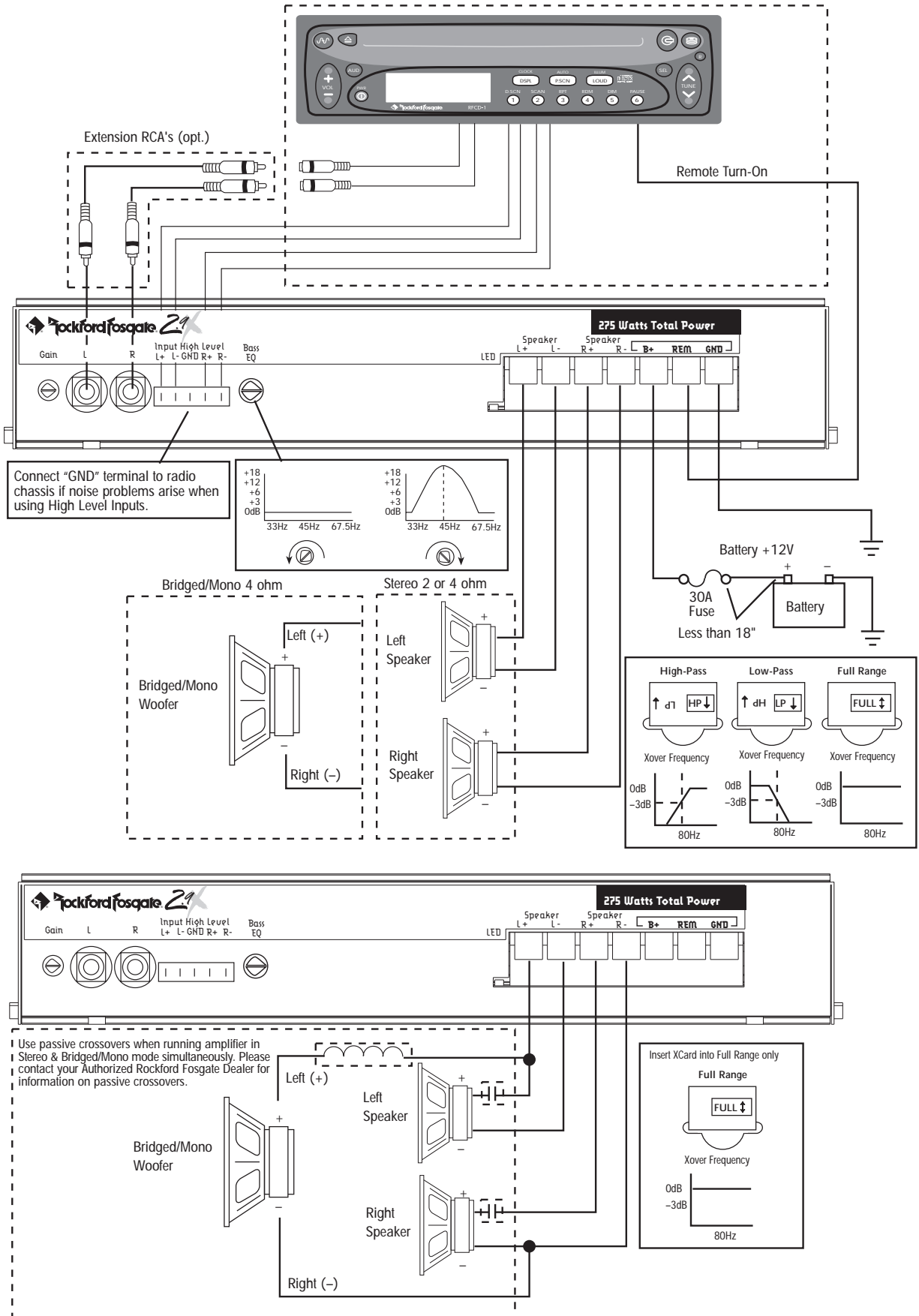

INSTALLATION

- For safety, disconnect the negative lead from the car battery prior to beginning the installation

Trunk Mounting

Mounting the amplifier vertically on a surface with the fin grooves running up and down will provide the best cooling for the amplifier.

Passenger Compartment Mounting

Mounting the amplifier in the passenger compartment will work as long as you provide a sufficient amount of air for the amplifier to cool itself. If you are going to mount the amplifier under the seat of the vehicle, you must have at least 1" (2.54cm) of air gap around the amplifier's heatsink.

B+ Terminal

The B+ cable MUST be fused 18" (45cm) or less from the vehicle's battery. Prepare the cable ends and install the fuseholder under the hood. Connections should be water tight.

GND Terminal

Prepare a length of cable to be used for the ground connection. Prepare the chassis ground by scraping any paint from the metal surface and thoroughly clean the area of all dirt and grease. Fasten the cable to the chassis using a screw.

REM Terminal

Connect the REM wire to a switched 12 volt positive source. The switched signal is usually taken from the source unit's auto antenna or the accessory lead. If the source unit does not have these outputs available, the recommended solution is to wire a mechanical switch in-line with a 12 volt source to activate the amplifier.

Input Connectors

Follow the diagram and connect the appropriate signal cables to the input terminals of the amplifier. Be sure that the signal cables are routed close together and away from any high current wires.

Speaker Output Terminals

Connect the speaker system to the amplifier by inserting the wires into the corresponding output terminals and tighten the set screws. Follow the diagram for proper signal polarity. **DO NOT chassis ground any of the speaker wires as unstable amplifier operation may result. CAUTION: This amplifier is not recommended for impedance loads below 2Ω stereo and/or 4Ω bridged (mono).**

Gain Control(s)

The amplifier is factory set for optimum dynamic range with a 500mV input signal. The system levels may be adjusted by ear when using a source unit with higher or lower output levels by using the following procedure.

1. Turn the gain control to minimum (counterclockwise)
2. Play a music track with high dynamic content and turn up the source unit to at least 3/4 volume
3. Slowly increase the gain and set it just below audible distortion or until reaching a comfortable hearing threshold (whichever occurs first)

TROUBLESHOOTING

Symptom	Diagnosis	Remedy
Amplifier does not turn on	B+ or REM not between 10.5 and 15.5 volts or no voltage present	Check the alternator, battery, fuse, and wiring and repair as necessary
	Amplifier is not properly grounded	Check wiring and repair as necessary
Amplifier has no output	XCard is missing or not inserted properly into slot	Check XCard installation and repair as necessary
Amplifier Noise (Turn-On Pop)	Voltage spike from source unit is entering amplifier's input	Connect turn-on module to REM terminal if pops are eliminated with no input signal to amplifier
Engine Noise	Noise is radiating into signal cables	Re-route signal cables away from sources of high current

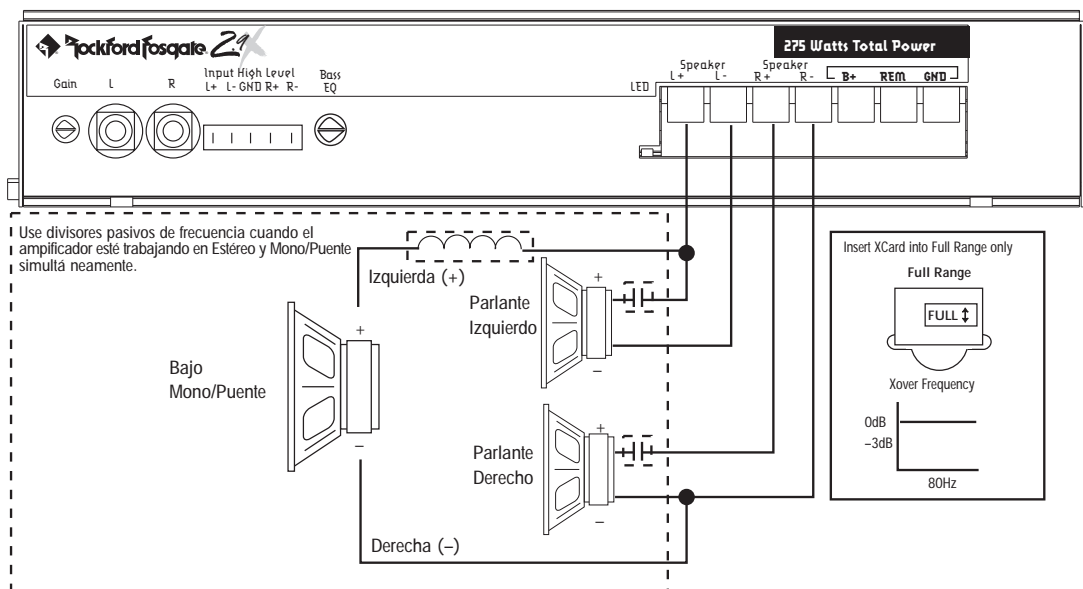
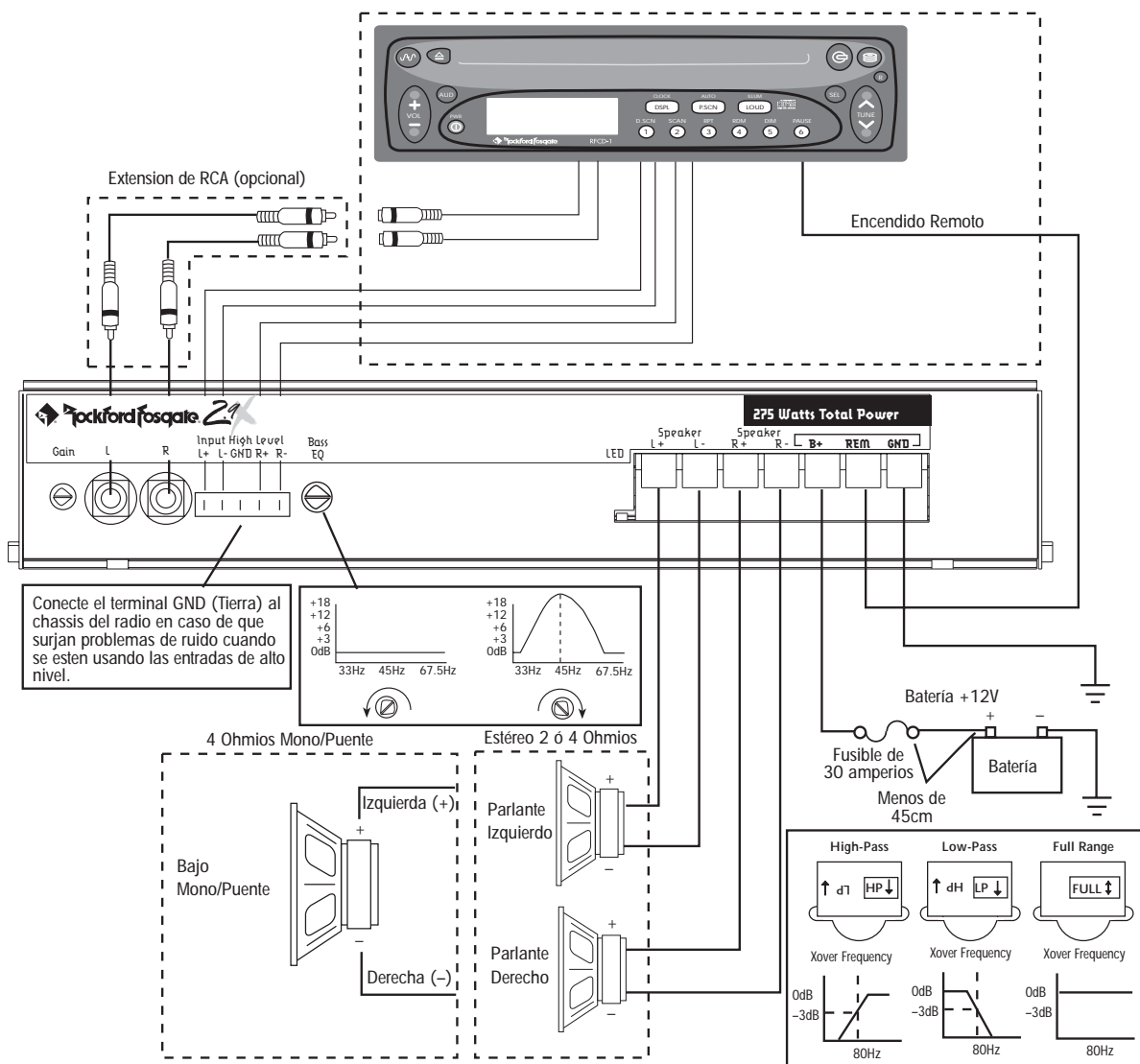

INSTALACIÓN

- Por seguridad, desconecte el terminal negativo de la batería antes de comenzar la instalación.

Montaje en el Malatero del vehículo

Monte el amplificador verticalmente con las líneas del radiador orientadas de arriba hacia abajo. De esta manera conseguirá la mejor ventilación.

Montaje en el Compartimento de Pasajeros

El montaje en el compartimento de pasajeros será eficiente en función de la ventilación que tenga el amplificador. Si va a instalar el amplificador bajo un asiento deberá dejar al menos 2.5cm libres sobre la carcasa del amplificador.

Terminal B+

El cable B+ debe ir provisto de un fusible a una distancia no mayor de 45cm de la batería. Prepare el cable e instale el portafusibles en el compartimento del motor. Las conexiones han de ser impermeables.

Terminal GND

Prepare un trozo de cable para usarlo como toma de masa. Prepare un punto de masa en el chasis rascando y eliminando la pintura de la superficie de metal y límpielo de toda suciedad asegure el cable al chasis con un tornillo.

Terminal REM (Encendido remoto)

Conecte el cable REM a un punto de +12V conmutable. La señal se suele coger de la salida auto antena del radio cassette si este no tiene salida remote.

Conectores de Entrada

Siga el diagrama y conecte los cables adecuados para señal a los terminales de entrada del amplificador. Asegúrese de que los cables de señal estén canalizados en conjunto y lo más lejos posible de cualquier cable de alto amperaje.

Terminales de salida para los Parlantes

Conecte el sistema de parlantes al amplificador insertando los cables correspondientes en los terminales de salida y luego aprete los tornillos. Siga el diagrama para una adecuada polaridad de señal. **NO CONECTE ninguno de los cables de los parlantes a la masa de la carcasa, ya que esto puede resultar en una operación inestable del amplificador. PRECAUCION: este amplificador no está recomendado para cargas de impedancia por abajo de 2 Ohmios en estéreo y/ó 4 Ohmios en modo puente (bridge mono).**

Control(es) de Ganancia

El amplificador está dispuesto desde la fábrica para óptimo rango dinámico con una señal de entrada de 500mV. Los niveles del sistema pueden ser ajustado por oído cuando se utilice una unidad fuente con niveles de salidas más altos ó bajos, mediante el uso del siguiente procedimiento:

1. Lleve el control de ganancia al mínimo (en contra de las agujas del reloj)
2. Reproduzca una pista musical con alto contenido dinámico y lleve el volumen de la unidad fuente hasta unos 3/4 de máximo
3. Lentamente incremente la ganancia y pare justo bajo el nivel audible de distorsión ó hasta que llegue a un umbral agradable de audición (cualquiera que ocurra primero)

BÚSQUEDA DE FALLAS

Síntoma	Diagnóstico	Remedio Reparación
El Amplificador no enciende	B+ ó REM no están entre 10.5 y 15.5 voltios ó no hay voltaje presente.	Chequee el alternador, batería, fusible y cableado y repare según sea necesario
	El amplificador no está aterrado apropiadamente	Cheque el cableado y repare según sea necesario
El amplificador no tiene salida	La XCard no se encuentra o no está insertada apropiadamente en la ranura	Chequee la instalación de la XCard y repare según sea necesario
Ruido de Amplificador (Popeo de encendido)	Picos de voltaje de la unidad fuente están presentes en la entrada del amplificador	Conecte el módulo de encendido al terminal REM si el popeo es eliminado cuando el amplificador no tiene señal de entrada
Ruido de Motor	Ruido está siendo radiado en los cables de señal	Recanalizar los cables de señal alejado de fuentes de alto amperaje

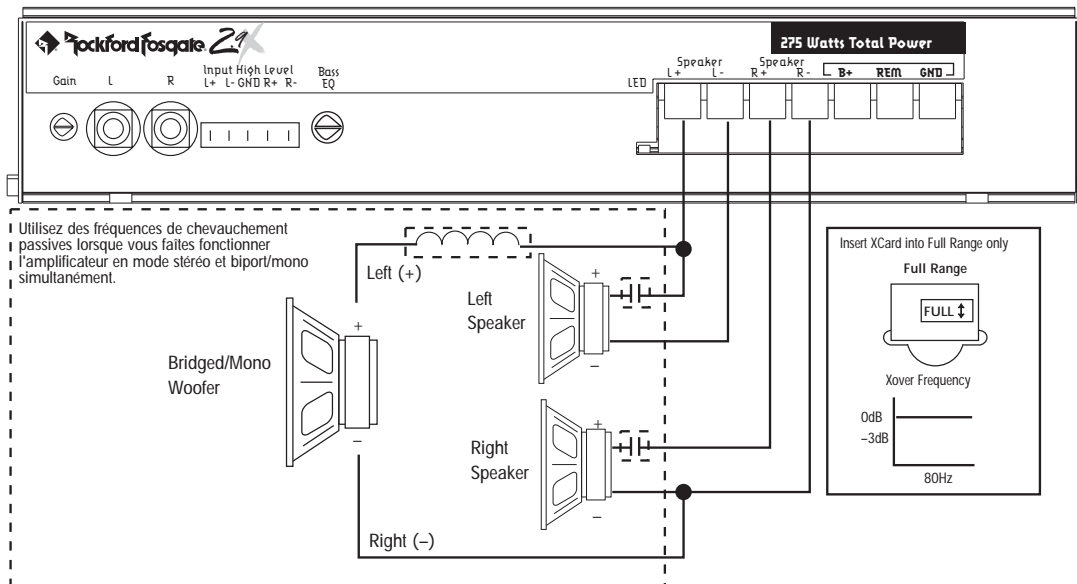
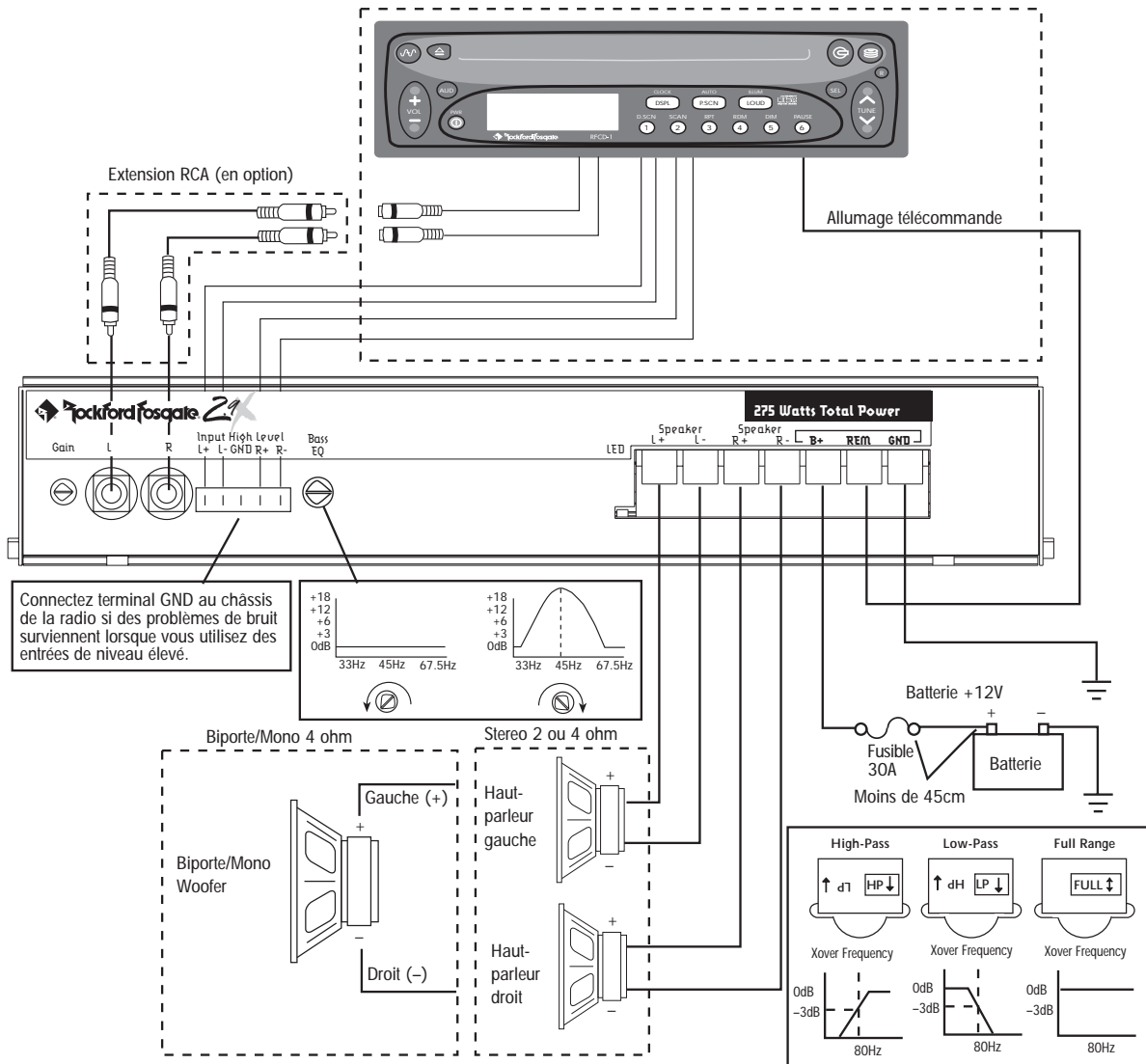

INSTALLATION

- Pour votre sécurité, déconnectez la borne négative de la batterie du véhicule avant de commencer l'installation.

Montage dans l'habitacle

Monte el amplificador verticalmente con las lineas del radiador orientadas de arriba hacia abajo. De esta manera conseguira la mejor ventilacion.

Montaje en el Compartimento de Pasajeros

Monter l'amplificateur dans l'habitacle ne pose aucun problème, du moment qu'il y ait assez d'air pour le refroidir. Si vous montez l'ampli en dessous du siège, prévoyez 3 cm d'air autour du radiateur.

Terminal B+

Il est impératif qu'il y ait un fusible sur le câble pour la connexion à la masse. Préparez le châssis en grattant la peinture de la surface métallique et nettoyez la saleté et l'huile. Attachez le câble au châssis avec une vis.

Terminal GND

Préparez une longueur de câble pour la connexion à la masse. Préparez le châssis en grattant la peinture de la surface métallique et nettoyez la saleté et l'huile. Attachez le câble au châssis avec une vis.

Terminal REM

Connectez le fil REM à une commande 12 volts positive de la source. La commande 12 volts est habituellement prise sur la sortie antenne électrique de la source ou la commande accessoire. Si la source ne dispose pas de ces sorties, nous vous recommandons d'installer un interrupteur qui fournira un positif 12 volts au REM de l'amplificateur.

Connecteurs d'entrée

Suivez le diagramme et connectez les câbles de signalisation appropriés aux terminaux d'entrée de l'amplificateur. Assurez-vous que les câbles de signalisation sont bien acheminés à proximité les uns des autres et suffisamment éloignés de fils électriques à haute intensité.

Terminaux de sortie du haut-parleur

Connectez les haut-parleurs à l'amplificateur en introduisant les fils dans les terminaux de sortie correspondant et en serrant les vis e calage. Suivez le diagramme pour trouver la bonne polarité de signalisation NE mettez à la terre, au châssis, AUCUN des fils du haut-parleur car cela risquerait d'entraîner un fonctionnement instable de l'amplificateur.

ATTENTION: cet amplificateur n'est pas recommandé pour des charges d'impédance inférieures à 2 stéréo et/ou 4 biporte (mono).

Réglage(s) du gain

L'amplificateur a été réglé en usine pour une gamme optimum de variations de volume avec une signalisation d'entrée de 500mV. Vous pouvez ajuster, à l'oreille, les niveaux du système, lorsque vous utilisez une unité de source dotée de niveaux de rendement de sortie inférieurs ou supérieurs par le biais de la procédure suivante.

1. Réglez le gain sur le minimum (dans le sens contraire des aiguilles d'une montre)
2. Choisissez un morceau de musique comprenant une gamme élevée de variations de volume et réglez le volume de l'unité de source jusqu'à trois quart, au moins, du volume possible
3. Augmentez doucement le gain et réglez-le juste en-dessous d'une distorsion perceptible à l'oreille ou jusqu'à l'atteinte d'un seuil d'écoute agréable (selon ce qui est atteint en premier)

TROUBLESHOOTING

Symptom	Diagnosis	Remedy
L'amplificateur ne s'allume pas	B+ ou REM ne tombe pas entre 10.5 et 15.5 volts ou pas de voltage	Vérifiez l'alternateur, la batterie, les fusibles, la disposition des câbles, et effectuez des réparations si cela s'avère nécessaire
	L'amplificateur n'est pas correctement mis à la terre.	Vérifiez la disposition des câbles, et effectuez des réparations si cela s'avère nécessaire
L'amplificateur n'a pas de rendement de sortie	L'XCard manque ou bien n'a pas été correctement introduite dans la fente	Vérifiez l'installation de l'XCard, et effectuez des réparations si cela s'avère nécessaire
Parasites amplificateur (Allumage parasite)	La crête de tension de voltage sortant de l'unité de source pénètre l'entrée de l'amplificateur	Connectez le module d'établissement du contact au terminal REM si des parasites sont éliminés sans signalisation d'entrée à l'amplificateur
Bruit du moteur	Des parasites rayonnent dans les câbles de signalisation	Acheminez de nouveau les câbles de signalisation en les éloignant de sources de courant à haute intensité. L'amplificateur n'a pas de rendement de sortie

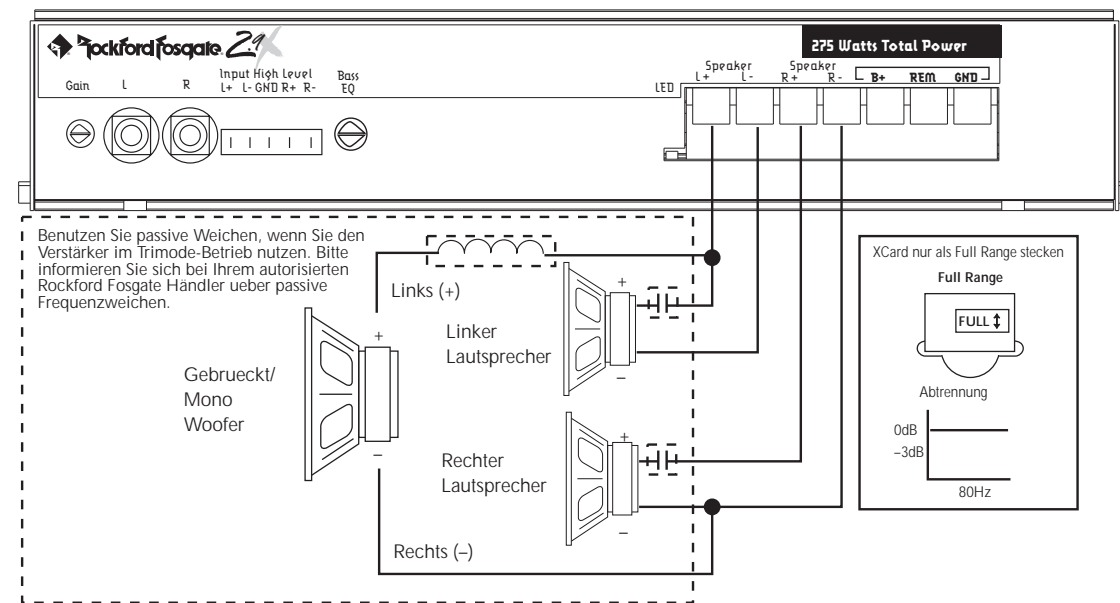
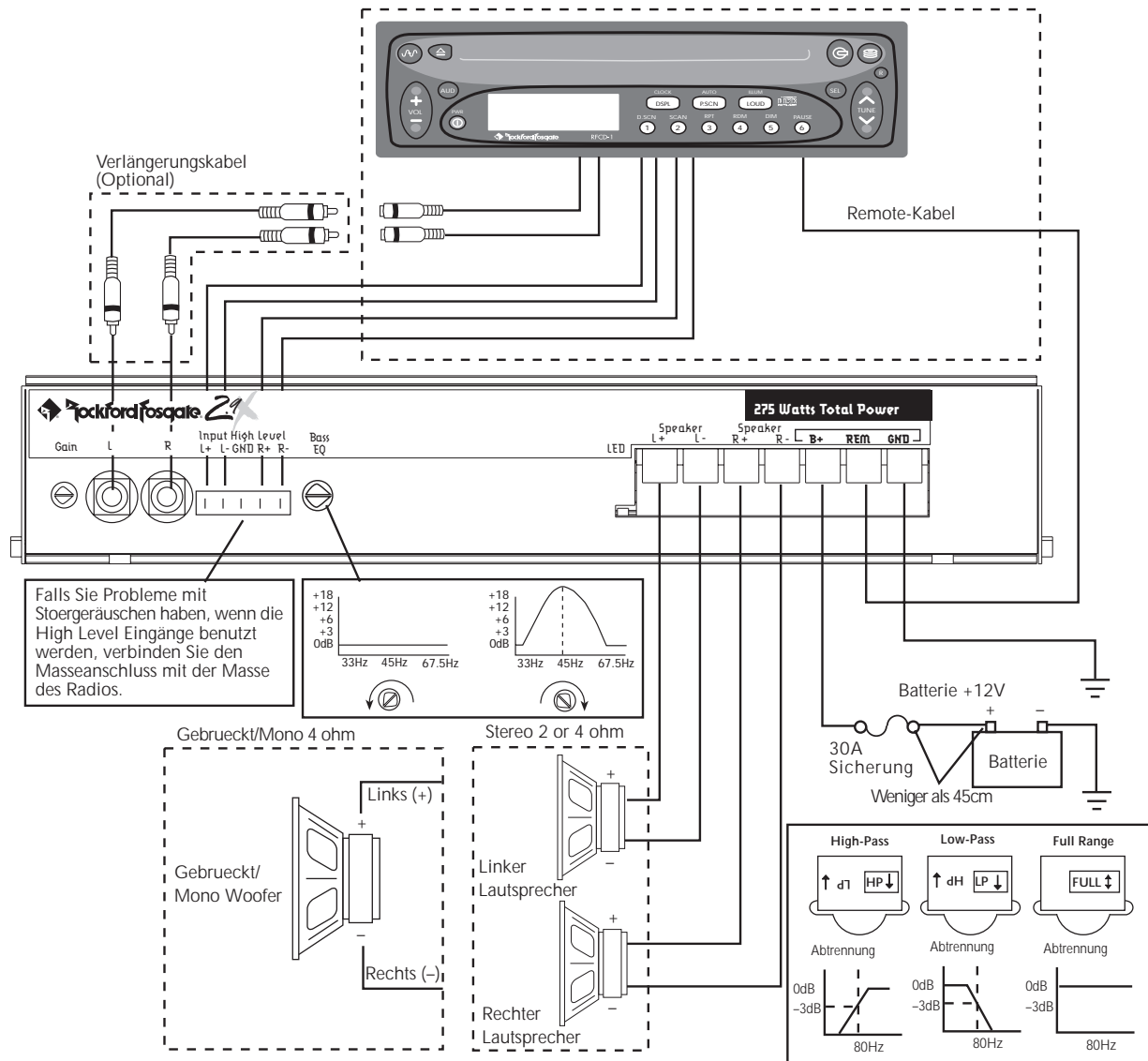

EINBAU

- Zur Sicherheit klemmen Sie den **Negativ-Pol** der Batterie während des gesamten Einbaues ab.

Im Fahrzeugkofferraum

Der vertikale Einbau der Endstufen, das bedeutet, daß die Kühlrippen von oben nach unten verlaufen, gibt dem Verstärker die beste Kühlung.

Auf der Beifahrerseite

Sollte der Verstärker auf der Beifahrerseite montiert werden, so ist es sehr wichtig für eine ausreichende Kühlung zu sorgen. Sollte der Verstärker z.B. unter dem Beifahrersitz montiert werden, sollte dem Kühlkörper mindestens ein Luftspalt von 3 cm bleiben, um so für eine ausreichende Kühlung zu sorgen.

B+ Anschluß

Die Plus-Leitung MUß ca. 40 cm nach dem Plus-Pol der Batterie abgesichert sein. Preparieren Sie die Kabellängen und montieren Sie den Sicherungshalter im Motorraum. ALLE Verbindungen müssen wasserdicht sein.

GND Anschluß

Preparieren Sie Ihr Kabel für die negativ Leitung (Erdung). Preparieren Sie die Anschlußstelle des Erdungskabels, indem Sie das Metall gründlich reinigen und vom Lack befreien. Befestigen Sie nun die Erdung an dieser Stelle mit einer Schraube.

REM Anschluß

Verbinden Sie das Ein- und Ausschaltungskontroll-Kabel mit Ihrem Radio (12 Volt positiv). Normalerweise verwenden Sie hierfür die Ant.-Remote. Sollte Ihr Radio diesen Anschluß nicht besitzen, so verwenden Sie eine 12 Volt Spannung, die Sie durch einen Schalter ein- und ausschalten können.

Eingangs-Anschlüsse

Beachten Sie den Anschlussplan und verbinden Sie die Signalkabel mit den Eingangs-Anschlüssen des Verstärkers. Seien Sie sicher, daß die Kabel dicht zusammen und entfernt von stromführenden Kabeln liegen.

Lautsprecher Ausgänge

Verbinden Sie das Lautsprechersystem mit dem Verstärker, indem Sie die Kabel in die entsprechenden Anschlüsse stecken und verschrauben. Beachten Sie hierbei den Anschlussplan, um eine korrekte Polarität zu gewährleisten. **Erden Sie niemals eine der Lautsprecherleitung auf die Masse des Fahrzeuges. Achtung: Die minimale Last von 2Ω Stereo und/oder 4Ω gebrückt (Mono) darf nicht unterschritten werden.**

Eingangsempfindlichkeit

Der Verstärker ist Werksseitig auf eine Eingangsspannung von 500mV eingestellt. Die Eingangsempfindlichkeit kann nach Gehör verstellt werden, wenn die Ausgangsspannung des Steuergerätes höher oder niedriger ist. Gehen Sie wie folgt vor.

1. Drehen Sie die Eingangsempfindlichkeit auf ein Minimum (gegen den Uhrzeigersinn).
2. Spielen Sie einen Musiktitel mit einer sehr hohen Dynamik und drehen Sie die Lautstärkekontrolle des Steuergerätes auf 3/4 der Maximallautstärke.
3. Jetzt verstellen Sie die Eingangsempfindlichkeit des Verstärkers soweit (im Uhrzeigersinn drehen), bis Sie eine Verzerrung des Signals wahrnehmen. Danach sollte die Empfindlichkeit wieder soweit zurück gedreht werden (gegen den Uhrzeigersinn), bis die Verzerrungen verschwinden.

FEHLERSUCHE

Syptom	Diagnose	Fehlerbehebung
Verstärker schaltet nicht ein	Die B+ oder Rem. Spannung liegt nicht zwischen 10.5 und 15.5 Volt	Kontrollieren Sie die Lichtmaschine, Batterie, Sicherung und die Kabel. Reparieren Sie diese, wenn nötig
	Verstärker ist nicht korrekt geerdet	Kontrollieren Sie die Kabel und reparieren Sie diese, wenn nötig
Verstärker hat keine Ausgangsleistung	Die XCard ist falsch oder gar nicht in den entsprechenden Sockel gesteckt.	Kontrollieren Sie die Installation der XCard und ändern Sie diese, wenn nötig
Verstärker Einschaltgeräusch (Turn-On Pop)	Spannungsspitze des Steuergerätes erreicht den Verstärker	Verbinden Sie ein Turn-on Modul mit dem Rem. Terminal, wenn die Geräusche eliminiert sind, sobald kein Signal am Verstärker anliegt.
Lichtmaschinen Summen	Störungen strahlen in die Signalkabel	Verlegen Sie die Kabel weit entfernt von stromführenden Kabeln

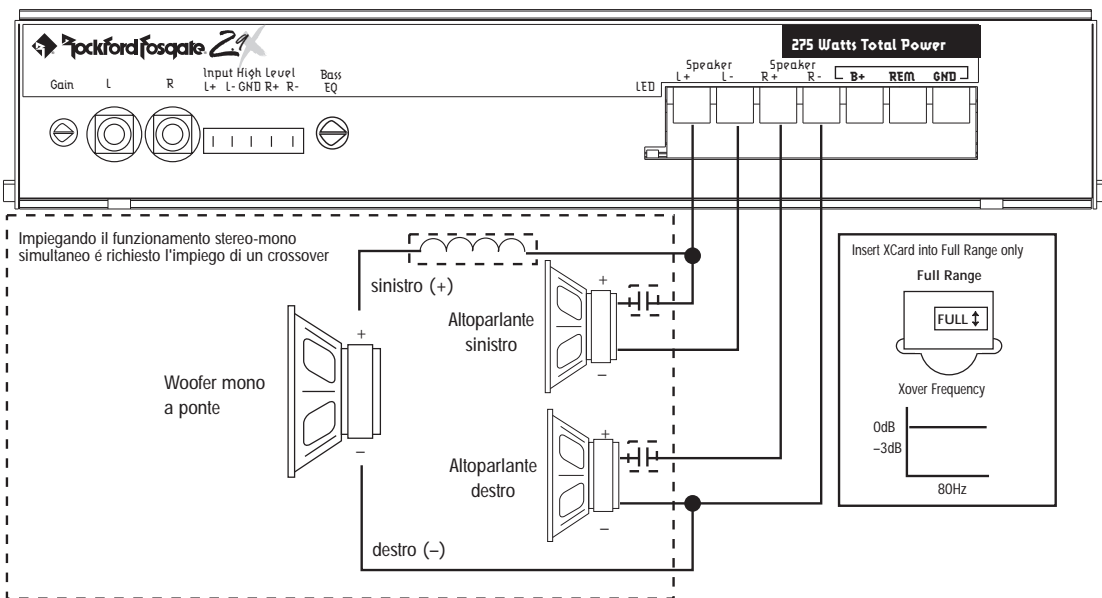
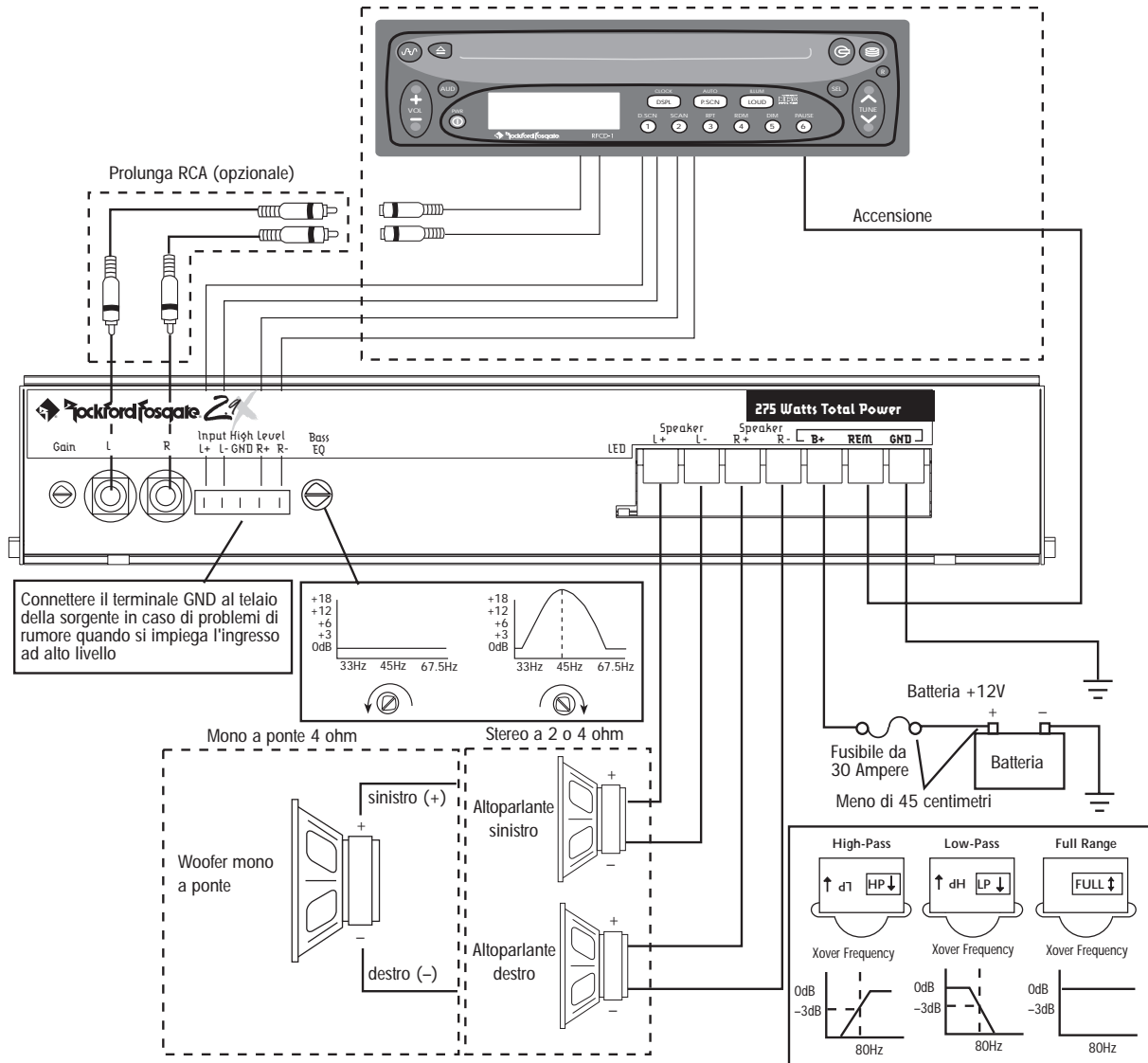

INSTALLAZIONE

- Per sicurezza, scollegare il polo negativo della batteria dell'auto prima di iniziare l'installazione.

Nel Bagagliaio

Montando l'amplificatore su una superficie in verticale con le alette direzionate dall'alto verso il basso si garantirà un miglior raffreddamento dell'amplificatore.

Nel'abitacolo

Montare l'amplificatore nell'abitacolo si avrà un funzionamento regolare se si garantisce un flusso d'aria sufficiente. Per l'installazione sotto un sedile, è necessario avere uno spazio di almeno 3 cm attorno a tutto l'amplificatore.

Terminale B+ (cavo positivo)

Il cavo positivo deve essere protetto da un fusibile a non più di 45 cm dalla batteria. Terminare il cavo e installare il fusibile nel vano motore. Tutte le connessioni devono essere a prova d'acqua.

Terminal GND (cavo negativo)

Decidere la lunghezza del cavo e terminarlo. Preparare la massa grattando la vernice dal telaio dell'auto ed eliminando tracce di olio o sporco. Fissare il cavo di massa al telaio con una vite.

Terminal REM (Consenso di accensione)

Collegare il cavo REM ad un positivo presente solo ad autoradio accesa (normalmente il cavo pilota dell'antenna elettrica o il cavo accessori dell'autoradio). Se la sorgente non dovesse essere equipaggiata con queste uscite, la soluzione raccomandabile è di inserire un interruttore su un cavo positivo e connettersi all'amplificatore.

Connettori di ingresso

Seguendo lo schema collegate i cavi di segnale agli appropriati terminali di ingresso dell'amplificatore. Assicuratevi che i cavi di segnale siano passati vicini tra loro e lontano da cavi ad alta corrente.

Connettori degli altoparlanti

Collegate il sistema di altoparlanti inserendo i cavi nei terminali corrispondenti e serrate le viti. Seguite lo schema per l'ottimale collegamento delle polarità. **Non cortocircuitate a massa nessun cavo degli altoparlanti, potrebbe verificarsi un anomalo comportamento dell'amplificatore. ATTENZIONE; questo amplificatore non è raccomandato per impedenze inferiori ai 2 ohm stereo w/o 4 ohm mono a ponte.**

Controlli della sensibilità

L'amplificatore è regolato dalla casa per un ottimale rendimento dinamico con segnale di ingresso di 500 mV. Il livello di ingresso può essere regolato anche ad orecchio quando si impiega una sorgente con uscita superiore od inferiore. Seguite questa procedura:

1. Portate il controllo della sensibilità al minimo (senso antiorario)
2. Suonate un brano musicale con elevato contenuto dinamico portando il volume della sorgente a circa 3/4
3. Aumentate lentamente il livello di ingresso dell'amplificatore e posizionate subito prima dell'insorgere di distorsione o quando il livello generale vi appaia confortevole

RISOLUZIONE DEI PROBLEMI

Sintomo	Diagnosi	Rimedio
L'amplificatore non si accende	Il B+ o il REM non hanno una tensione compresa tra i 10,5 e 15,5 volt o nessuna tensione è presente	Verificate l'alternatore, la batteria, i fusibili, il cablaggio e riparate quanto necessario
	L'amplificatore non è correttamente a massa	Controllate il cablaggio e riparate se necessario
Non esce nessun suono	La Xcard non è inserita correttamente o manca	Verificate l'installazione della xcard e riparate se necessario
Rumore dell'amplificatore (bump di accensione)	Picchi di tensione provenienti dalla sorgente entrano dall'ingresso dell'amplificatore	Se il bump si elimina disconnettendo gli ingressi, collegate un modulo di accensione
Rumore dal motore	Il rumore si propaga nei cavi di segnale	Ristendete i cavi di segnale lontano da cavi ad alta corrente

ENGLISH

Please contact your local Authorized
Rockford Fosgate Dealer for information
on Warranty Policies and Technical Support.

ESPAÑOL

Por favor contacte al Distribuidor Autorizado Rockford
Fosgate en su localidad para información sobre Políticas
de Garantía Soporte Técnico.

FRANÇAIS

Veuillez contacter votre distributeur Rockford Fosgate
agréé pour toute information concernant les
modalités de garantie et le support technique.

DEUTSCH

Bitte Fragen Sie Ihren autorisierten Rockford Fosgate
Händler über Informationen, die die Garantie oder
technische Probleme betreffen.

ITALIANO

Contattate il vostro rivenditore autorizzato Rockford
Fosgate per informazioni sulle condizioni di garanzia
e per il supporto tecnico.

LIMITED WARRANTY INFORMATION

Rockford Corporation offers a limited warranty on Rockford Fosgate products on the following terms:

- **Length of Warranty**

3 years on electronics

2 years on source units

90 days on electronic B-stock (receipt required)

30 days on speaker B-stock (receipt required)

- **What is Covered**

This warranty applies only to Rockford Fosgate products sold to consumers by Authorized Rockford Fosgate Dealers in the United States of America or its possessions. Product purchased by consumers from an Authorized Rockford Fosgate Dealer in another country are covered only by that country's Distributor and not by Rockford Corporation.

- **Who is Covered**

This warranty covers only the original purchaser of Rockford product purchased from an Authorized Rockford Fosgate Dealer in the United States. In order to receive service, the purchaser must provide Rockford with a copy of the receipt stating the customer name, dealer name, product purchased and date of purchase.

- **Products found to be defective during the warranty period will be repaired or replaced (with a product deemed to be equivalent) at Rockford's discretion.**

- **What is Not Covered**

1. Damage caused by accident, abuse, improper operations, water, theft
2. Any cost or expense related to the removal or reinstallation of product
3. Service performed by anyone other than Rockford or an Authorized Rockford Fosgate Service Center
4. Any product which has had the serial number defaced, altered, or removed
5. Subsequent damage to other components
6. Any product purchased outside the U.S.
7. Any product not purchased from an Authorized Rockford Fosgate Dealer

- **Limit on Implied Warranties**

Any implied warranties including warranties of fitness for use and merchantability are limited in duration to the period of the express warranty set forth above. Some states do not allow limitations on the length of an implied warranty, so this limitation may not apply. No person is authorized to assume for Rockford Fosgate any other liability in connection with the sale of the product.

- **How to Obtain Service**

Please call 1-800-669-9899 for Rockford Customer Service. You must obtain an RA# (Return Authorization number) to return any product to Rockford Fosgate. You are responsible for shipment of product to Rockford.

Ship to: **Electronics**
Rockford Corporation
Warranty Repair Department
2055 E. 5th Street
Tempe, AZ 85281
RA#: _____

Ship to: **Speakers**
Rockford Acoustic Design
(Receiving-speakers)
609 Myrtle N.W.
Grand Rapids, MI 49504
RA#: _____

MADE IN THE USA

This product is designed, developed and assembled in the USA by a dedicated group of American workers. The majority of the components used in the construction of this product are produced by American companies. However, due to the global nature of their manufacturing facilities and the electronics parts industry in general, some parts may be manufactured in other countries.

Rockford Fosgate

Rockford Corporation
546 South Rockford Drive
Tempe, Arizona 85281 U.S.A.
In U.S.A., (602) 967-3565
In Europe, Fax (49) 850-3934-014
In Japan, Fax (81) 559-79-1265