



**2.3** **100 Watt Amplifier**  
2 - channel

**2.6** **150 Watt Amplifier**  
2-channel w/crossover

**4.6** **300 Watt Amplifier**  
4-channel w/crossover

**Installation and Operation**

Dear Customer,

*Congratulations on your purchase of the world's finest brand of car audio amplifiers. At Rockford Fosgate we are fanatics about musical reproduction at its best, and we are pleased you chose our product. Through years of engineering expertise, hand craftsmanship and critical testing procedures, we have created a wide range of products that reproduce music with all the clarity and richness you deserve.*

*For maximum performance we recommend you have your new Rockford Fosgate product installed by an Authorized Rockford Fosgate Dealer, as we provide specialized training through Rockford Technical Training Institute (RTTI). Please read your warranty and retain your receipt and original carton for possible future use.*

*Great product and competent installations are only a piece of the puzzle when it comes to your system. Make sure that your installer is using 100% authentic installation accessories from Connecting Punch in your installation. Connecting Punch has everything from RCA cables and speaker wire to Power line and battery connectors. Insist on it! After all, your new system deserves nothing but the best.*

*To add the finishing touch to your new Rockford Fosgate image order your Rockford wearables, which include everything from T-shirts and jackets to hats and sunglasses.*

*To get a free brochure on Rockford Fosgate products and Rockford accessories, in the U.S. call 602-967-3565 or FAX 602-967-8132. For all other countries, call +001-602-967-3565 or FAX +001-602-967-8132.*

## **PRACTICE SAFE SOUND™**

**CONTINUOUS EXPOSURE TO SOUND PRESSURE LEVELS OVER 100dB MAY CAUSE PERMANENT HEARING LOSS. HIGH POWERED AUTOSOUND SYSTEMS MAY PRODUCE SOUND PRESSURE LEVELS WELL OVER 130dB. USE COMMON SENSE AND PRACTICE SAFE SOUND.**

If, after reading your manual, you still have questions regarding this product, we recommend that you see your Rockford Fosgate dealer. If you need further assistance, you can call us direct at 1-800-795-2385. Be sure to have your serial number, model number and date of purchase available when you call.

The serial number can be found on the outside of the box. Please record it in the space provided below as your permanent record. This will serve as verification of your factory warranty and may become useful in recovering your amplifier if it is ever stolen.

Serial Number: \_\_\_\_\_

Model Number: \_\_\_\_\_

# TABLE OF CONTENTS

Introduction .....	1
Accessory Pack .....	1
Technical Design Features .....	1
2.3, 2.6x, 4.6x Design Features .....	5
Installation Considerations .....	7
Mounting Location .....	8
Battery and Charging .....	9
Wiring the System .....	9
Using Passive Crossovers .....	11
Table of Crossover Component Values .....	12
Using the XCard .....	13
Customizing the XCard .....	13
Resistor Chart .....	14
XCard Access .....	15
2.3 & 2.6x Installation .....	16
4.6x Installation .....	19
System Diagrams .....	24
Troubleshooting .....	28
Dynamic Power Measurements .....	31
Specifications .....	33
Warranty Information .....	35
International Information .....	36

## GETTING STARTED

Welcome to Rockford Fosgate! This manual is designed to provide information for the owner, salesperson and installer. For those of you who want quick information on how to install this product, please turn to the **Installation Section** of this manual or refer to the icons listed below. Other information can be located by using the Table of Contents. We, at Rockford Fosgate, have worked very hard to make sure all the information in this manual is current. But, as we are constantly finding new ways to improve our product, this information is subject to change without notice.



Sections marked  
**ADVANCED OPERATION**  
include in-depth  
technical information



Sections marked  
**INSTALLATION**  
include "slam dunk"  
wiring connections

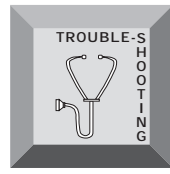

Sections marked  
**TROUBLESHOOTING**  
include recommendations  
for curing  
installation problems

# INTRODUCTION

---

This manual provides information on the features, installation and operation of the Rockford Fosgate 2.3, 2.6x and 4.6x Amplifiers. We suggest you save this manual for future reference.

We strongly recommend you have your Authorized Rockford Fosgate Dealer install your new Rockford Fosgate amplifier. If you do choose to install your amplifier yourself, please be sure to read the entire manual before beginning.

## ACCESSORY PACK

---

Installation & Operation Manual

(1) Fuseholder

(1) ATC 10 Amp Fuse (2.3)

(1) ATC 20 Amp Fuse (2.6x)

(1) ATC 30 Amp Fuse (4.6x)

(1) 3/32" Allen Wrench

## TECHNICAL DESIGN FEATURES

---

### ◆ TRANS•ANA (TRANSconductance Active Nodal Amplifier)

The *TRANS•ANA* (TRANSconductance Active Nodal Amplifier) is a circuit that allows the audio signal to pass through the amplifier at low voltage. The signal is directly level-shifted to the fixed high voltage rails via a pair of driver transistors. Signal linearity is assured by an active node formed by the drive transistors at ultrasonic frequencies. This allows amplifier performance similar to *trans•nova* which is highly stable and linear while utilizing the advantages of a non-floating power supply.

**THE RESULT:** An extended frequency bandwidth accurately supplied to the output stages of the amplifier.

## ◆ TOPAZ (Tracking Operation Pre-Amplifier Zone)

The **TOPAZ** (Tracking Operation Pre-Amplifier Zone) circuitry solves ground loop noise problems common to automotive amplifier design. This innovative new development allows vastly improved isolation of the input signal grounds from the power supply ground of the amplifier. This is accomplished by allowing the source unit to control the potential “environment” of the entire input structure or “zone” of the amplifier. This process improves the noise rejection of the amplifier by 30-40dB – an astounding 30-100 times better than amplifiers without TOPAZ.

**THE RESULT:** Elimination of troublesome ground loop noise between source and amplifier.

## ◆ MOSFET Devices

Rockford Fosgate is one of the few manufacturers in the sound community to utilize MOSFET devices in both the **power supply** and the **output stages**. **MOSFET** (Metal Oxide Semiconductor Field Effect Transistor) devices offer several important inherent advantages over the 30 year old technology of bi-polar design. These advantages include: thermal stability, switching speed, ultra low output impedance and wider bandwidth linearity. In addition, MOSFETs operate very similarly to vacuum tubes in that they are more linear than bi-polar transistors. However, MOSFETs can deliver the midrange clarity without the limitations of transient response and high frequency phase shifting normally associated with tube operation.

**THE RESULT:** Operational characteristics similar to vacuum tubes without the performance limitations of tube design.

## ◆ DSM (Discrete Surface Mount) Technology

The **DSM** (Discrete Surface Mount) manufacturing process combines the advantages of both discrete components and integrated circuitry. Rockford Fosgate is the only American amplifier manufacturer to have invested millions into this process. DSM components differ from conventional discrete components in different ways. They are more compact, more rugged, and they efficiently dissipate generated heat. Using them wherever appropriate allows the advantages associated with discrete circuitry to be retained while also providing room for both highly advanced processing features and generous PC board copper paths where needed. Their short lead-out structures allow maximum audio performance and highest signal-to-noise ratios to be obtained in amplifiers of desirable package size without resorting to “amplifier-on-a-chip” shortcuts. These advantages are shown below in Figure 1.

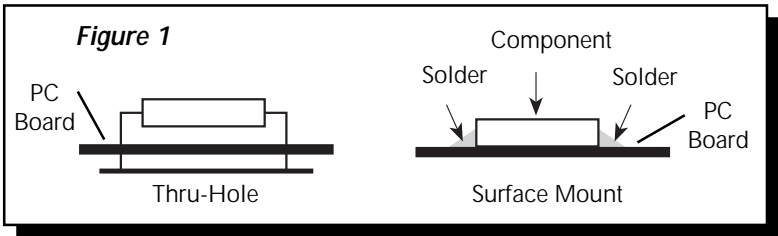

**THE RESULT:** Fewer connections, improved reliability, shorter signal paths, superior signal-to-noise ratio and awesome sonic performance.

## ◆ NOMAD (NON-Multiplying Advanced Decision)

All Rockford Fosgate amplifiers use an **analog computer process** to maximize safe output power under all operating conditions. The innovative **NOMAD** (NON-Multiplying Advanced Decision) system is the most sophisticated version of this technique ever used, bringing previously unavailable levels of accuracy, stability, temperature immunity and reliability to this critical process. NOMAD makes advanced decisions based on device voltages to precisely control the awesome levels of current available in the output MOSFETS to safe values – but only when absolutely needed.

**THE RESULT:** Extremely fast protection system that always protects the amplifier and never degrades the sound.

## ◆ High Level Inputs

The high level inputs on the Rockford Fosgate amplifiers convert the speaker line outputs (high level) to preamp line inputs (low level). This allows amplifier compatibility with a variety of source units as well as the ability to integrate into factory systems without the need for external adapters.

**THE RESULT:** Allows compatibility with factory and aftermarket source units.

## ◆ XCard Crossover (2.6x & 4.6x)

The 2.6x and 4.6x amplifiers utilize internal active crossovers. These crossovers have many performance advantages such as using discrete components for exact frequency adjustments which are far superior to potentiometers. Additionally, the XCard can be configured for high-pass, low-pass and full range operation. With slight modification, many crossover frequencies and slope configurations can be achieved.

**THE RESULT:** Increased system design flexibility with a precise electronic crossover without the limitations of conventional potentiometer designs.

# 2.3, 2.6x, 4.6x DESIGN FEATURES

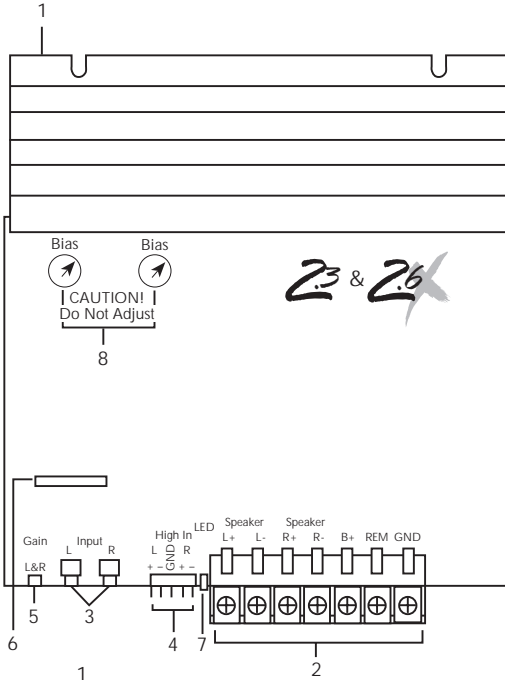

**CAUTION!** Any adjustment to the Bias controls may damage your amplifier and will void your warranty.

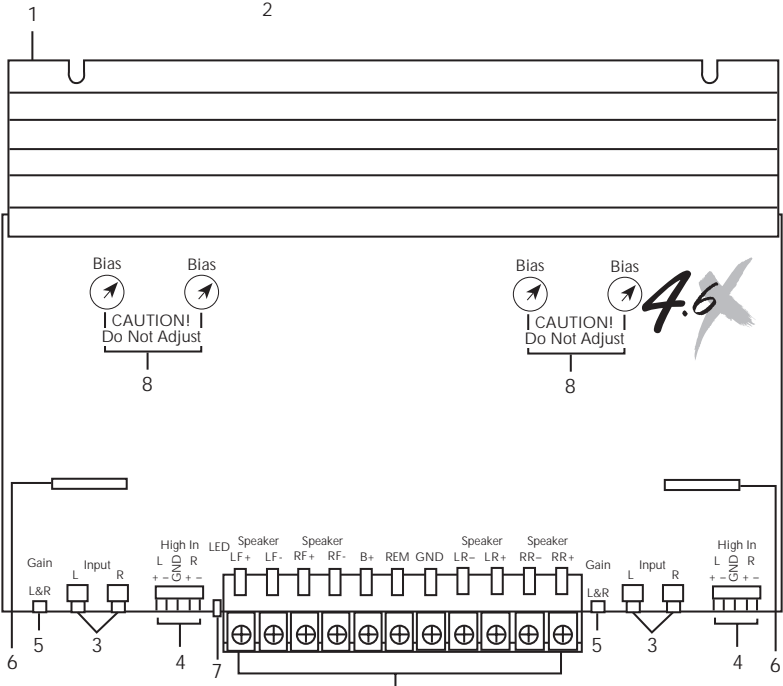



**1. Extruded Heatsink**

The extruded aluminum heatsink of the RF amplifier dissipates heat generated by the amplifier's circuitry.

**2. Power/Speaker Barrier Strip**

The barrier strip uses screw terminals that will accept #10 spade lugs or bare speaker and power wire sizes from 10-18 AWG. These gold-plated connectors are immune to corrosion that will cause signal degradation.

**3. RCA Input Jacks**

The industry standard RCA jack provides an easy connection for signal level input. They are gold-plated to resist the signal degradation caused by corrosion.

**4. High Level Inputs**

The high level input connectors accept 1/8" spade lugs for the connection of a source unit that has only speaker line (high level) outputs.

**5. Input Sensitivity Controls**

The input level controls are preset for 500mV which will match the output of most source units. They can be adjusted to match output levels from a variety of source units.

**6. Internal Crossover**

The built-in crossover card is configurable for a multitude of operating frequencies. The orientation of the card in its socket determines its function of high-pass, low-pass or full range operation.

**7. LED Power Indicator**

The LED gives a visual indication of the status of the amplifier, lighting when the unit is turned on.

**8. Bias Controls**

The Bias controls are preset at the factory and are not user adjustable. **CAUTION! ANY ADJUSTMENT TO THE BIAS CONTROLS WILL VOID YOUR WARRANTY!**

# INSTALLATION CONSIDERATIONS

---

The following is a list of tools you will need for installing the amplifier:

Wire Cutters	#2 Phillips Screwdriver
Wire Strippers	Assorted wire connectors
Wire Crimpers	Battery Post Wrench
Voltmeter	Electric Hand Drill with assorted bits

This section focuses on some of the vehicle considerations for installing your new amplifier. Checking your battery and present sound system, as well as pre-planning your system layout and best wiring routes will save installation time. When deciding on the layout of your new system, be sure that each component will be easily accessible for making adjustments.

Before beginning any installation, be sure to follow these simple rules:

1. Be sure to carefully read and understand the instructions before attempting to install the amplifier.
2. **For safety**, disconnect the negative lead from the battery prior to beginning the installation.
3. For easier assembly, we suggest you run all wires prior to mounting your amplifier in place.
4. Route all of the RCA cables close together and away from any high current wires.
5. Use high quality connectors for a reliable installation and to minimize signal or power loss.
6. **Think before you drill!** Be careful not to cut or drill into gas tanks, fuel lines, brake or hydraulic lines, vacuum lines or electrical wiring when working on any vehicle.
7. Never run wires underneath the vehicle. Running the wires inside the vehicle provides the best protection.
8. Avoid running wires over or through sharp edges. Use rubber or plastic grommets to protect any wires routed through metal, especially the firewall.
9. **ALWAYS** protect the battery and electrical system from damage with proper fusing. Install a fuseholder and appropriate fuse on the +12V power wire within 18" (45.7 cm) of the battery terminal.
10. When grounding to the chassis of the vehicle, scrape all paint from the metal to ensure a good, clean ground connection. Grounding connections should be as short as possible and always be connected to metal that is welded to the main body, or chassis, of the vehicle.

# MOUNTING LOCATION

---

The mounting location and position of your amplifier will have a great effect on its ability to dissipate the heat generated during normal operation. The design of our aluminum heatsink serves to easily dissipate the heat generated over a wide range of operating conditions. However, to maximize the performance of your amplifier, care should be taken to ensure adequate ventilation.

## Trunk Mounting

*Mounting the amplifier vertically on a surface with the fin grooves running up and down will provide the best cooling of the amplifier.*

Mounting the amplifier on the floor of the trunk will work but provides less cooling capability than vertical mounting.

Mounting the amplifier upside down to the rear deck of the trunk will not provide proper cooling and will severely affect the performance of the amplifier and is strongly **not** recommended.

## Passenger Compartment Mounting

Mounting the amplifier in the passenger compartment will work as long as you provide a sufficient amount of air for the amplifier to cool itself. If you are going to mount the amplifier under the seat of the vehicle, you must have at least 1" (2.54cm) of air gap around the amplifier's heatsink.

Mounting the amplifier with less than 1" (2.54cm) of air gap around the amplifier's heatsink in the passenger compartment will not provide proper cooling and will severely affect the performance of the amplifier and is strongly **not** recommended.

## Engine Compartment Mounting

Rockford Fosgate amplifiers should **never** be mounted in the engine compartment. Not only will this void your warranty but could create an embarrassing situation caused by the ridicule from your friends.

## BATTERY AND CHARGING

---

Amplifiers will put an increased load on the vehicle's battery and charging system. We recommend checking your alternator and battery condition to ensure that the electrical system has enough capacity to handle the increased load of your stereo system. Stock electrical systems which are in good condition should be able to handle the extra load of any Rockford amplifier without problems, although battery and alternator life can be reduced slightly. To maximize the performance of your Rockford Fosgate amplifier, we suggest the use of a heavy duty battery, high output alternator and an energy storage capacitor.

## WIRING THE SYSTEM

---

**CAUTION:** *Avoid running power wires near the low level input cables, antenna, power leads, sensitive equipment or harnesses. The power wires carry substantial current and could induce noise into the audio system.*

- **For safety**, disconnect the negative lead from the battery prior to beginning the installation.
1. Remove the cover and configure the internal XCard crossovers prior to installation. Refer to "Using the XCard" (page 13) for further information.
  2. Plan the wire routing. Take care when running signal level RCA cables to keep them close together but isolated from the amplifier's power cables and any high power auto accessories, especially electric motors. This is done to prevent coupling the noise from radiated electrical fields into the audio signal. When feeding the wires through the firewall or any metal barrier, protect them with plastic or rubber grommets to prevent short circuits. Leave the wires long at this point to adjust for a precise fit at a later time.
  3. Prepare the **Power** cable for attachment to the amplifier by stripping 1/2" of insulation from the end of the wire. Insert the bared wire into the B+ terminal and tighten the set screw to secure the cable in place.

**NOTE:** *The B+ cable MUST be fused 18" or less from the vehicle's battery. Install the fuseholder under the hood and prepare the cable ends as stated above. Connections should be water tight.*

Trim the power cable within 18" of the battery and strip 1/2" of insulation from the end of the wire. **Cut the wire loop that is attached to the fuseholder in half and splice the fuse into the power line using appropriate inline connectors.** Use the section of cable that was trimmed earlier and connect it to the other end of the fuseholder.

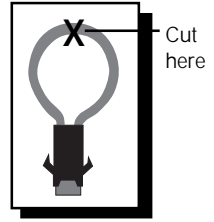

4. Strip 1/2" from the battery end of the power cable and crimp a large ring terminal to the cable. Use the ring terminal to connect to the battery positive terminal. **Do not install the fuse at this time.**
5. Prepare the **Ground** cable for attachment to the amplifier by stripping 1/2" of insulation from the end of the wire. Insert the bared wire into the GND terminal and tighten the set screw to secure the cable in place. Prepare the chassis ground by scraping any paint from the metal surface and thoroughly clean the area of all dirt and grease. Strip the other end of the wire and attach a ring connector. Fasten the cable to the chassis using a non-anodized screw and a star washer.
6. Prepare the **REM** turn-on wire for connection to the amplifier by stripping 1/2" of insulation from the wire end. Insert the bared wire into the REM terminal and tighten the set screw to secure the cable into place. Connect the other end of the REM wire to a switched 12 volt positive source. The switched voltage is usually taken from the source unit's auto antenna or the accessory lead. If the source unit does not have these outputs available, the recommended solution is to wire a mechanical switch in line with a 12 volt source to activate the amplifier.
7. Securely mount the amplifier to the vehicle or amp rack. Be careful not to mount the amplifier on cardboard or plastic panels. Doing so may enable the screws to pull out from the panel due to road vibration or sudden vehicle stops.
8. Connect the source signal to the amplifier by plugging the RCA cables into the input jacks at the amplifier.
9. Connect the speakers. Strip the speaker wires 1/2" and insert into the speaker terminal and tighten the set screw to secure into place. Be sure to maintain proper speaker polarity. **DO NOT chassis ground any of the speaker leads as unstable operation may result.**
10. Perform a final check of the completed system wiring to ensure that all connections are accurate. Check all power and ground connections for frayed wires and loose connections which could cause problems.

# USING PASSIVE CROSSOVERS

---



A passive crossover is a circuit that uses capacitors and/or coils and is placed on speaker leads between the amplifier and speaker. The crossover delegates a specific range of frequencies to the speaker for optimum driver performance. A crossover network can perform one of three functions: High-Pass (capacitors), Low-Pass (inductors or coils) and Bandpass (combination of capacitor and coil).

The most commonly used passive crossover networks are 6dB/octave systems. These are easy to construct and require one component per filter. Placing this filter in series with the circuit will reduce power to the speaker by 6dB/octave above or below the crossover point depending on whether it is a high-pass or low-pass filter. More complex systems such as 12dB/octave or 18dB/octave can cause impedance problems if not professionally designed.

Passive crossovers are directly dependent upon the speaker's impedance and component value for accuracy. When passive crossover components are used in multiple speaker systems, the crossover's effect on the overall impedance should be taken into consideration along with the speaker's impedance when determining amplifier loads. **CAUTION: The Rockford Fosgate amplifiers are not recommended for impedance loads below 2Ω stereo and 4Ω bridged (mono) loads.**

# TABLE OF CROSSOVER COMPONENT VALUES

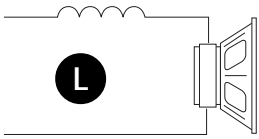

6 dB/Octave Low-Pass

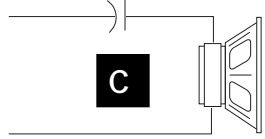

6 dB/Octave High-Pass

Freq. Hertz	Speaker Impedance					
	2 OHMS		4 OHMS		8 OHMS	
	<b>L</b>	<b>C</b>	<b>L</b>	<b>C</b>	<b>L</b>	<b>C</b>
80	4.1mH	1000µF	8.2mH	500µF	16mH	250µF
100	3.1mH	800µF	6.2mH	400µF	12mH	200µF
130	2.4mH	600µF	4.7mH	300µF	10mH	150µF
200	1.6mH	400µF	3.3mH	200µF	6.8mH	100µF
260	1.2mH	300µF	2.4mH	150µF	4.7mH	75µF
400	.8mH	200µF	1.6mH	100µF	3.3mH	50µF
600	.5mH	136µF	1.0mH	68µF	2.0mH	33µF
800	.41mH	100µF	.82mH	50µF	1.6mH	26µF
1000	.31mH	78µF	.62mH	39µF	1.2mH	20µF
1200	.25mH	66µF	.51mH	33µF	1.0mH	16µF
1800	.16mH	44µF	.33mH	22µF	.68mH	10µF
4000	.08mH	20µF	.16mH	10µF	.33mH	5µF
6000	51µH	14µF	.10mH	6.8µF	.20mH	3.3µF
9000	34µH	9.5µF	68µH	4.7µF	.15mH	2.2µF
12000	25µH	6.6µF	51µH	3.3µF	100µH	1.6µF

## 6 dB/Octave High-Pass and Low-Pass Filters

L = Low-Pass (Inductor)  
 C = High-Pass (Capacitor)

For more information, see your Authorized Rockford Fosgate Dealer.

# USING THE XCARD

The crossover functions are controlled through the use of an XCard and can be set for high-pass, low-pass or full range operation. The 100Hz XCard shipped with your amplifier is set for Full Range. Each crossover card has two faces: one face operates **Full Range**, the other has arrows to indicate the edge for selecting **HP** (high-pass) or **LP** (low-pass) operation. Orient the card with the desired operating edge, indicated by the arrow, toward the socket terminals inside the amplifier. Firmly, but carefully, plug the card into the socket.

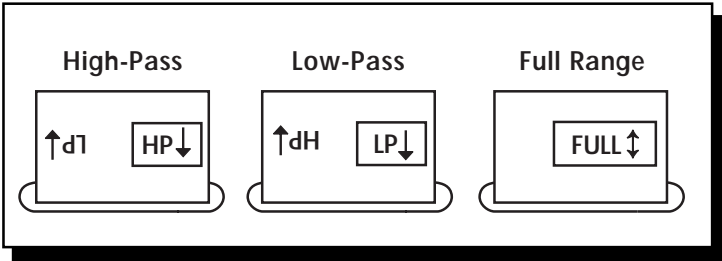

# CUSTOMIZING THE XCARD

The crossover point can be altered by changing the resistor value. Use the following formula to select the appropriate resistor value to be placed on the XCard.

$$\frac{3386}{f_o} = R \text{ (in k}\Omega\text{) for } .047\mu\text{f cap}$$

$$\frac{7234}{f_o} = R \text{ (in k}\Omega\text{) for } .022\mu\text{f cap}$$

The actual formula is:

$$R = \frac{1}{2\pi f_o c}$$

Where:  $R = \Omega$

$f_o$  = desired crossover frequency

$c$  = capacitor in farads

ex:  $.047 \times 10^{-6}$  for .047mf cap

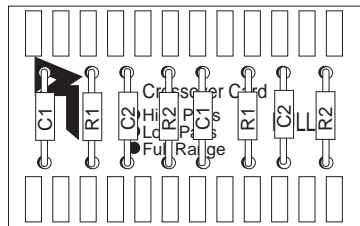





# RESISTOR CHART

Our tests have shown that using 0.047 $\mu$ F capacitors for frequencies below 100Hz, and 0.022 $\mu$ F capacitors for frequencies above 100Hz, result in more linear crossover control. Refer to the Specifications page to determine the capacitor value of each supplied XCard.

**Butterworth Alignment  $Q = .707$**   
1% resistors used with 0.047 $\mu$ F caps

Frequency	R1	R2
20Hz	169k $\Omega$	169k $\Omega$
25Hz	133k $\Omega$	133k $\Omega$
30Hz	110k $\Omega$	110k $\Omega$
35Hz	95.3k $\Omega$	95.3k $\Omega$
40Hz	84.5k $\Omega$	84.5k $\Omega$
45Hz	75k $\Omega$	75k $\Omega$
50Hz	68.1k $\Omega$	68.1k $\Omega$
55Hz	61.9k $\Omega$	61.9k $\Omega$
60Hz	56.2k $\Omega$	56.2k $\Omega$
65Hz	52.3k $\Omega$	52.3k $\Omega$
70Hz	48.7k $\Omega$	48.7k $\Omega$
75Hz	45.3k $\Omega$	45.3k $\Omega$
80Hz	42.2k $\Omega$	42.2k $\Omega$
85Hz	40.2k $\Omega$	40.2k $\Omega$
90Hz	37.4k $\Omega$	37.4k $\Omega$
200Hz	16.9k $\Omega$	16.9k $\Omega$
300Hz	11.3k $\Omega$	11.3k $\Omega$
400Hz	8.45k $\Omega$	8.45k $\Omega$
500Hz	6.65k $\Omega$	6.65k $\Omega$
600Hz	5.62k $\Omega$	5.62k $\Omega$
700Hz	4.75k $\Omega$	4.75k $\Omega$
800Hz	4.22k $\Omega$	4.22k $\Omega$
900Hz	3.74k $\Omega$	3.74k $\Omega$
1kHz	3.40k $\Omega$	3.40k $\Omega$
1.2kHz	2.80k $\Omega$	2.80k $\Omega$
2kHz	1.69k $\Omega$	1.69k $\Omega$
3kHz	1.10k $\Omega$	1.10k $\Omega$
4kHz	845 $\Omega$	845 $\Omega$
5kHz	665 $\Omega$	665 $\Omega$
6kHz	562 $\Omega$	562 $\Omega$
7kHz	487 $\Omega$	487 $\Omega$
8kHz	422 $\Omega$	422 $\Omega$

**Butterworth Alignment  $Q = .707$**   
1% resistors used with 0.022 $\mu$ F caps

Frequency	R1	R2
20Hz	357k $\Omega$	357k $\Omega$
25Hz	287k $\Omega$	287k $\Omega$
30Hz	237k $\Omega$	237k $\Omega$
35Hz	205k $\Omega$	205k $\Omega$
40Hz	178k $\Omega$	178k $\Omega$
45Hz	162k $\Omega$	162k $\Omega$
50Hz	143k $\Omega$	143k $\Omega$
55Hz	130k $\Omega$	130k $\Omega$
60Hz	121k $\Omega$	121k $\Omega$
65Hz	110k $\Omega$	110k $\Omega$
70Hz	102k $\Omega$	102k $\Omega$
75Hz	95.3k $\Omega$	95.3k $\Omega$
80Hz	90.9k $\Omega$	90.9k $\Omega$
85Hz	84.5k $\Omega$	84.5k $\Omega$
90Hz	80.6k $\Omega$	80.6k $\Omega$
200Hz	35.7k $\Omega$	35.7k $\Omega$
300Hz	23.7k $\Omega$	23.7k $\Omega$
400Hz	17.8k $\Omega$	17.8k $\Omega$
500Hz	14.3k $\Omega$	14.3k $\Omega$
600Hz	12.1k $\Omega$	12.1k $\Omega$
700Hz	10.2k $\Omega$	10.2k $\Omega$
800Hz	9.9k $\Omega$	9.9k $\Omega$
900Hz	8.6k $\Omega$	8.6k $\Omega$
1.0kHz	7.15k $\Omega$	7.15k $\Omega$
1.2kHz	6.04k $\Omega$	6.04k $\Omega$
2.0kHz	3.57k $\Omega$	3.57k $\Omega$
3.0kHz	2.37k $\Omega$	2.37k $\Omega$
4.0kHz	1.76k $\Omega$	1.76k $\Omega$
5.0kHz	1.43k $\Omega$	1.43k $\Omega$
6.0kHz	1.21k $\Omega$	1.21k $\Omega$
7.0kHz	1.02k $\Omega$	1.02k $\Omega$
8.0kHz	909 $\Omega$	909 $\Omega$

# XCARD ACCESS

The internal XCard crossover(s) are accessible by removing the top cover from the amplifier. The XCard should be inserted with the filter side (HP, LP or FULL RANGE) facing the metal contacts inside the socket (toward RCA jacks).

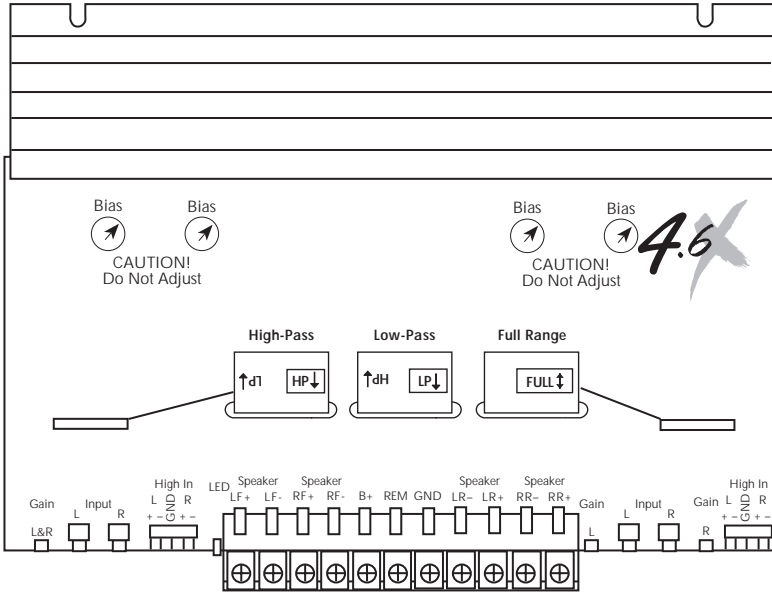

- **Remove Four Allen Screws** from cover with supplied Allen wrench (3/32")
- **Insert XCard** into socket with HP, LP, or FULL RANGE facing RCA jacks



## 2.3 & 2.6x INSTALLATION

### High Level Input – “Single Ended” Type

This configuration is used for source units that have “Single Ended” speaker outputs. Only the “+” output is “hot,” whereas the “-” or “common” are common grounded. To verify your source unit has these outputs, connect an ohm meter across the “-” output and radio chassis for a reading of 0Ω.

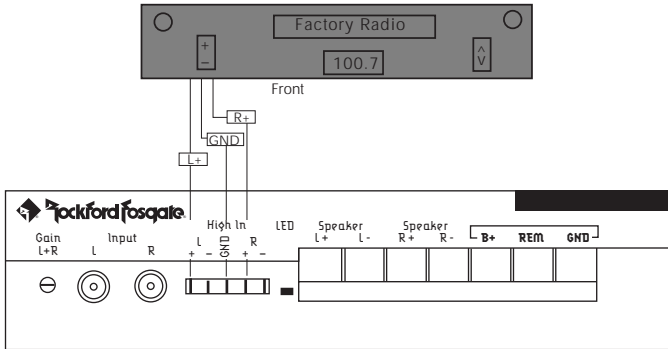

- **L+ and R+ Inputs** are connected to corresponding “+” speaker outputs
- **L- and R- Inputs** are *not used*
- **GND Input** is connected to “-” speaker outputs

### High Level Input – “B.T.L.” Type

This configuration is used for source units that have “B.T.L.” speaker outputs (Bridged Transformer Less *not* Bacon Tomato & Lettuce). Both “+” and “-” outputs are considered “hot” or “floating.”

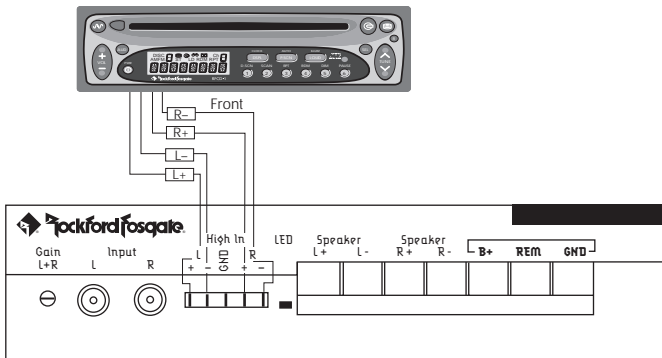

- **L+ and R+ Inputs** are connected to corresponding “+” speaker outputs
- **L- and R- Inputs** are connected to corresponding “-” speaker outputs
- **GND Input** is *not used* unless noise problems arise

**CAUTION:** Use 1/8" female connectors when using the high level inputs and **DO NOT** solder wires directly to the connector



# Power Connections

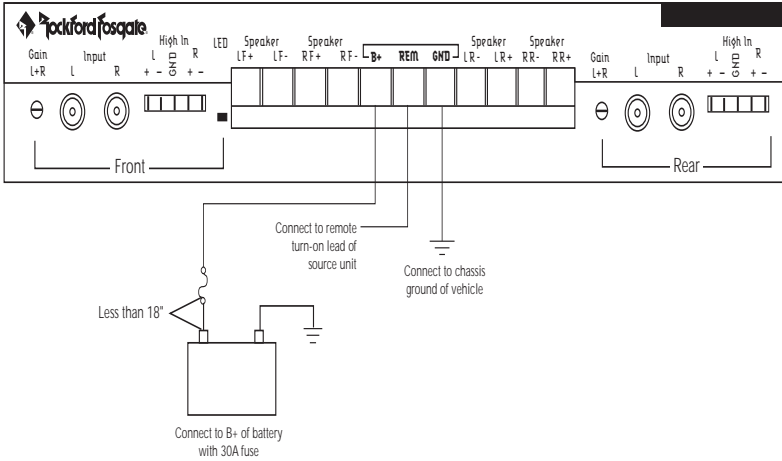

# Stereo Operation

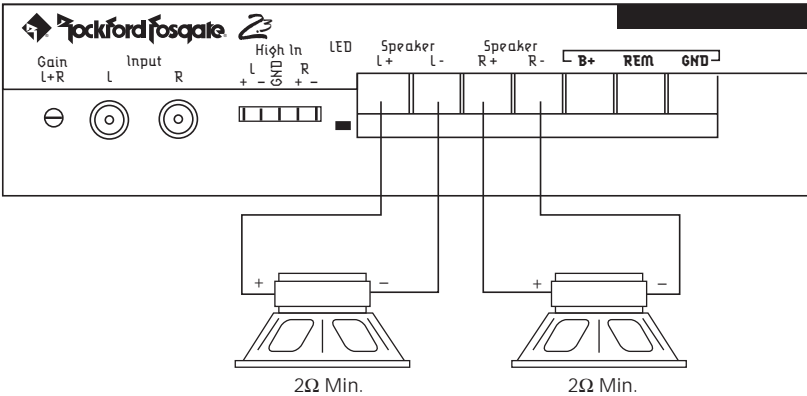

- **RCA Inputs** are connected to *both left and right* inputs
- **Impedance Load** for each channel should be **2Ω minimum**
- **XCard** can be set for High-Pass, Low-Pass or Full Range



## Mono Operation

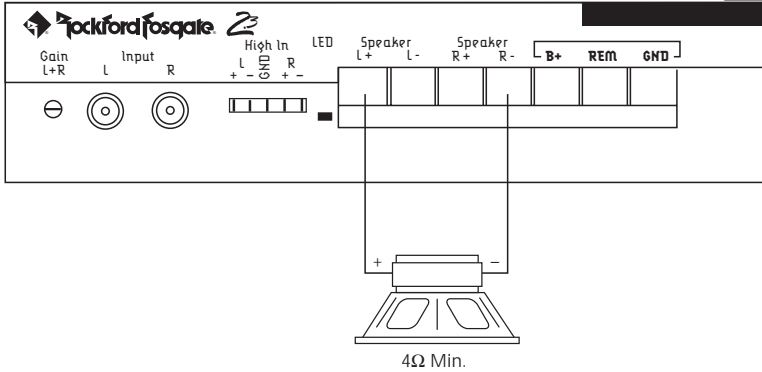

- **RCA Inputs** are connected to *both left and right* inputs
- **Impedance Load** for mono channel should be **4Ω minimum**
- **XCard** can be set for High-Pass, Low-Pass or Full Range

## Stereo/Mono Operation

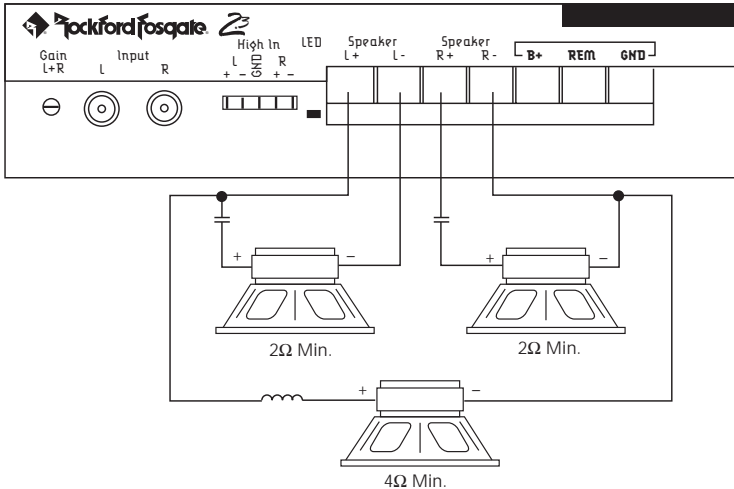

- **RCA Inputs** are connected to *both left and right* inputs
- **Impedance Load** for each stereo channel should be **2Ω minimum**
- **Impedance Load** for mono channel should be **4Ω minimum**
- **XCard** set for Full Range
- **Passive Crossovers** are needed for proper Stereo/Mono operation



# 4.6x INSTALLATION

## High Level Input – “Single Ended” Type

This configuration is used for source units that have “Single Ended” speaker outputs. Only the “+” output is “hot,” whereas the “-” or “common” are common grounded. To verify your source unit has these outputs, connect an ohm meter across the “-” output and radio chassis for a reading of 0Ω.

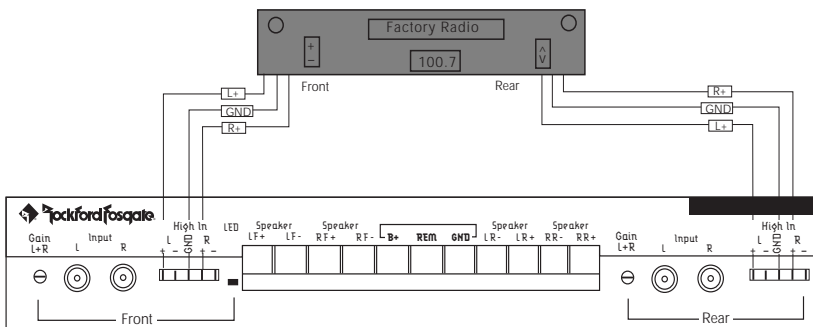

- **L+ and R+ Inputs** are connected to corresponding “+” speaker outputs
- **L- and R- Inputs** are *not used*
- **GND Input** is connected to “-” speaker outputs

## High Level Input – “B.T.L.” Type

This configuration is used for source units that have “B.T.L.” speaker outputs (Bridged Transformer Less *not* Bacon Tomato & Lettuce). Both “+” and “-” outputs are considered “hot” or “floating.”

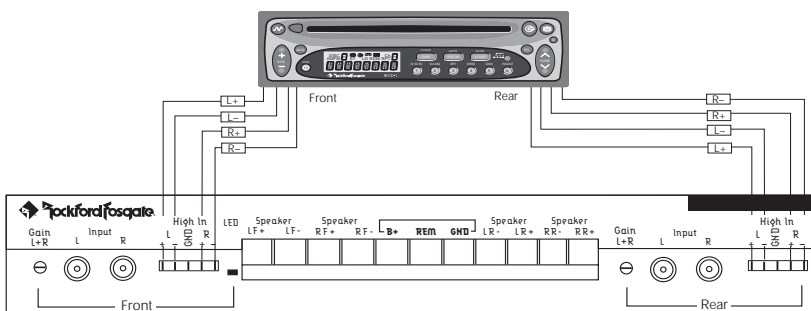

- **L+ and R+ Inputs** are connected to corresponding “+” speaker outputs
- **L- and R- Inputs** are connected to corresponding “-” speaker outputs
- **GND Input** is *not used* unless noise problems arise

**CAUTION:** Use 1/8" female connectors when using the high level inputs and **DO NOT** solder wires directly to the connector

## Power Connections

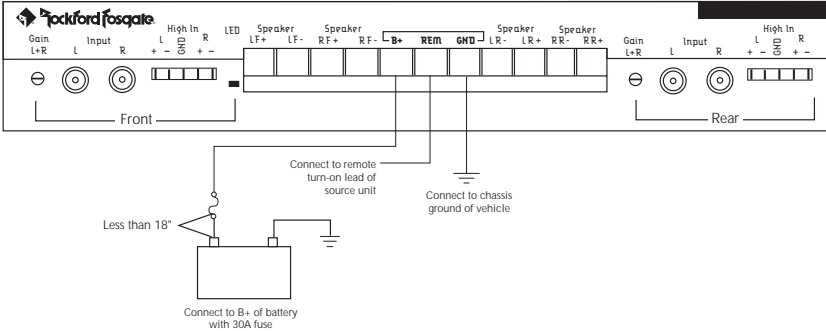

## 2-Channel Stereo Operation

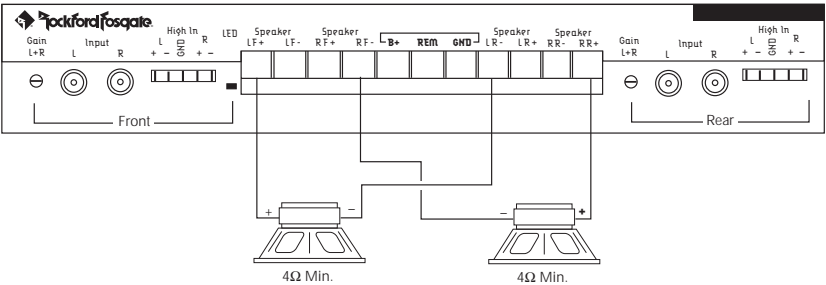

- **RCA Inputs** connect to *all* inputs
- **Gain Controls** for front and rear channels *set equally* to balance each subwoofer
- **Impedance Load** for left bridged channel should be **4Ω minimum**
- **Impedance Load** for right bridged channel should be **4Ω minimum**
- **Front XCard** can be set for High-Pass, Low-Pass or Full Range
- **Rear XCard** can be set for High-Pass, Low-Pass or Full Range



## 2-Channel Mono Operation

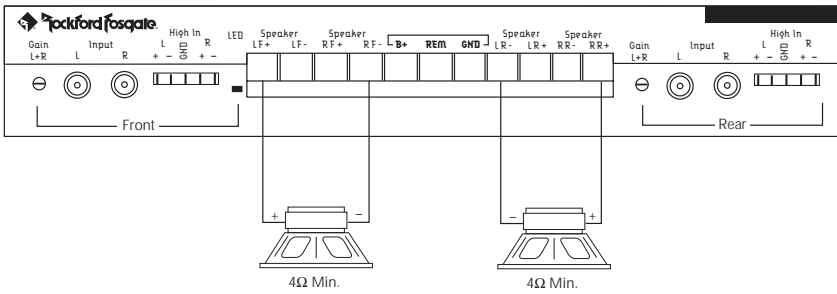

- **RCA Inputs** connect to *all* inputs
- **Gain Controls** for front and rear channels *set equally* to balance subwoofers
- **Impedance Load** for front bridged channel should be *4Ω minimum*
- **Impedance Load** for rear bridged channel should be *4Ω minimum*
- **XCards** for front and rear are set identically as High-Pass, Low-Pass or Full Range

## 3-Channel Operation

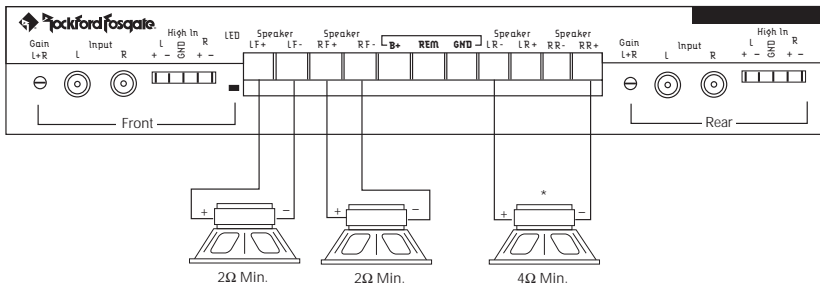

- **RCA Inputs** connect to *all* inputs
- **Gain** for front and rear channels operate *independently*
- **Impedance Load** for front stereo channels should be *2Ω minimum*
- **Impedance Load** for rear bridged channel should be *4Ω minimum*
- **Front XCard** can be set for High-Pass, Low-Pass or Full Range
- **Rear XCard** can be set for High-Pass, Low-Pass or Full Range

\* **NOTE:** Invert the speaker wire polarity (+ and -) on the rear channels if XCard for front channel is set to HP and XCard for rear channel is set to LP (or vice versa)





## 4-Channel Stereo Operation

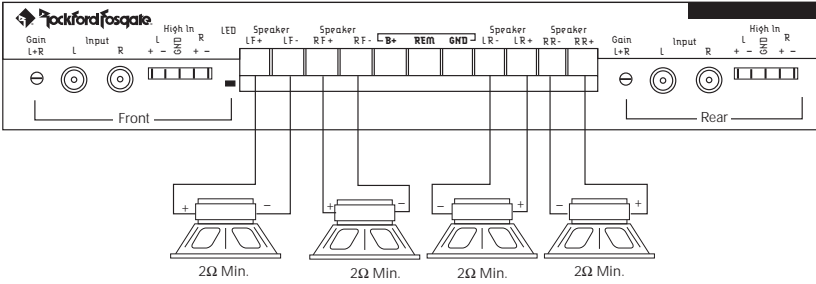

- **RCA Inputs** connect to *all* inputs
- **Gain Controls** for front and rear channels operate *independently*
- **Impedance Load** for each stereo channel should be *2Ω minimum*
- **Front XCard** can be set for High-Pass, Low-Pass or Full Range
- **Rear XCard** can be set for High-Pass, Low-Pass or Full Range

## 4-Channel Stereo/Single Mono Operation

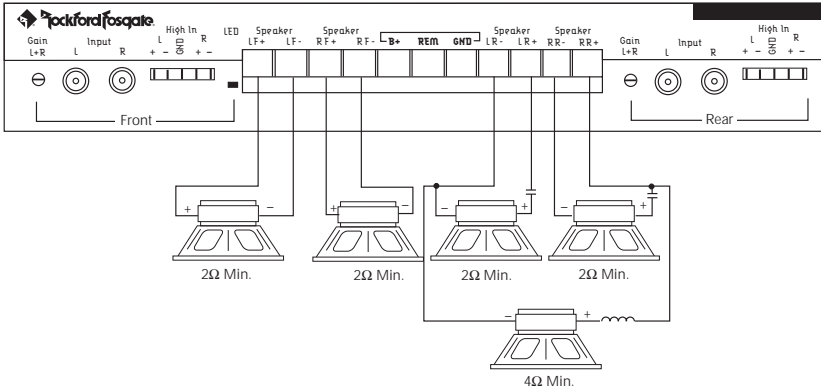

- **RCA Inputs** connect to *all* inputs
- **Gain Controls** for front & rear channels operate *independently*
- **Impedance Load** for front & rear stereo channels should be *2Ω minimum*
- **Impedance Load** for rear mono channel should be *4Ω minimum*
- **Front XCard** can be set for High-Pass, Low-Pass or Full Range
- **Rear XCard** set for Full Range
- **Passive Crossovers** are needed on rear channels for proper Stereo/Mono operation



## 4-Channel Stereo/Dual Mono Operation

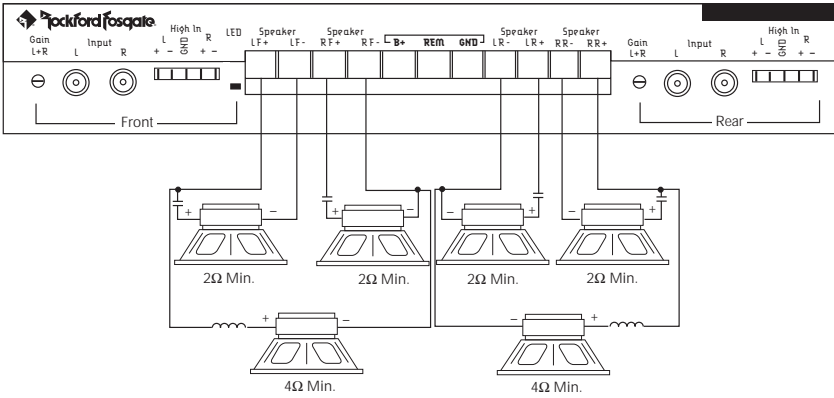

- **RCA Inputs** connect to *all* inputs
- **Gain Controls** for front and rear channels set *equally* to balance subwoofers
- **Impedance Load** for front & rear stereo channels should be *2Ω minimum*
- **Impedance Load** for front & rear mono channels should be *4Ω minimum*
- **Front XCard** set for Full Range
- **Rear XCard** set for Full Range
- **Passive Crossovers** are needed for proper Stereo/Mono operation

# SYSTEM DIAGRAMS

## 60 Watt System (rated @ 4 ohms)

### Total Power Delivery (RMS)

Tweeters	60 Watts
Midrange	60 Watts
Woofer	120 Watts

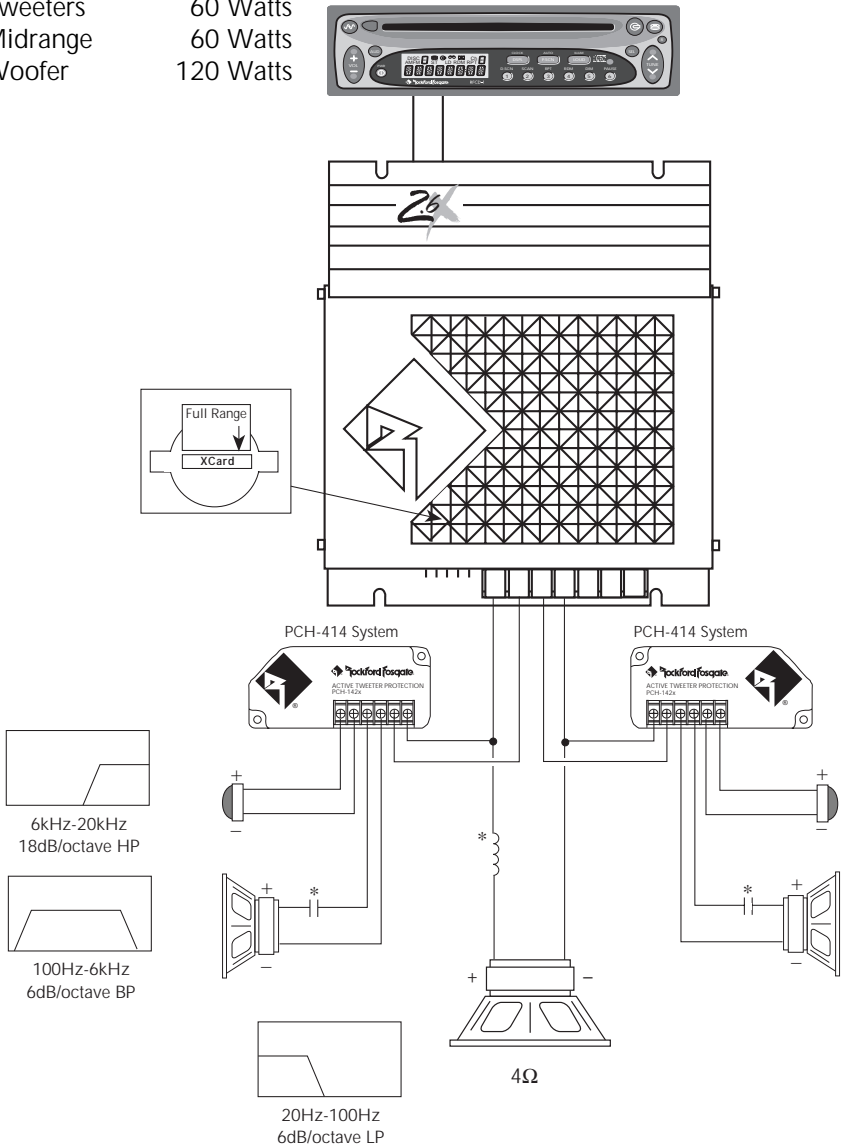

\*Refer to Table of **Crossover Component Values** on page 12 or ask your local Authorized Rockford Fosgate Dealer for selecting proper capacitor/coil values.

# 120 Watt System (rated @ 4 ohms)

## Total Power Delivery (RMS)

Front                60 Watts  
 Rear                60 Watts  
 Woofers            120 Watts

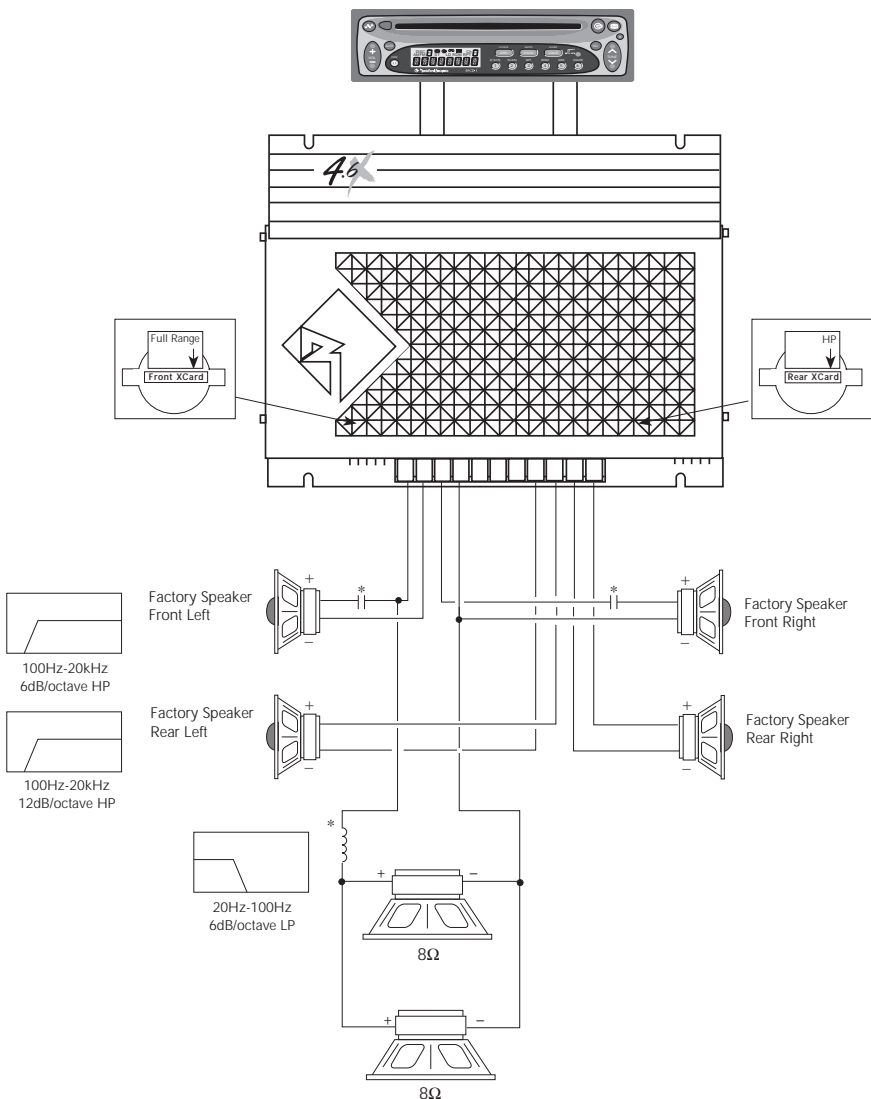

\*Refer to Table of **Crossover Component Values** on page 12 or ask your local Authorized Rockford Fosgate Dealer for selecting proper capacitor/coil values.

# 150 Watt System (rated @ 4 ohms)

## Total Power Delivery (RMS)

Tweeters 90 Watts  
 Midrange 90 Watts  
 Woofer 120 Watts

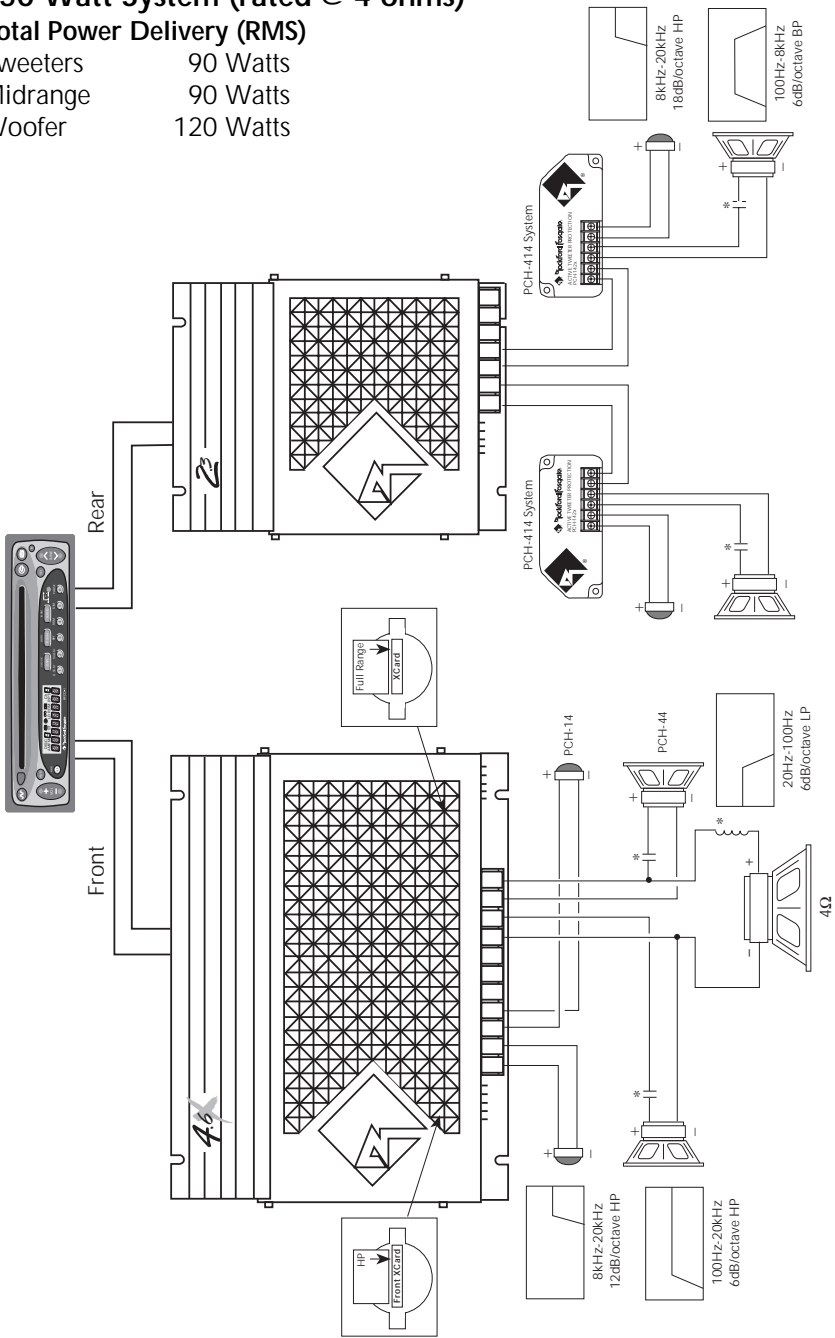

\*Refer to Table of **Crossover Component Values** on page 12 or ask your local Authorized Rockford Fosgate Dealer for selecting proper capacitor/coil values.

# 300 Watt System (rated @ 4 ohms)

## Total Power Delivery (RMS)

Tweeters	120 Watts
Midrange	120 Watts
Woofers	120 Watts

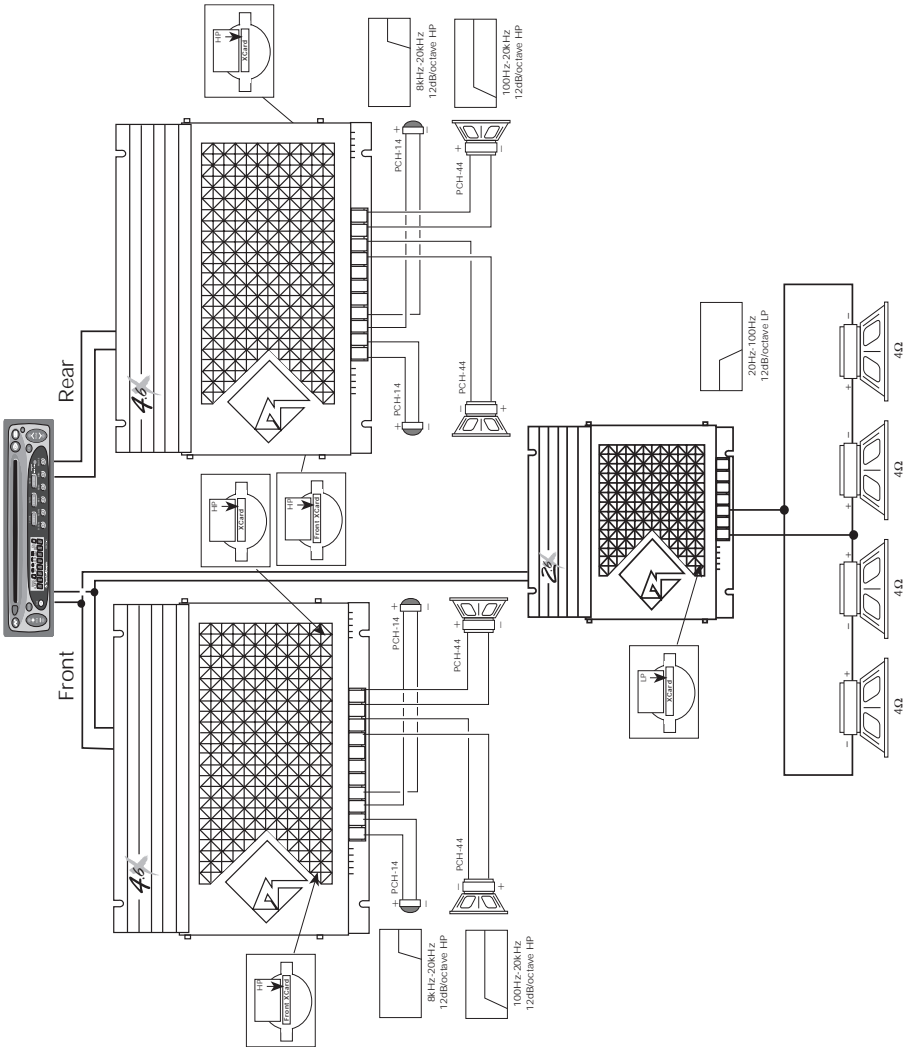

\*Refer to Table of **Crossover Component Values** on page 12 or ask your local Authorized Rockford Fosgate Dealer for selecting proper capacitor/coil values.

# TROUBLESHOOTING



Symptom	Diagnosis	Remedy
<b>Amplifier does not turn on</b> (Power LED is off)	Voltage applied to the REM terminal of the amplifier is not between 10.5 and 15.5 volts or there is no voltage present.	Check the alternator, battery, fuse, and wiring and repair as necessary. If the voltage is above 15.5 volts, have the electrical system inspected by an authorized car service center.
	Voltage to the B+ terminal of the amplifier is not between 10.5 and 15.5 volts or there is no voltage present.	Check the alternator, battery, fuse, and wiring and repair as necessary. If the voltage is above 15.5 volts, have the electrical system inspected by an authorized car service center.
	Amplifier is not properly grounded.	Check wiring and repair as necessary.
<b>Amplifier has no sound</b> (Power LED is on)	RCA Input from source unit is not connected or not functioning properly.	Check connections, substitute with known working source and cables and repair or replace as necessary.
	XCard is missing or not placed properly in cross-over slots.	Check XCard position and repair or replace as necessary.
	Speaker leads are shorted to each other or to the chassis of the vehicle.	Disconnect existing speakers and test with known working speakers and wires. If amplifier plays, check and repair wiring and installation of speakers as necessary.
	Speakers are defective.	Disconnect existing speakers and test with known working speakers. If amplifier plays, check and repair speakers as necessary.



Symptom	Diagnosis	Remedy
<b>Speaker Output Low or Distorted</b>	Input gain signal for amplifier is incorrectly set.	Readjust input gains of amplifier.
	Source unit output too low or source unit has no output.	Check system with known working source and repair or replace original source as needed.
	XCard is missing or not placed properly in cross-over slots.	Check XCard position and repair or replace as necessary.
	Low battery voltage or large voltage drops to the amplifier under load.	Check the alternator, battery, fuse, and power and ground wiring. Repair as necessary.
<b>Amplifier Noise (Turn-on Pop)</b>	Voltage spike from output of preceding component is entering amplifier through input signal.	Disconnect input signal to amplifier and turn amplifier on and off. If noise is eliminated, connect REM lead of amplifier to source unit with a delay turn-on module.
	Voltage spike from remote turn-on lead is entering through REM input terminal.	Use a different 12 volt source for REM lead of amplifier (i.e., battery direct). If noise is eliminated, use a relay to isolate amplifier from noisy turn-on output.





<b>Symptom</b>	<b>Diagnosis</b>	<b>Remedy</b>
<b>Engine Noise</b>	Noise is radiating into RCA signal cable.	Check connections, and run the RCA cables on a different route away from sources of high current.
	Bad component in the signal chain.	Check connections, and bypass additional components (crossovers and equalizers) between the source unit and the amplifier. Connect one component at a time to determine the culprit. Repair or replace components as necessary.
	Noise is radiating into speaker cables.	Disconnect existing speakers and connect a test speaker to the output terminals of the amplifier. If noise is gone, reroute the speaker cables away from sources of high voltage.
	Multiple grounds in the audio system.	Check ground connections and connect amplifiers, signal processors, and other components to a central location or try a different grounding point on the chassis.
	Ground loop between source unit and antenna.	Check connections and disconnect antenna from source unit. If noise is gone, install an antenna ground loop isolator.
<b>Engine Noise with high level inputs</b>	No reference ground	Connect GND terminal of high level input to chassis of source unit.

- If noise persists, see your Authorized Rockford Fosgate Dealer.

# DYNAMIC POWER MEASUREMENTS

---

## About the Dynamic Power Measurements

The Audio Graph PowerCube is a test instrument used to measure the output of an amplifier in accordance with IHF-202 industry standards. The IHF-202 standard is a dynamic power measurement and was developed as a means of measuring power in a manner that best represents the Real World operation of an amplifier. Many manufacturers, including Rockford Fosgate, at times will measure amplifier power into a fixed resistor (4 ohm, 2 ohm). While this method is useful in some types of evaluation and testing, it is not representative of an amplifier that is connected to a speaker and playing music.

## Music

Music is dynamic; the sound waves are complex and constantly changing. In order to simulate this, the IHF-202 standard calls for the input signal to the amplifier to be a 1kHz burst tone. This signal is input (on for 20 milliseconds) and reduced 20dB for 480 milliseconds. The signal is gradually increased in level until the amplifier's output exceeds 1% Total Harmonic Distortion (THD). At 1% distortion becomes audible, therefore, any power produced above that level is considered *unusable*. Many manufacturers represent their amplifiers' output power in excess of 10% distortion. They use many names for this measurement, such as Total Maximum Power or Maximum Output Power. This is not indicative of the *actual usable output power*.

## Listening to Loudspeakers - Not Resistors

A loudspeaker is not a resistor. A resistor's value (resistance measured in ohms) is fixed. A loudspeaker's impedance is dynamic. It is constantly changing in value, dependent upon the frequency of the input signal. Therefore, measuring power with the amplifier loaded into a 4 ohm resistor is not the same as measuring power with the amplifier connected to a 4 ohm speaker. Most people do not listen to music through a resistor.

A 4 ohm speaker may experience a drop in impedance 4-6 times lower than its nominal (printed) impedance. A speaker will also create phase shifts in the signal that is passed through it. These phase shifts happen because a speaker is an inductor (voice coil) and a capacitor (compliance of the surround/spider), as well as a resistor (voice coil wire).

To simulate a speaker the Audio Graph PowerCube measures output power into 20 different loads. It tests at 8 ohms, 4 ohms, 2 ohms and 1 ohm. Each of these impedances is also tested at  $-60^\circ$ ,  $-30^\circ$ ,  $0^\circ$ ,  $+30^\circ$  and  $+60^\circ$  phase angles. These different impedances and phase angles represent the shifts in impedance and phase that can occur in a typical loudspeaker.

## Information Cubed

The data acquired in the testing procedure is then graphed in the form of a 3-dimensional cube, hence the name **PowerCube**.

The *Phase Angle* is expressed on the horizontal axis, the *Output Voltage* is presented on the vertical axis and the *Impedance* is displayed on the Z axis. *Output Power*, in watts, is listed on the left hand side for each impedance at each phase angle.

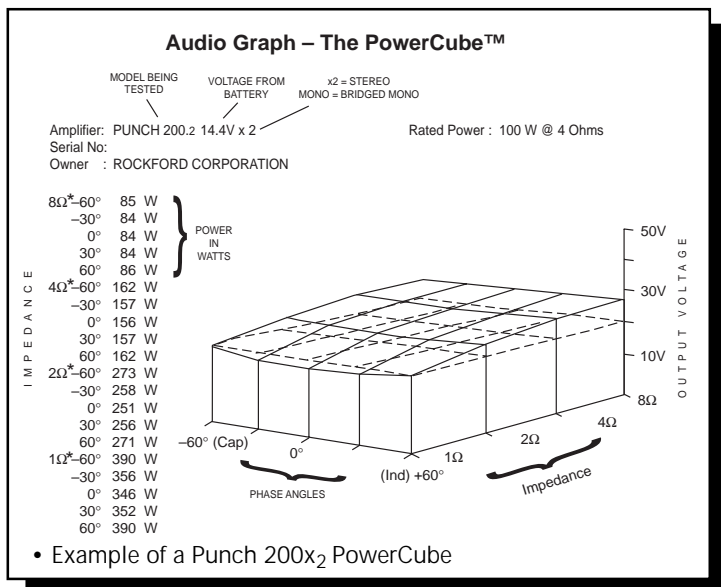

## What is an Amplifier?

An amplifier by definition is a voltage generating device, recreating the signal which is input to it identically but with increased volume. It will be connected to a reactive load (the speaker). The impedance of this load and phase of the signal passing through the load will vary, dependent upon the frequency of the input signal (music).

Therefore, a perfect amplifier will be able to maintain the same output voltage regardless of load characteristics and will not alter the signal it is reproducing. A perfect amplifier when measured by the Audio Graph PowerCube would present data that forms a perfect cube. Unfortunately, amplifiers are not perfect. The laws of physics generally prevent it. A great amplifier is about the best one can hope to attain.

As you can see by the PowerCube and as you will experience by listening, your Punch amplifier is a GREAT AMPLIFIER!

# SPECIFICATIONS

	2.3	2.6	4.6
Dynamic Power Rating (IHF 202 Standard) - Measured at 14.4 Voltage			
Per channel into a 4Ω Load	35 Watts	55 Watts	55 Watts
Per channel into a 2Ω Load	50 Watts	75 Watts	75 Watts
Bridged Mono into a 4Ω Load	100 Watts	150 Watts	150 Watts x 2
Continuous Power Rating (Competition Standard) - Measured at 14.4 Battery Voltage			
RMS continuous power <b>per channel</b> , all channels driven into a 4Ω load from 20 to 20,000 Hz with less than 0.08% Total Harmonic Distortion (THD)	15 Watts	30 Watts	30 Watts
RMS continuous power <b>per channel</b> , all channels driven into a 2Ω load from 20 to 20,000 Hz, with less than 0.30% Total Harmonic Distortion (THD)	30 Watts	60 Watts	60 Watts
RMS continuous power <b>bridged/mono</b> into a 4Ω load from 20 to 20,000 Hz with less than 0.30% Total Harmonic Distortion (THD)	60 Watts	120 Watts	120 Watts x 2

2.3

2.6

4.6

Signal-to-Noise Ratio >100dB (A-weighted)

Bandwidth 10 Hz to 250kHz  $\pm$  3dB

Damping Factor @ 4 $\Omega$  >200

Frequency Response 20 Hz to 20 kHz  $\pm$  0.5dB

Slew Rate 30V/ $\mu$ s

IM Distortion (IHF) <0.05%

Input Impedance 20,000 ohms

Input Voltage

(Low level in -RCA) Variable from 325mV to 5.5 volts

(High level in-BTL) Variable from 850mV to 15 volts

(High level in-single ended) Variable from 425mV to 7.5 volts

Protection NOMAD – Internal analog-computer output protection circuitry limits power in case of overload. Thermal switch shuts down the amplifier in case of overheating.

Factory Default Crossover 80Hz (0.047 $\mu$ f)

Crossover Slope 12dB/octave Butterworth

Battery Fusing Ratings 10 Amps 20 Amps 30 Amps

(External to Amplifier) ATC ATC ATC

Fuse Type

Dimensions 8.3" (21.1cm) W 8.3" (21.1 cm) W 8.3" (21.1cm) W

6.4" (16.2cm) L 7.4" (18.7cm) L 10.87" (27.6cm) L

2" (5.08cm) H 2" (5.08 cm) H 2" (5.08 cm) H

Specifications subject to change without notice.

# WARRANTY INFORMATION

---

Rockford Corporation offers a limited warranty on Rockford Fosgate products on the following terms:

- **Length of Warranty**

3 years on electronics	90 days on electronic B-stock (receipt required)
2 years on source units	30 days on speaker B-stock (receipt required)
  
- **What is Covered**

This warranty applies only to Rockford Fosgate products sold to consumers by Authorized Rockford Fosgate Dealers in the United States of America or its possessions. Product purchased by consumers from an Authorized Rockford Fosgate Dealer in another country are covered only by that country's Distributor and not by Rockford Corporation.
  
- **Who is Covered**

This warranty covers only the original purchaser of Rockford product purchased from an Authorized Rockford Fosgate Dealer in the United States. In order to receive service, the purchaser must provide Rockford with a copy of the receipt stating the customer name, dealer name, product purchased and date of purchase.
  
- **Products found to be defective** during the warranty period will be repaired or replaced (with a product deemed to be equivalent) at Rockford's discretion.
  
- **What is Not Covered**
  1. Damage caused by accident, abuse, improper operations, water, theft
  2. Any cost or expense related to the removal or reinstallation of product
  3. Service performed by anyone other than Rockford or an Authorized Rockford Fosgate Service Center
  4. Any product which has had the serial number defaced, altered, or removed
  5. Subsequent damage to other components
  6. Any product purchased outside the U.S.
  7. Any product not purchased from an Authorized Rockford Fosgate Dealer
  
- **Limit on Implied Warranties**

Any implied warranties including warranties of fitness for use and merchantability are limited in duration to the period of the express warranty set forth above. Some states do not allow limitations on the length of an implied warranty, so this limitation may not apply. No person is authorized to assume for Rockford Fosgate any other liability in connection with the sale of the product.
  
- **How to Obtain Service**

Please call 1-800-669-9899 for Rockford Customer Service. You must obtain an RA# (Return Authorization number) to return any product to Rockford Fosgate. You are responsible for shipment of product to Rockford.

Ship to:

**Electronics**

Rockford Corporation  
Warranty Repair Department  
2055 E. 5th Street  
Tempe, AZ 85281  
RA#: \_\_\_\_\_



Por favor, lea las instrucciones siguientes para la instalación de este producto. El hecho de proceder al montaje sin haber leído estas instrucciones, podría resultar fatal para usted o para el vehículo.

## **INTRODUCCIÓN**

---

Este manual le provee de información de las características, instalación y funcionamiento de los amplificadores Rockford Fosgate 2.3, 2.6x y 4.6x. Le sugerimos guardar éste manual para futuras referencias.

Recomendamos que contacte con un distribuidor autorizado por Rockford Fosgate para la instalación de su nuevo Amplificador. Sin embargo, si decide instalar este amplificador usted mismo, asegúrese de leer todo el manual antes de empezar el montaje.

## **POSICIÓN DE MONTAJE**

---

### **Montaje en el maletero**

Montar el amplificador en una superficie vertical con las aletas o surcos en disposición vertical para obtener una mayor refrigeración del amplificador.

### **Montaje en el compartimento de los pasajeros**

Montar el amplificador requiere suficiente cantidad de aire para que el amplificador sea refrigerado correctamente. Si va usted a montar el amplificador bajo el asiento del vehículo, debe dejar como mínimo una distancia de 3cm para obtener una bolsa de aire suficiente que acepte la disipación del amplificador.

## **INSTALACIÓN**

---

- **Por seguridad**, desconecte el borne negativo de la batería antes de comenzar la instalación.

### **Terminal B+**

El cable B+ DEBE tener un fusible a 0,5 mts. o menos de la batería. Prepare los terminales de los cables e instale el soporte para el fusible. Las conexiones deben estar protegidas del agua.

### **Terminal de tierra**

Prepare longitud suficiente de cable para ser usado como conexión de tierra. Prepare al masa del chasis rascando pintura para que la superficie quede libre. Limpíela y conecte el cable a la toma de tierra con un tornillo.

### **Terminal REM**

Conecte el terminal REM a un terminal que determine cuando la fuente de sonido está en marcha. Si la fuente de sonido no tiene esta salida, la solución recomendada es conectar un interruptor mecánico a la fuente de 12 voltios para activar el amplificador.



## Funcionamiento Stereo/Mono

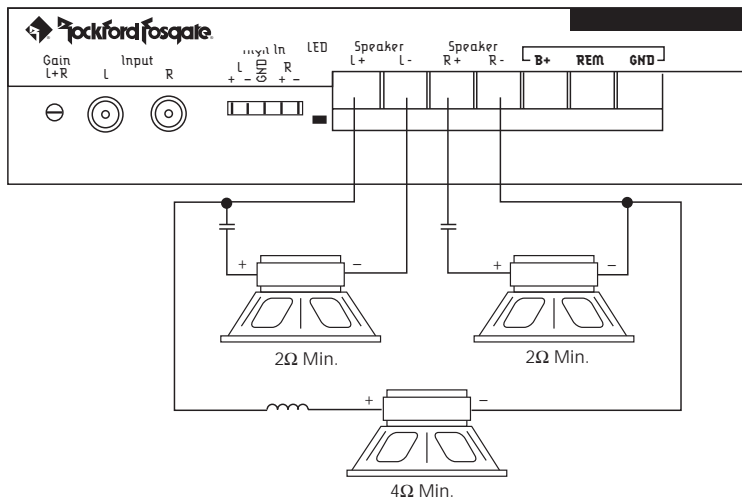

- Las entradas RCA están conectadas a ambas entradas, derecha e izquierda
- **Impedancia de carga** para cada canal estereo deben haber como minimo 2 Ohmios
- **Impedancia de carga** para un canal mono debe haber como minimo 4 Ohmios
- La XCard está colocada para obtener Full Range
- Los Crossovers Pasivos se necesitan para un funcionamiento correcto Stereo/Mono

## Funcionamiento con 4 canales Stereo

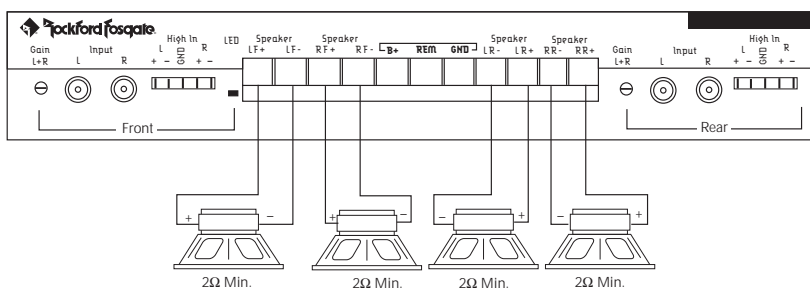

- Entradas RCA conectadas a todas las entradas
- **Control de ganancia** para que los canales frontal y posterior trabajen independientemente
- **Impedancia de carga** para cada canal estereo deben haber como minimo 2 Ohmios
- XCard Frontal puede ser colocada en Paso-altos, Paso-bajos o Full Range
- XCard Posterior puede ser colocada en Paso-altos, Paso-bajos o Full Range

## Funcionamiento con 4 canales Stereo y uno Mono

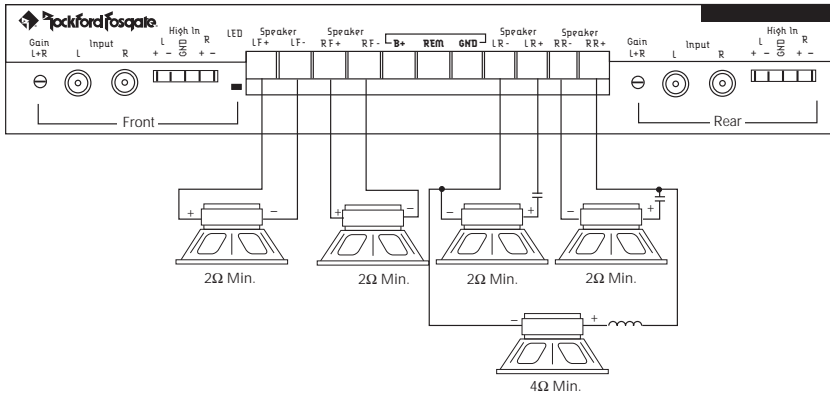

- **Entradas RCA** conectadas a todas las entradas
- **Control de ganancia** para que los canales frontal y posterior trabajen independientemente
- **Impedancia de carga** para cada canal estereo deben haber como mínimo 2 Ohmios
- **Impedancia de carga** para un canal mono debe haber como mínimo 4 Ohmios
- **XCard Frontal** puede ser colocada en Paso-altos, Paso-bajos o Full Range
- **XCard Posterior** puede ser colocada en Paso-altos, Paso-bajos o Full Range
- **Los Crossovers Pasivos** se necesitan para que los canales posteriores tengan un buen funcionamiento Stereo/Mono

Veillez lire les instructions suivantes relatives à l'installation de ces produits. Ne pas suivre ces instructions pourrait entraîner des dommages à vous-même ou à votre véhicule.

## INTRODUCTION

---

Ce manuel offre des informations sur les caractéristiques, l'installation et le fonctionnement des amplificateurs Rockford Fosgate 2.3, 2.6x et 4.6x. Nous vous proposons de conserver ce manuel pour toute référence future.

Nous vous recommandons vivement de faire installer votre nouvel amplificateur Rockford Fosgate auprès d'un installateur agréé Rockford Fosgate. Néanmoins, si vous décidez d'installer vous-même votre amplificateur, assurez-vous de lire l'entièreté de ce manuel avant de commencer.

## LOCALISATION DU MONTAGE

---

### Montage dans le coffre

Afin d'obtenir le meilleur refroidissement de l'amplificateur montez le verticalement de sorte que les stries soient verticales.

### Montage dans l'habitacle

Le montage de l'amplificateur dans l'habitacle est possible pour autant que l'amplificateur dispose d'une quantité d'air environnante suffisante à son refroidissement. Un espace d'air de minimum 2,5 cm est nécessaire tout autour de l'amplificateur.

## INSTALLATION

---

- **Par sécurité**, déconnecter la borne négative de la batterie avant de procéder à l'installation.

### Bornier B+

Le câble positif permanent (B+) DOIT être d'un fusible à moins de 50 cm de la borne de la batterie. Préparer les terminaisons du câble et installer le porte-fusible sous le capot. Les connections doivent être étanches.

### Bornier GND

Préparer un câble destiné à la connexion de la masse. Préparer la masse du châssis en enlevant toute peinture de la surface métallique et en la nettoyant et la dégraissant. Visser le câble de masse (GND) au châssis.

### Bornier REM

Connecter le fil REM à un positif commuté, habituellement pris sur la sortie antenne électrique ou accessoire de l'autoradio. Si l'autoradio n'est pas pourvu de l'une de ces sorties nous vous conseillons d'installer un commutateur séparé qui fournira du positif afin d'activer l'amplificateur.

## Installation stéréo/mono

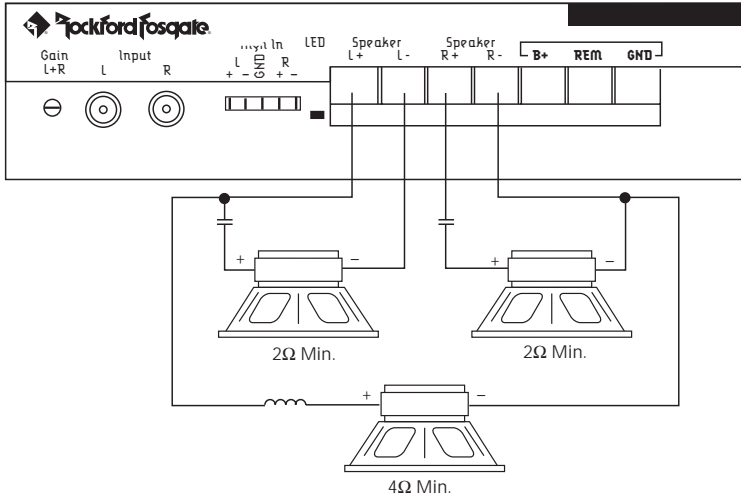

- l'entrée signal est connectée à l'entrée gauche et droite.
- la charge d'impédance pour chaque canal stéréo sera de 2Ω minimum
- la charge d'impédance pour le canal mono sera de 4Ω minimum
- la carte de filtrage sera installée en mode full range
- l'utilisation de filtres passifs est nécessaire pour un bon fonctionnement d'une installation stéréo/mono

## Installation 4 canaux stéréo

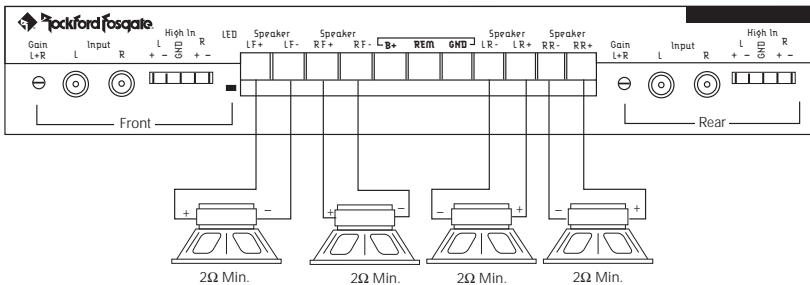

- les entrées signal sont connectées à toutes les entrées
- les contrôles de gain d'entrée avant et arrière sont réglés de manière indépendante
- la charge d'impédance pour chaque canal stéréo sera de 2Ω minimum
- la carte de filtrage avant peut être installée en mode passe-haut, passe-bas ou full range
- la carte de filtrage arrière peut être installée en mode passe-haut, pass-bas ou full range

## Installation 4 canaux stéréo/mono

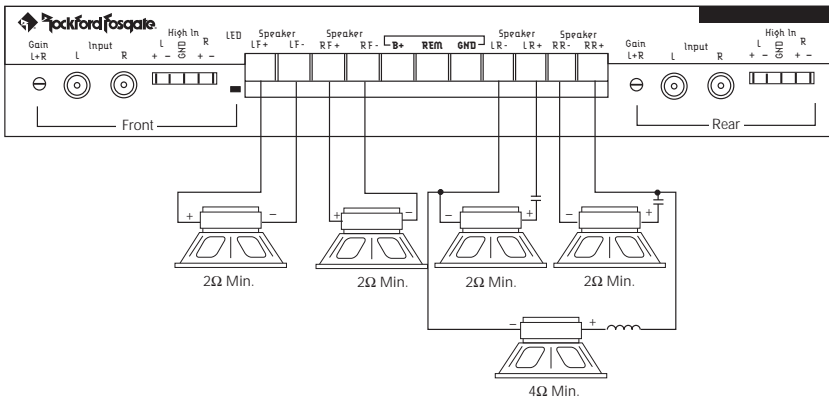

- les entrées signal sont connectées à toutes les entrées
- les contrôles de gain d'entrée avant & arrière sont réglés de manière indépendante
- la charge d'impédance pour chaque canal stéréo avant et arrière sera de 2Ω minimum
- la charge d'impédance pour le canal mono arrière sera de 4Ω minimum
- la carte de filtrage avant peut être installée en mode passe-haut, passe-bas ou full range
- la carte de filtrage arrière sera installée en mode full range
- l'utilisation de filtres passifs est nécessaire pour un bon fonctionnement d'une installation stéréo/mono

Bitte lesen Sie sich die folgende Bedienungsanleitung sorgfältig durch, dies kann Ihr Fahrzeug und das Produkt vor Beschädigung schützen.

## **EINLEITUNG**

---

Diese Bedienungsanleitung enthält Informationen über Features und den Einbau der Rockford Fosgate 2.3, 2.6x und 4.6 Verstärker. Wir empfehlen Ihnen diese Bedienungsanleitung sorgfältig aufzubewahren.

Wir raten Ihnen Ihren Verstärker nur von einem autorisierten Rockford Fosgate-Händler einbauen zu lassen, sollten Sie die Montage selber vornehmen, so lesen Sie sich diese Anleitung bitte sorgfältig durch.

## **EINBAUORT**

---

### **Kofferraum-Montage**

Eine vertikale Montage des Verstärkers im Kofferraum sichert die beste Kühlung des Verstärkers.

### **Montage im Fahrgastraum**

Die Montage auf der Beifahrerseite ist solange zu empfehlen, wie der Verstärker genug Luft zur Kühlung erhält. Sollten Sie den Verstärker unter dem Beifahrersitz montieren, stellen Sie bitte sicher, daß ein Luftspalt von 1" (2,5cm) zum Kühlkörper verbleibt.

## **MONTAGE**

---

- **Zur Sicherheit**, bitte klemmen Sie den Negativ-Pol der Batterie ab, bevor Sie mit dem Anschließen beginnen.

### **B+ Terminal**

Das Positiv-Kabel sollte nach wenigstens 18" (46cm), hinter dem Batterie-Pol abgesichert werden. Montieren Sie den Sicherungshalter in der Nähe der Batterie und stellen Sie sicher, daß alle Verbindungen wasserdicht sind.

### **GND Terminal**

Montieren Sie das Erdungskabel, indem Sie es an ein sauberes und lackfreies Metallstück, Ihres Fahrzeuges festschrauben. Versichern Sie sich, daß eine gute Verbindung des Kabels gewährleistet ist.

### **REM Terminal**

Verbinden Sie das REM-Terminal mit einer vom Radio kommenden Schallleitung, Sollte diese nicht vorhanden sein so empfehlen wir, durch ein geschaltetes 12 Volt Kabel den Verstärker ein-und auszuschalten.

## Mono/Stereo Betrieb

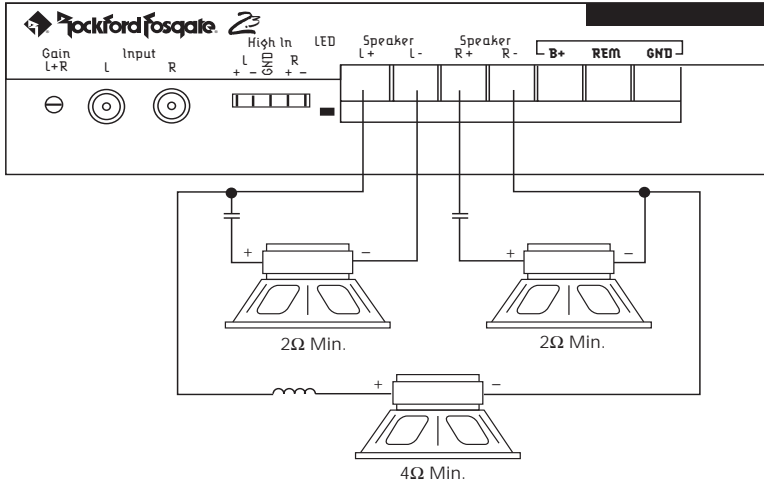

- RCA-Eingänge an den rechten und linken Eingangs-Buchsen verbinden
- Die Impedanz-Last für jeden Stereo Kanal sollte mindestens 2 Ohm betragen
- Die Impedanz-Last für den Mono Kanal sollte mindestens 4 Ohm betragen
- Die XCard sollte auf Full-Range stecken
- Eine Passiv-Weiche wird beim Stereo/Mono Betrieb benötigt

## 4-Kanal Stereo Betrieb

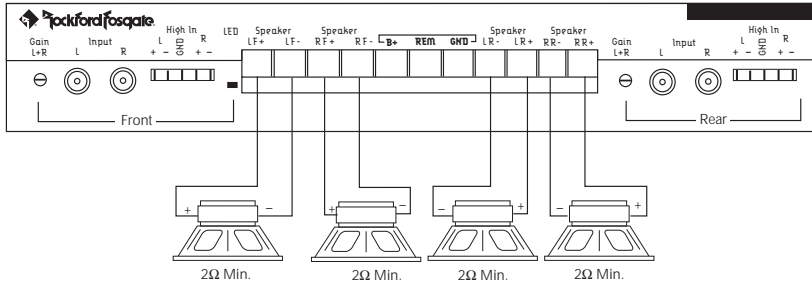

- RCA-Eingänge mit den Eingangs-Buchsen verbinden
- Gain-Regler für vorne und hinten arbeiten getrennt
- Die Impedanz-Last für jeden Stereo Kanal sollte mindestens 2 Ohm betragen
- Front XCard kann als Hoch-Pass, Tief-Pass oder Full-Range gesteckt werden
- Rear XCard kann als Hoch-Pass, Tief-Pass oder Full-Range gesteckt werden

## 4-Kanal Stereo/Single Betrieb

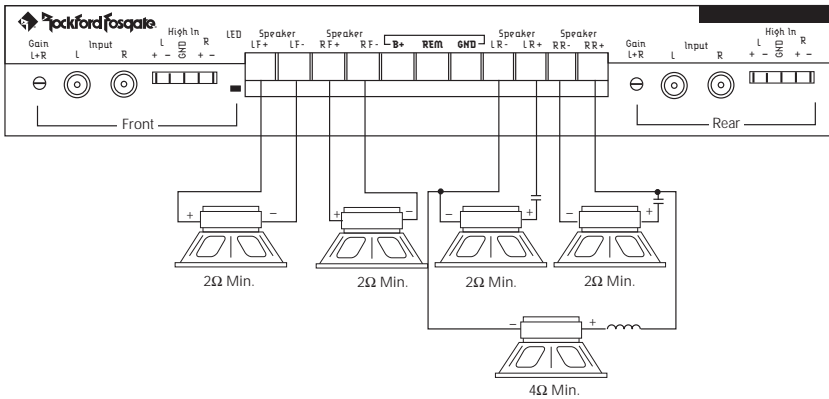

- **RCA-Eingänge** mit den Eingangs-Buchsen verbinden
- **Gain-Regler** für vorne und hinten arbeiten getrennt
- **Die Impedanz-Last** für die vorderen-und hinteren Stereo Kanäle sollte mindestens 2 Ohm betragen
- **Die Impedanz-Last** des hinteren Mono Kanal sollte mindestens 4 Ohm betragen
- **Front XCard** kann als Hoch-Pass, Tief-Pass oder Full-Range gesteckt werden
- **Rear XCard** sollte als Full-Range gesteckt werden
- **Passivweichen** sollten beim Stereo/Mono Betrieb verwendet werden



Leggere le seguenti istruzioni per l'installazione del prodotto. Evitare di seguire le istruzioni potrebbe risultare pericoloso per Voi e per il vostro veicolo.

## **INTRODUZIONE**

---

Questo manuale offre informazioni sulle caratteristiche, sull'installazione, e sul funzionamento degli amplificatori Rockford Fosgate 2.3, 2.6x e 4.6x. Vi suggeriamo di conservare questo manuale per riferimento futuro.

Noi raccomandiamo fortemente di far installare il vostro nuovo amplificatore da un installatore autorizzato. Se invece preferite installare da soli il vostro amplificatore, assicuratevi di leggere l'intero manuale prima di cominciare.

## **POSIZIONAMENTO**

---

### **Installazione nel bagagliaio**

Montare l'amplificatore su una superficie verticale con le alettature dall'alto al basso servirà a raffreddare meglio l'amplificatore.

### **Posizionamento nell'abitacolo**

L'amplificatore installato nell'abitacolo funzionerà se avrà a disposizione una quantità d'aria sufficiente per raffreddarlo. Se intendete montare l'amplificatore sotto un sedile del veicolo, è necessario avere al minimo una distanza di 2.5cm tra l'amplificatore e ciò che lo circonda.

## **INSTALLAZIONE**

---

- **Per ragioni di sicurezza**, disconnettere il cavo negativo dalla batteria prima di iniziare l'installazione.

### **Terminale B+ positivo**

La terminazione siglata B+ deve essere protetta da un fusibile posto a non più di 40cm dalla batteria del veicolo. Preparare il cavo ed installare il porta fusibile nel vano motore. I collegamenti devono essere a tenuta d'acqua.

### **Terminale GND Negativi**

Preparate uno spezzone di cavo per la massa. Preparate il punto di massa togliendo la vernice dalla superficie del metallo ed eliminando sporczia e grasso. Fissate il cavo al punto di massa impiegando un anello ed una vite.

### **Terminale REM Consenso**

Connettere il terminale REM ad un segnale proveniente dal cavo antenna elettrica o accessori dell'autoradio. In caso questo segnale non sia disponibile, la soluzione più raccomandata è di cablare un interruttore su una sorgente 12 volt permanente per attivare l'amplificatore.

## Funzionamento Stereo/Mono

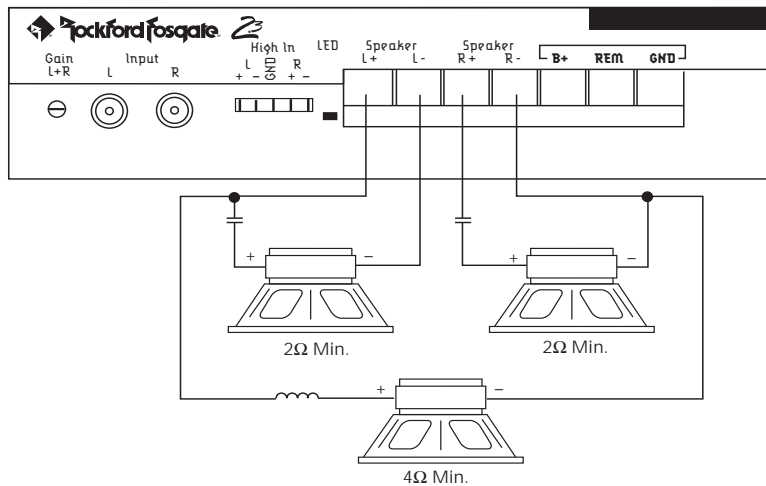

- Gli ingressi RCA sono collegati sia sull'ingresso *sinistro e destro*
- L'impedenza minima per ciascun canale stereo deve essere **2Ω**
- L'impedenza minima per il canale mono deve essere **4Ω**
- La XCard è posizionata in Full Range (gamma estesa)
- I crossover passivi sono indispensabili per il funzionamento stereo/mono simultaneo

## Funzionamento a 4 canali stereo

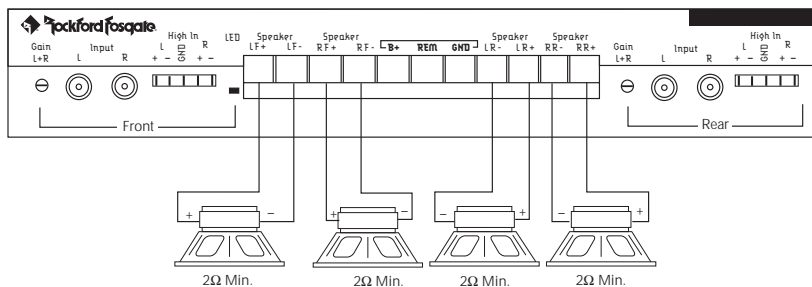

- Gli ingressi RCA sono collegati a *tutti* gli ingressi
- I controlli della sensibilità di ingresso anteriori e posteriori operano in modo *indipendente*
- L'impedenza minima per ciascun canale stereo deve essere **2Ω**
- La XCard anteriore può essere posizionata High-Pass (passa alto), Low-Pass (passa basso) o Full Range (gamma estesa)
- La XCard posteriore può essere posizionata High-Pass (passa alto), Low-Pass (passa basso) o Full Range (gamma estesa)

## Funzionamento a 4 canali stereo con mono simultaneo

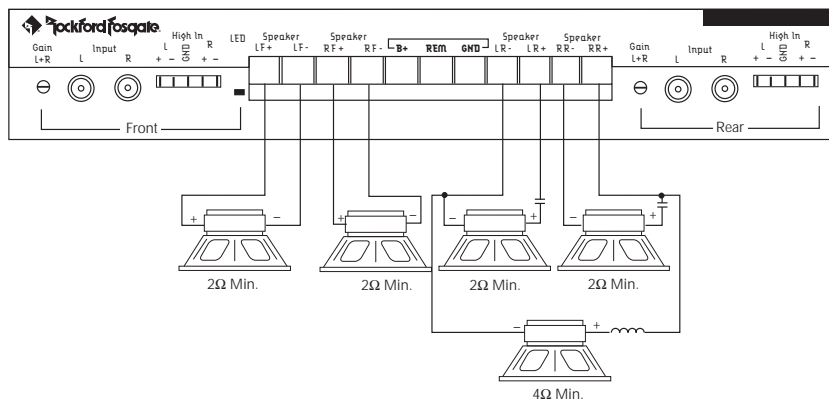

- Gli ingressi RCA sono collegati a tutti gli ingressi
- I controlli della sensibilità di ingresso anteriori & posteriori operano in modo indipendente
- L'impedenza minima per ciascun canale stereo deve essere  $2\Omega$
- L'impedenza minima per il canale mono posteriore deve essere  $4\Omega$
- La XCard anteriore può essere posizionata High-Pass (passa alto), Low-Pass (passa basso) o Full Range (gamma estesa)
- La XCard posteriore deve essere posizionata Full Range (gamma estesa)
- I crossover passivi sono indispensabili per il funzionamento stereo/mono simultaneo

## MADE IN THE USA

This product is designed, developed and assembled in the USA by a dedicated group of American workers. The majority of the components used in the construction of this product are produced by American companies. However, due to the global nature of their manufacturing facilities and the electronics parts industry in general, some parts may be manufactured in other countries.

### **Rockford Fosgate**

Rockford Corporation  
546 South Rockford Drive  
Tempe, Arizona 85281 U.S.A.  
In U.S.A., (602) 967-3565  
In Europe, Fax (49) 4202-9750-0  
In Japan, Fax (81) 559-79-1265