

— Installation assistance available at: —  
**RFTECH**  
— [www.rockfordfosgate.com/rftech](http://www.rockfordfosgate.com/rftech) —

**POLARIS® GENERAL®  
REAR SPEAKER  
WIRE KIT**

**RFGNRL-RSW16**

600 South Rockford Drive • Tempe, Arizona 85281 United States  
Direct: (480) 967-3565 • Toll Free: (800) 669-9899

**ROCKFORDFOSGATE.COM**



# Introduction

Dear Customer,

Congratulations on your purchase of the world's finest brand of audio products. At Rockford Fosgate we are fanatics about musical reproduction at its best, and we are pleased you chose our product. Through years of engineering expertise, hand craftsmanship and critical testing procedures, we have created a wide range of products that reproduce music with all the clarity and richness you deserve.

For maximum performance we recommend you have your new Rockford Fosgate product installed by an Authorized Rockford Fosgate Dealer, as we provide specialized training through Rockford Technical Training Institute (RTTI). Please read your warranty and retain your receipt and original carton for possible future use.

Great product and competent installations are only a piece of the puzzle when it comes to your system. Make sure that your installer is using 100% authentic installation accessories from Rockford Fosgate in your installation. Rockford Fosgate has everything from RCA cables and speaker wire to power wire and battery connectors. Insist on it! After all, your new system deserves nothing but the best.

To add the finishing touch to your new Rockford Fosgate image order your Rockford accessories, which include everything from T-shirts to hats.

Visit our web site for the latest information on all Rockford products;

**[www.rockfordfosgate.com](http://www.rockfordfosgate.com)**

or, in the U.S. call 1-800-669-9899 or FAX 1-800-398-3985. For all other countries, call +001-480-967-3565 or FAX +001-480-966-3983.

## Table of Contents

2	Introduction
3	Installation
4	Warranty

If, after reading your manual, you still have questions regarding this product, we recommend that you see your Rockford Fosgate dealer. If you need further assistance, you can call us direct at **1-800-669-9899**. Be sure to have your serial number, model number and date of purchase available when you call.

## PRACTICE SAFE SOUND

Continuous exposure to sound pressure levels over 100dB may cause permanent hearing loss. High powered auto sound systems may produce sound pressure levels well over 130dB. Use common sense and practice safe sound.

## Safety

This symbol with "WARNING" is intended to alert the user to the presence of important instructions. Failure to heed the instructions will result in severe injury or death.



This symbol with "CAUTION" is intended to alert the user to the presence of important instructions. Failure to heed the instructions can result in injury or unit damage.



- To prevent injury and damage to the unit, please read and follow the instructions in this manual. We want you to enjoy this system, not get a headache.
- If you feel unsure about installing this system yourself, have it installed by a qualified Rockford Fosgate technician.
- Before installation, disconnect the battery negative (-) terminal to prevent damage to the unit, fire and/or possible injury.

## Contents

- (1) Driver's Side Wire Harness
- Plastic Wire Tie Wraps
- (1) Passenger Side Wire Harness

## Installation Tools

The following is a list of suggested tools needed for installation:

- Small Flat Blade Screwdriver
- Wire Cutters
- T-40 Torx
- Panel Tool
- 4mm Allen Driver

## Installation Considerations

This section focuses on some considerations for installing your Polaris GENERAL rear speaker wire kit. This wire kit is designed to work in conjunction with Rockford's other GENERAL specific audio kits and parts.

If you feel unsure about installing this system yourself, have it installed by a qualified technician.

When drilling holes, make sure you know what is on the other side. Be sure that any electrical, fuel lines or any other important components are free and clear from the area.

### **WARNING**

Before installation, disconnect the battery negative (-) terminal to prevent damage to the unit, fire and/or possible injury.

### **CAUTION**

Before beginning any installation, follow these simple rules:

### **CAUTION**

Be sure to carefully read and understand the instructions before attempting to install this wiring kit.

- Consult your UTV's service manual for model specific information. Models may differ from year to year depending on factory options and aftermarket accessories added.
- This rear speaker wire kit is specifically designed to work with Rockford Fosgate's GENERAL audio kits.
- With the addition of an amplifier or source unit, be sure that your current charging system is in proper working order.
- Visit [rockfordfosgate.com](http://rockfordfosgate.com) for more comprehensive product information.
- Visit our **YouTube** channel for comprehensive installation videos demonstrating complete installation guides and install tips.

## NEED HELP WITH YOUR INSTALLATION?



**YOUTUBE** VISIT OUR CHANNEL FOR A COMPLETE INSTALLATION VIDEO AND OTHER TIPS  
[WWW.YOUTUBE.COM/USER/ROCKFORDFOSGATE](http://WWW.YOUTUBE.COM/USER/ROCKFORDFOSGATE)

### Applicable Models:

#### Polaris GENERAL 1000 (2 & 4 seat models)

This rear speaker wire kit is designed to work with Rockford Fosgate's RFGNRL-K8 amplifier kit and RFGNRL-PMXDK dash kit. The wire kit can be installed in both 2-seat and 4-seat models secured to the roll cage and run under the floor.

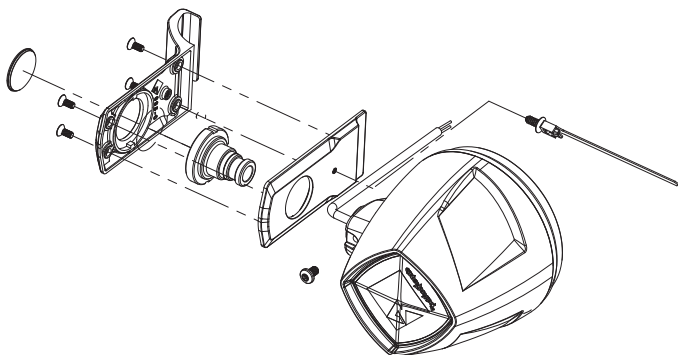

- Step 1. Once the PM-CL3B clamps are secured to the roll cage, feed the 2-pin white connector through the front hole of the mounting flange exiting the other side of the clamp assembly.

NOTE: The white connector with the red dot denotes the passenger side cable. Pay attention when installing your wire harnesses to observe proper polarity.

- Step 2. After pulling sufficient slack through, then pass the two pin connector back through the mounting flange through the center hole where the speaker will be mounted leaving a loop of cable on the outside of the clamp assembly (Fig. A).

- Step 3. Connect the 2-pin connector to the mating connector found on top of the wake can assembly and feed the excess cable back through as you mount the can to the mounting flange. (Fig. B)

- Step 4. Once the can is secure, feed the remaining loop of wire back through the front of the mounting flange and secure with the supplied wire tie. Affix the provided adhesive backed logo disk to the clamp to fill the wiring access hole.

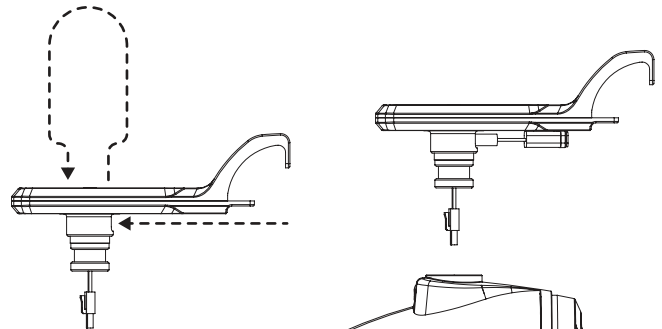

**A - Insert wire harness**

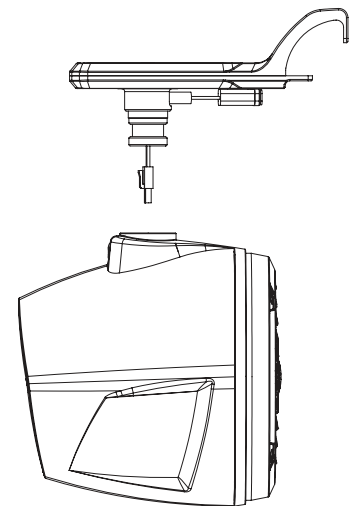

**B - Connect wire to speaker**

- Step 5. Remove the hardware holding the rear cab trim panels, under seat storage bins, center line driveshaft cover, hood and dash top trim panel allowing access to run the cables forward.

- Step 6. Route the harness down the back of the cab, under the trim panels coming up underneath the seat. Direct the wire to the center of the vehicle and pass it forward along the centerline of the vehicle following the main wire harness.

NOTE: If installing into a 4-seat model, you will need to pass the cables from the rear seat to the front seat through the wire tunnel. Enough cable length has been provided for this.

- Step 7. Pass the harness through into the front passenger wheel well area from the inside of the vehicle, up along the shock assembly through the molded oval opening into the hood area.

- Step 8. Feed the harness through the firewall grommet and connect to either the radio or amplifier speaker harness located in the dash.

- Step 9. Test the system and once verified, wire tie the cables starting at the rear pulling any slack forward as you go.

NOTE: When securing the wire in the wheel well area, keep cables as far from the shock assembly as possible to avoid possible damage.

- Step 10. Reassemble the vehicle

# Warranty

---

## **Rockford Corporation offers a limited warranty on Rockford Fosgate products on the following terms:**

### **Length of Warranty**

POWER Amplifiers – 2 Years

BMW® Direct Fit Speakers – 2 Years

PUNCH® & PRIME® Amplifiers – 1 Year

Speakers, Signal Processors, Accessories and Capacitors – 1 Year

All marine, motorcycle, motorsport products - 2 Years

Any Factory Refurbished Product – 90 Days (receipt required)

### **What is Covered**

This warranty applies only to Rockford Fosgate products sold to consumers by authorized Rockford Fosgate dealers in the United States of America. Products purchased by consumers from an Authorized Rockford Fosgate Dealer in another country are covered only by that country's Distributor and not by Rockford Corporation.

### **Who is Covered**

This warranty covers only the original purchaser of Rockford product purchased from an authorized Rockford Fosgate dealer in the United States. In order to receive service, the purchaser must provide Rockford with a copy of the receipt stating the customer name, dealer name, product purchased and date of purchase.

Products found to be defective during the warranty period will be repaired or replaced (with a product deemed to be equivalent) at Rockford's discretion.

### **What is Not Covered**

1. Damage caused by accident, abuse, improper installation, operations, theft, water (on non-Element Ready products).
2. Any cost or expense related to the removal or reinstallation of product.
3. Service performed by anyone other than Rockford or an authorized Rockford Fosgate service center.
4. Any product which has had the serial number defaced, altered, or removed.
5. Subsequent damage to other components.
6. Any product purchased outside the U.S.
7. Any product not purchased from an authorized Rockford Fosgate dealer. Refer to [rockfordfosgate.com](http://rockfordfosgate.com) dealer locator for more detail.

### **Limit on Implied Warranties**

Any implied warranties including warranties of fitness for use and merchantability are limited in duration to the period of the express warranty set forth above. Some states do not allow limitations on the length of an implied warranty, so this limitation may not apply. No person is authorized to assume for Rockford Fosgate any other liability in connection with the sale of the product.

### **How to Obtain Service**

Please call 1-800-669-9899 for Rockford Customer Service. You must obtain an RA# (Return Authorization number) to return any product to Rockford Fosgate. You are responsible for shipment of product to Rockford.

### **EU Warranty**

This product meets the current EU warranty requirements, see your Authorized dealer for details.