



RFP2408/2808

RFP2410/2810

RFP2412/2812

RFP2415/2815

RFP2418/2818

punch



Dear Customer,

Congratulations on your purchase of the world's finest brand of car audio speakers. At Rockford Fosgate we are fanatics about musical reproduction at its best, and we are pleased you chose our product. Through years of engineering expertise, hand craftsmanship and critical testing procedures, we have created a wide range of products that reproduce music with all the clarity and richness you deserve.

For maximum performance we recommend you have your new Rockford Fosgate product installed by an Authorized Rockford Fosgate Dealer, as we provide specialized training through Rockford Technical Training Institute (RTTI). Please read your warranty and retain your receipt and original carton for possible future use.

Great product and competent installations are only a piece of the puzzle when it comes to your system. Make sure that your installer is using 100% authentic installation accessories from Connecting Punch in your installation. Connecting Punch has everything from RCA cables and speaker wire to Power line and battery connectors. Insist on it! After all, your new system deserves nothing but the best.

To add the finishing touch to your new Rockford Fosgate image order your Rockford wearables, which include everything from T-shirts and jackets to hats and sunglasses.

To get a free brochure on Rockford Fosgate products and Rockford wearables, in the U.S. call 602-967-3565 or FAX 602-967-8132. For all other countries, call +001-602-967-3565 or FAX +001-602-967-8132.

PRACTICE SAFE SOUND™

CONTINUOUS EXPOSURE TO SOUND PRESSURE LEVELS OVER 100dB MAY CAUSE PERMANENT HEARING LOSS. HIGH POWERED AUTOSOUND SYSTEMS MAY PRODUCE SOUND PRESSURE LEVELS WELL OVER 130dB. USE COMMON SENSE AND PRACTICE SAFE SOUND.

If, after reading your manual, you still have questions regarding this product, we recommend that you see your Rockford Fosgate dealer. If you need further assistance, you can call us direct at 1-800-669-9899. Be sure to have your serial number, model number and date of purchase available when you call.

The serial number can be found on the outside of the box. Please record it in the space provided below as your permanent record. This will serve as verification of your factory warranty and may become useful in recovering your speaker if it is ever stolen.

Serial Number: _____

Model Number: _____

TABLE OF CONTENTS

Introduction	1
RF Punch XLC Woofer Contents	1
Technical Design Features	1
Stamped Basket	1
PVA Cone	1
Inverted Dust Cap	1
Aluminum Voice Coil Former	2
Progressive Dual Laminated Spider	2
Dual Laminated Foam Surrounds	2
Hyper-Extended Pole Piece	2
Vented Bumped Back Plate	2
Installation	3
Recommended Enclosures	3
Building An Enclosure	5
Calculating Volume	5
Subwoofer Crossovers	5
Wiring Configurations	6
Specifications	7
Warranty Information	8
International Information	9

GETTING STARTED

Welcome to Rockford Fosgate! This manual is designed to provide information for the owner, salesperson and installer. For those of you who want quick information on how to install this product, please turn to the **Installation Section** of this manual or refer to the icon listed below. Other information can be located by using the Table of Contents. We, at Rockford Fosgate, have worked very hard to make sure all the information in this manual is current. But, as we are constantly finding new ways to improve our product, this information is subject to change without notice.



Sections marked **INSTALLATION** include "slam dunk" assembly and wiring directions

INTRODUCTION

The RF Punch XLC Woofers are a full line of low frequency drivers sized from 8" to 18" and are available in 4 or 8 ohm impedance. **The RF Punch XLC woofers were designed for use primarily in small, sealed or ported enclosures.** By utilizing the latest materials and construction techniques, we are able to offer a speaker with high output at low frequencies while requiring a minimum of operating space.

RF PUNCH WOOFER CONTENTS

RF Punch XLC Woofer
Installation & Owner's Manual
4 Foam Gaskets

TECHNICAL DESIGN FEATURES

◆ Stamped Basket

The RF Punch XLC Woofers use a stamped Cold Rolled Steel basket which is rigid and lightweight. The basket is finished in a corrosive resistant powder coated process used in many automotive applications.

THE RESULT: A lightweight and rigid woofer

◆ PVA Cone

The cone material used is spruce pulp paper. This provides the necessary combination of weight and strength and allows high levels of output without cone break up. The cone is treated with a water resistant PolyVinyl Acetate (PVA) Emulsion which increases the cone rigidity and lowers distortion.

THE RESULT: Increases cone rigidity and lowers distortion

◆ Inverted Dust Cap

The use of the inverted dust cap serves to increase the cone rigidity and improve the power handling by forcing more air through the voice coil.

THE RESULT: Increases cone rigidity, smooths frequency response and prevents your friends from feeling obligated to invert them for you.

◆ Aluminum Voice Coil Former

The voice coil former is black, anodized aluminum for highly efficient thermal transfer. This allows winding high temperature copper wire in multiple layers for improved efficiency.

THE RESULT: Improves power handling by efficiently dissipating heat

◆ Flat Progressive Dual Laminated Spider

A flat progressive dual laminated spider is employed to provide stronger suspension for the woofer. A secondary spider is fused to the primary spider near the critical voice coil bonding point. The combination of these two spiders, in addition to the progressive rolls, provides the ultimate in linear control for high excursion capability.

THE RESULT: Strengthens suspension for higher excursion capability

◆ Dual Laminated Foam Surrounds

The RF Punch XLC Woofers employ a dual laminated foam surround for the front of the woofer's suspension. Dual lamination improves reliability by making the woofer mechanically stronger.

THE RESULT: Adds mechanical strength

◆ Hyper-Extended Pole Piece

The pole piece has been extended to provide a more linear magnetic field for the operation of the woofer. This lowers distortion and provides the woofer with better low frequency response.

THE RESULT: Lowers distortion and provides better low frequency response

◆ Vented Bumped Back Plate

The back plate has been stepped deeper to allow the woofer more excursion without bottoming out. This enables the speaker to be used in a smaller enclosure. Additionally, the back plate is vented with a radiused aerodynamic back vent which efficiently and quietly circulates cool air around the voice coil.

THE RESULT: More excursion and increased power handling

INSTALLATION



Punch 8" Recommended Enclosures

Recommended Sealed .30ft³ (8.50L)

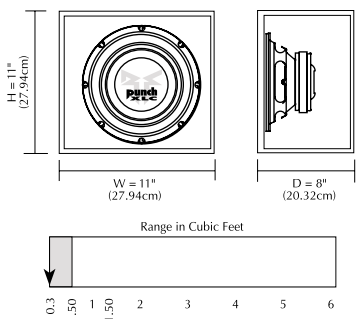

Recommended Ported .625ft³ (17.70L)

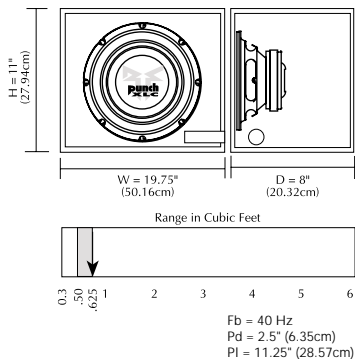

Punch 10"

Recommended Sealed .75ft³ (21.24L)

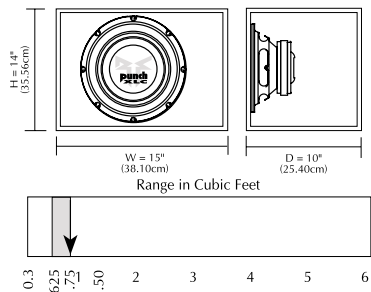

Recommended Ported 1.0 ft³ (28.32L)

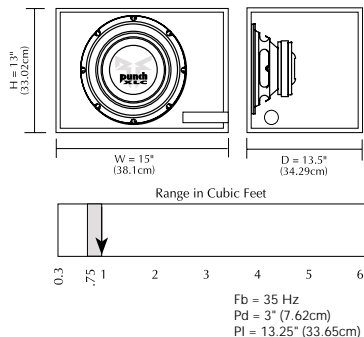

Punch 12"

Recommended Sealed 1.25ft³ (35.40L)

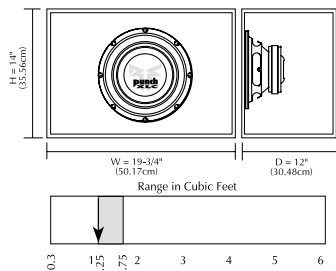

Recommended Ported 2.0 ft³ (56.63L)

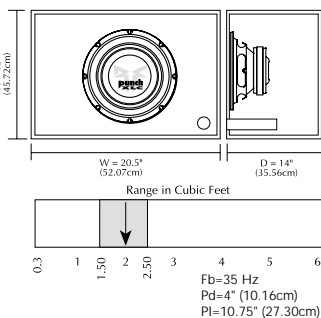



Punch 15"

Recommended Enclosures

Recommended Sealed 2.5ft³ (70.79L)

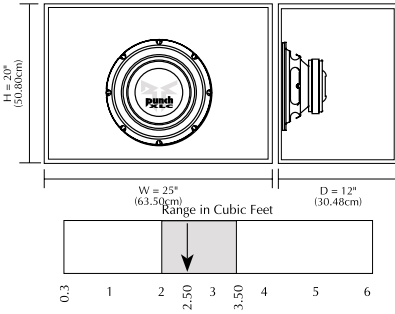

Recommended Ported 2.5ft³ (70.79L)

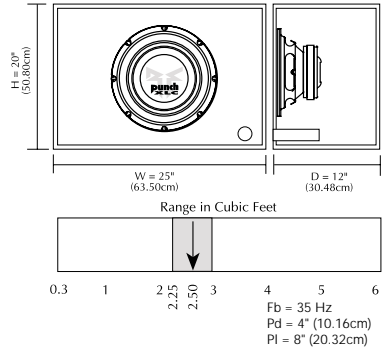

Punch 18"

Recommended Sealed 4.0ft³ (113.27L)

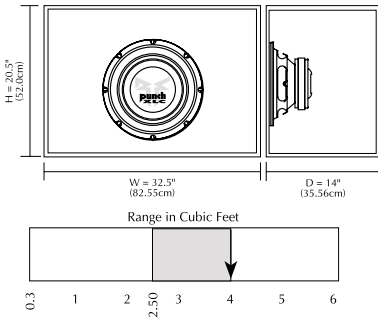

Recommended Ported 4.0ft³ (113.27L)

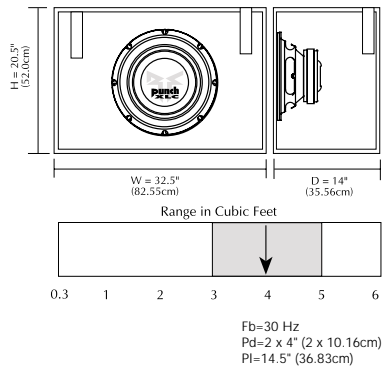

Building an Enclosure

To work properly, the walls of the enclosure must be rigid and not flex when subjected to the high pressures generated by the speaker's operation. For optimum performance, we recommend using 3/4" MDF (Medium Density Fiberboard) and internal bracing. The enclosure should be glued together and secured with nails or screws. MDF is porous; therefore, it is suggested to also seal the outside walls with polyurethane.

Calculating Volume

Calculating volume is merely a matter of measuring the dimensions in inches and using the formula:

$$\text{Box Volume} = \frac{\text{Height x Width x Depth}}{1728}$$

(cubic feet)

If two facing sides are of uneven length, add them together and divide by two to take the average. Using this number will give you the volume without the necessity of calculating the box in sections and adding the sections together. The thickness of the baffle material reduces the internal volume so this must be subtracted from the outside dimensions to determine the internal volume. The speaker itself also reduces the internal volume. The amount of air displaced by each model is listed on the specification sheet and should also be subtracted from the gross volume calculation.

Subwoofer Crossovers

There are two operational types of crossovers, passive and active. Passive crossovers (coils or inductors) are placed on the speaker leads between the amplifier and speaker. An active crossover is an electronic filter which separates the audio signal fed to different amplifiers. *For optimum subwoofer performance, we recommend using an active 80-100Hz low-pass crossover at 12dB/octave.*



Wiring Configurations

Three configurations for connecting speakers to an amplifier are **Series**, **Parallel**, and **Series-Parallel** wiring. A Series configuration consists of two or more speakers wired in a string (end to end). A Parallel configuration consists of two or more speakers wired with the common terminals connected across each other. A Series-Parallel configuration is a combination of both methods. Determine which method will be compatible with your amplifier.

Series Wiring

$$R_T = R_1 + R_2 + R_3 + \text{etc.}$$

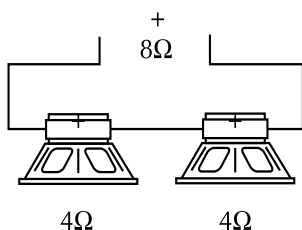

Parallel Wiring

$$\frac{1}{R_T} = \frac{1}{R_1} + \frac{1}{R_2} + \frac{1}{R_3} + \frac{1}{R_4} + \text{etc.}$$

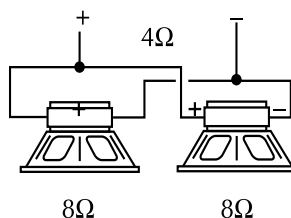

Series-Parallel Wiring

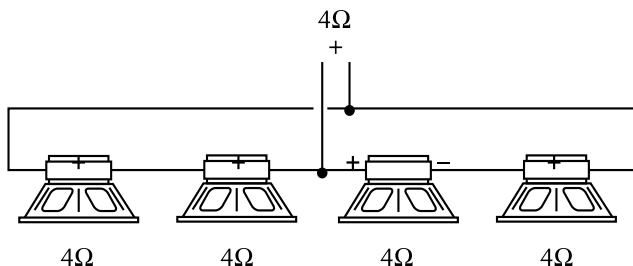

- R_T indicates the total speaker load
- $R_1, R_2, \text{etc.}$ indicates each speaker in the system
- **Red dot** indicates "+" terminal of 8 ohm speaker
- **Purple dot** indicates "+" terminal of 4 ohm speaker

SPECIFICATIONS

Model	RFP2408	RFP2808	RFP2410	RFP2810	RFP2412	RFP2812	RFP2415	RFP2815	RFP2418	RFP2818
Nominal Impedance	4	8	4	8	4	8	4	8	4	8
FS (Hz)	35	37	30	32	28	30	23	25	22	24
RE (Ohm)	3.7	7.3	3.7	7.3	3.7	7.3	3.7	7.3	3.9	7.8
LE (mH)	3.3	5.2	3.3	5.2	3.3	5.2	3.3	5.2	3.8	6.7
OMS	6.18	6.63	5.38	5.23	6.20	5.91	5.51	5.50	5.25	5.70
OES	0.39	0.50	0.39	0.47	0.52	0.71	0.42	0.55	0.49	0.575
OTS	0.37	0.47	0.36	0.43	0.48	0.64	0.39	0.50	0.46	0.522
VAS (cu.ft.)	0.635	0.635	1.62	1.62	4.23	4.23	11.86	11.86	14.44	14.44
VAS (liter)	18	18	46	46	120	120	336	336	409	409
Power (Watts RMS)	200	200	200	200	200	200	200	200	250	250
Power (Watts Peak)	400	400	400	400	400	400	400	400	500	500
SPL (dB @ 1w/1m)	85	85	87	87	89	89	92	92	92	92
X-MAX (inches)	0.31	0.31	0.31	0.31	0.31	0.31	0.31	0.31	0.39	0.39
X-MAX (mm)	8	8	8	8	8	8	8	8	10	10
Sealed Box Vol. (cu. ft.)	0.3	0.3	0.75	0.75	1.25	1.25	2.5	2.5	4.0	4.0
Ported Box Vol. (cu. ft.)	0.625	0.625	1.0	1.0	2.0	2.0	2.5	2.5	4.0	4.0
Speaker Dis. (cu. ft.)	0.05	0.05	0.06	0.06	0.09	0.09	0.113	0.113	0.19	0.19
Mounting Dia. (in.)	7 ¹ / ₁₆	7 ¹ / ₁₆	9 ⁵ / ₃₂	9 ⁵ / ₃₂	11	11	14	14	16 ¹⁹ / ₃₂	16 ¹⁹ / ₃₂
Mounting Depth (in.)	3 ¹³ / ₁₆	3 ¹³ / ₁₆	4 ¹ / ₂	4 ¹ / ₂	5 ³ / ₈	5 ³ / ₈	7 ¹ / ₈	7 ¹ / ₈	8 ¹ / ₂	8 ¹ / ₂



LIMITED WARRANTY INFORMATION

Rockford Corporation offers a limited warranty on Rockford Fosgate products on the following terms:

- **Length of Warranty**

1 year on speakers	30 days on speaker B-stock (receipt required)
3 years on electronics	90 days on electronic B-stock (receipt required)
2 years on source units	

- **What is Covered**

This warranty applies only to Rockford Fosgate products sold to consumers by Authorized Rockford Fosgate Dealers in the United States of America or its possessions. Product purchased by consumers from an Authorized Rockford Fosgate Dealer in another country are covered only by that country's Distributor and not by Rockford Corporation.

- **Who is Covered**

This warranty covers only the original purchaser of Rockford product purchased from an Authorized Rockford Fosgate Dealer in the United States. In order to receive service, the purchaser must provide Rockford with a copy of the receipt stating the customer name, dealer name, product purchased and date of purchase.

- **Products found to be defective** during the warranty period will be repaired or replaced (with a product deemed to be equivalent) at Rockford's discretion.

- **What is Not Covered**

1. Damage caused by accident, abuse, improper operations, water, theft
2. Any cost or expense related to the removal or reinstallation of product
3. Service performed by anyone other than Rockford or an Authorized Rockford Fosgate Service Center
4. Any product which has had the serial number defaced, altered, or removed
5. Subsequent damage to other components
6. Any product purchased outside the U.S.
7. Any product not purchased from an Authorized Rockford Fosgate Dealer

- **Limit on Implied Warranties**

Any implied warranties including warranties of fitness for use and merchantability are limited in duration to the period of the express warranty set forth above. Some states do not allow limitations on the length of an implied warranty, so this limitation may not apply. No person is authorized to assume for Rockford Fosgate any other liability in connection with the sale of the product.

- **How to Obtain Service**

Please call 1-800-669-9899 for Rockford Customer Service. You must obtain an RA# (Return Authorization number) to return any product to Rockford Fosgate. You are responsible for shipment of product to Rockford.

Ship to: **Electronics**
Rockford Corporation
Warranty Repair Department
2055 E. 5th Street
Tempe, AZ 85281
RA#: _____

Ship to: **Speakers**
Rockford Acoustic Design
(Receiving-speakers)
609 Myrtle N.W.
Grand Rapids, MI 49504
RA#: _____



LEA DETENIDAMENTE LAS SIGUIENTES INSTRUCCIONES DE INSTALACIÓN DEL PRODUCTO.

INTRODUCCIÓN

Los woofers RF Punch XLC son una gama completa de drivers de baja frecuencia que comprenden diámetros de 8" a 15". Los Woofers RF Punch XLC fueron diseñados para su utilización en caja cerrada o bass-reflex mediana. Diseñada para ofrecer la máxima calidad, los Woofers RF ofrecen al entusiasta principiante en sistemas de car audio, la oportunidad para disfrutar de un bajo sólido en las bajas frecuencias. Nuestros ingenieros han seleccionado materiales y técnicas para la construcción de nuestros altavoces con el objetivo de ofrecer características y confianza comparable a otros altavoces vendidos much más caros.

TERMINALES DE ENTRADA

Los terminales positivo y negativo de entrada están ubicados uno en cada extremo de la carcasa. Este montaje separado previene de posibles cortocircuitos de la señal a altos niveles de volumen. El terminal positivo está marcado con un punto en la carcasa. Un punto rojo indica que la impedancia del altavoz es de 8 ohmios, y un punto violeta que es de 4 ohmios.

CALCULO DEL VOLUMEN

Para calcular el volumen sólo se han de medir las dimensiones en centímetros y aplicar la fórmula:

Volumen de la caja = (en litros)	$\frac{\text{Alto} \times \text{Ancho} \times \text{Profundidad}}{1000}$
--	--

Si dos caras opuestas son de diferente tamaño, súmelas y divida el total por dos para obtener el promedio. Usando esta técnica se ahorra el cálculo por secciones. El espesor del material con que está construida la caja reduce el volumen interno, de manera que ha de restarse de las dimensiones exteriores para determinar el volumen interior. La cantidad de aire que ocupa cada modelo viene especificado en la hoja de características y también debe sustraerse para obtener el volumen neto interior.

CONSTRUCCION DE UN RECINTO

Para un buen funcionamiento las paredes del recinto han de ser rígidas y sin flexión a altas presiones de aire. Recomendamos usar un espesor de 1.9 cm de conglomerado de alta densidad o fibra de media densidad. Si el recinto es muy grande es necesario reforzarlo internamente. Las juntas deben ser encoladas y aseguradas con tornillos o grapas. Internamente las juntas deben ser selladas con silicona para prevenir las fugas de aire. La cola para madera es la mejor opción. Debido a la porosidad del conglomerado de alta densidad y la fibra es recomendable sellar exteriormente la caja con poliuretano.

VEUILLEZ LIRE LES INSTRUCTIONS SUIVANTES POUR L'INSTALLATION DE CE PRODUIT.

INTRODUCTION

Les woofers RF Punch XLC sont une gamme complète de haut-parleurs de graves allant de 20 à 46 cm et disponibles en 4Ω ou 8Ω . **Les woofer RF Punch XLC ont été conçus pour être utilisés de préférence en enceintes closes.**

En utilisant les techniques et les matériaux de construction les plus récents, nous sommes parvenus à construire un haut-parleur fournissant un rendement élevé dans les graves tout en requérant un volume opérationnel minimum.

BORNIERS

Les bornes positives et négatives sont fixées de part et d'autre du saladier. Cette séparation permet d'empêcher les courts-circuits entre les fils lors des reproductions sonores élevées. **La borne positive est repérée par un petit point de couleur sur le saladier.** Un point rouge est utilisé pour les haut-parleurs de 8Ω , un point violet pour les haut-parleurs de 4Ω .

CALCUL DU VOLUME

On calcule le volume en mesurant la dimension de chaque côté et en utilisant la formule suivante:

Volume du caisson = (Litres)	Hauteur (cm) x Longueur (cm) x Largeur (cm)
	1000

Si les deux côtés qui se font face n'ont pas la même longueur, additionnez les et divisez le résultat par deux pour obtenir la moyenne des deux longueurs. Utilisez le nombre ainsi obtenu dans la formule pour déterminer le litrage. Cette méthode permet d'obtenir le volume du caisson sans devoir faire de calculs compliqués de section de volume. L'épaisseur du matériau dont est fait le caisson réduit le volume interne de celui-ci. Lorsqu'on mesure les côtés du caisson il ne faut donc pas oublier d'oter des mesures l'épaisseur du matériau. Le haut-parleur lui-même diminue le volume interne du caisson. Le volume d'air déplacé par chaque modèle de haut-parleur est repris dans les spécifications techniques et doit également être soustrait du volume total.

FRANCAIS

CONSTRUIRE UN CAISSON

Pour fonctionner convenablement les parois du caisson doivent être rigides lorsqu'elles sont soumises aux hautes pressions dues au fonctionnement du haut-parleur. Nous vous recommandons d'utiliser des panneaux de bois aggloméré à haute ou moyenne densité de particules de type "MDF". Ces panneaux sont disponibles dans la plupart des magasins de bricolage. Pour un caisson de grand volume il est recommandé de placer des renforts à l'intérieur du caisson. Les différents côtés devront être collés (colle à bois) et vissés (ou éventuellement cloués). Il est recommandé de mettre un joint de silicone dans les arêtes internes du caisson afin d'éviter les fuites d'air. Du fait de la porosité des matériaux que nous vous conseillons il est préférable de recouvrir l'extérieur du caisson avec du polyuréthane.

BITTE LESEN SIE DIESE GEBRAUCHSANLEITUNG ZUERST SORGFÄLTIG DURCH. DAS KANN SIE VOR FALSCHEM EINSATZ, AUSFALLEN ODER SOGAR BESCHÄDIGUNG DES PRODUKTES ODER IHRES FAHRZEUGES SCHÜTZEN.

EINLEITUNG

Die RF-Punch XLC Woofer sind eine komplette Produktlinie von Tief-Frequenzlautsprechern mit Durchmesser von 20 cm bis zu 46 cm, erhältlich in der Impedanz 4 - und 8 Ohm (Die RF Punch XLC Woofer wurden vorwiegend für den Einsatz in geschlossenen Gehäuse konstruiert). Durch die Verwendung neuester Materialien und Produktionstechniken können wir Ihnen heute einen Lautsprecher vorstellen, der hohe Lautstärken und tiefe Frequenzen selbst in sehr kleinen Volumen reproduzieren kann.

ANSCHLUßTERMINALS

Die Anschlußterminals wurden auf jeder Seite des Lautsprecherkorbes positioniert um eventuelle Kurzschlüsse auch bei hoher Leistung auszuschließen (Das Positiv-Terminal ist durch eine Farbmarkierung gekennzeichnet). Eine rote Farbmarkierung befindet sich immer bei einem Lautsprecher mit einer Impedanz von 8 Ohm, eine violette Farbmarkierung zeichnet die Lautsprecher mit der Impedanz 4 Ohm.

VOLUMEN-BERECHNUNG

Zur Volumen-Berechnung benötigen sie die genauen Maße und Dimensionen in Zentimetern.

Gehäuse- Volumen = (Kubik Liter)	Höhe (cm) x Breite (cm) x Tiefe (cm)
	1000

Sollten zwei gegenüberliegende Seiten ungleich lang sein, so können sie die Maße zusammen rechnen und durch zwei dividieren um den Durchschnitt zu erhalten. Dies macht Ihnen die Berechnung leichter und Sie müssen das Gehäuse nicht in Sektionen berechnen, die Sie danach wieder mühselig zusammen zählen müssen. Die Materialstärke beeinflusst natürlich auch das Innen-Volumen, so muss für eine präzise Berechnung die Materialstärke von Außen-Volumen abgezogen werden. Der Lautsprecher verringert ebenfalls das Innen-Volumen, auch er sollte natürlich heraus gerechnet werden. Jedes Lautsprecher-Volumen ist unter "Specifications" genau aufgelistet.

DER GEHÄUSE BAU

Um das Gehäuse so präzise wie möglich zu bauen, sollten die Gehäusewände sehr steif und luftundurchlässig sein, um dem entstehenden Luftdruck des Lautsprechers standhalten zu können. Wir empfehlen 1,9 cm mittelverdichtete Faserplatte (MDF), die in den meisten Baumärkten angeboten wird. Bei einem größeren Gehäuse sollten Sie Versteifungen durch Holzbalken montieren. Diese sollten – wie auch das gesamte Gehäuse – mit Holzleim geklebt und verschraubt oder vernagelt sein. Um eine höhere Dichte zu erreichen, empfiehlt es sich, die Kanten und Verschraubungen mit Silikon abzudichten und das Gehäuse von innen mit einer Hohlraumversiegelung zu behandeln.

LEGGERE CON ATTENZIONE LE SEGUENTI ISTRUZIONI PRIMA DELL'INSTALLAZIONE DEL PRODOTTO.

INTRODUZIONE

I woofer RF Punch XLC sono una linea completa di altoparlanti per basse frequenze con diametri che vanno da 20 a 46 cm e disponibili sia a 4 che a 8 ohm. (I woofer RF Punch XLC sono progettati per il funzionamento principale in cassa chiusa.). Impiegando le piú aggiornate tecnologie e materiali, siamo in grado di offrire altoparlanti che possono riprodurre un'elevata pressione sonora alle basse frequenze mantenendo i volumi di impiego assolutamente ridotti.

CONNESSIONI DI INGRESSO

I connettori di ingresso positivi e negativi sono montati sul cestello in posizioni speculari. Il montaggio separato impedisce al segnale musicale di cortocircuitarsi ad altissimi livelli di volume. (Il terminale di ingresso é indicato da una marcatura colorata sul cestello.) Un contrassegno rosso indica che l'impedenza dell'altoparlante é 8 ohm, il contrassegno viola é impiegato per i 4 ohm.

CALCOLO DEL VOLUME

Calcolare il volume é essenzialmente solo un problema di misurazione delle dimensioni in centimetri della cassa e di applicazione della formula:

Volume della cassa = (litri)	Alteza x Larghezza x Profonditá
	<hr/>
	1000

Se due pareti parallele sono di dimensioni diverse (prisma), semplicemente sommatele e dividete il risultato per due. Impiegando il risultato ottenuto potete calcolare il volume senza dividere la cassa i sezioni. Lo spessore del legno riduce il volume interno, per cui é necessario sottrarlo dalle dimensioni esterne. Anche il volume dell'altoparlante stesso riduce il volume della cassa e deve essere sottratto. Il volume che ciascun altoparlante contribuisce a togliere dalla cassa é indicato nelle tabelle con le specifiche.

COSTRUIRE UNA CASSA

Per ottenere le prestazioni massime, le pareti della cassa devono essere rigide e non flettere sotto la sollecitazione della elevata pressione generata dal woofer. Noi raccomandiamo l'impiego di MDF con uno spessore minimo di 19 mm, materiale facilmente reperibile in tutte le falegnamerie. Per casse di dimensioni molto grandi é indispensabile prevedere dei rinforzi interni. Le giunture devono essere incollate e fissate con viti o chiodi in abbondanza. Interamente le giunture devono essere siliconate per impedire trafilati d'aria. Anche la colla da legno funziona bene. Essendo il MDF un materiale poroso si consiglia di sigillare l'esterno con materiali poliuretanici.

NOTES

NOTES

MADE IN THE USA

This product is designed, developed and assembled in the USA by a dedicated group of American workers. The majority of the components used in the construction of this product are produced by American companies. However, due to the global nature of their manufacturing facilities and the loudspeaker parts industry in general, some parts may be manufactured in other countries.

Rockford Fosgate

Rockford Corporation
546 South Rockford Drive
Tempe, Arizona 85281 U.S.A.
In U.S.A., (602) 967-3565
In Europe, Fax (49) 8503-934014
In Japan, Fax (81) 559-79-1265
www.rockfordfosgate.com