

RFT-1081
RFT-1101

"The Box
That Rocks"



Installation Reference Sheet
Páginas de Referencia para la Instalación
Schéma d'Installation
Installations Beiblatt
Istruzioni di Installation



RFT-1081 RFT-1101	8" Box That Rocks 10" Box That Rocks	Specification Reference Sheet
----------------------	---	-------------------------------------

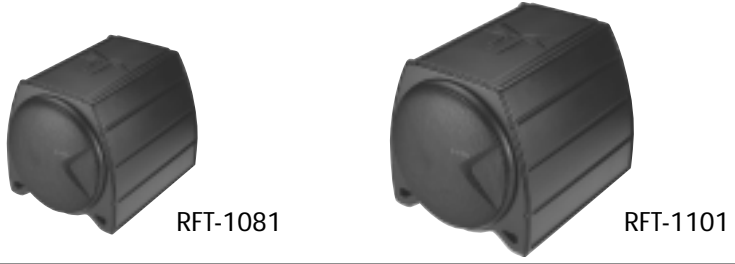

FEATURES

ENCLOSURE

- **Roto-Mold Construction** – The use of Roto-Mold manufacturing produces a composite enclosure with seamless construction. This greatly increases rigidity to prevent the enclosure from flexing and allows custom designs to be fabricated. The result is a radical, stronger, more reliable enclosure.
- **Acoustic Suspension Enclosure**– The Subz enclosure uses an acoustic suspension design (sealed) for optimum performance. The enclosure is matched to the woofer for deep bass output while requiring minimal operating space.
- **Anti-Tip Design** – The enclosure has a flat bottom to provide a solid foundation for securing it to the vehicle and prevent it from rolling.

PUNCH WOOFER

- **PVA Cone** – The cone material used is a spruce pulp paper and provides the necessary combination of weight and strength to allow high levels of output without cone break up. The cone is also treated with a water resistant PolyVinyl Acetate (PVA) emulsion which increases cone rigidity and lowers distortion.
- **Aluminum Voice Coil Former** – The voice coil is made of multiple layers of copper wound on a black, anodized, aluminum former. This improves the speaker's power handling by efficiently dissipating heat from the voice coil.
- **Hyper-Extended Pole Piece** – The pole piece has been extended to provide a more linear magnetic field for the operation of the woofer. This lowers distortion and provides the woofer with better low frequency response.
- **Vented Bumped Back Plate** – The back plate has been stepped deeper to allow the woofer more excursion for harder hitting bass. Additionally, the back plate is vented with a radiused aerodynamic vent that efficiently and quietly keeps the voice coil cool.

SPECIFICATIONS

RFT-1081 Frequency Response 30Hz-400Hz Enclosure Vb (ft ³ / liter) 0.35 (9.91L) Baffle Thickness 0.300" Speaker Model RFP-1408 Nominal Impedance 4Ω Fs 30Hz RE 3.6Ω LE 2.5mH QMS 4.89 QES 0.32 QTS 0.30 VAS (ft ³ / liter) 0.883/25L XMAX (in/mm) 0.32"/8mm SPL (dB @ 1w/1m) 85dB Power Handling (RMS/Peak) 200W/400W Speaker Displacement (ft ³ / liter) 0.05/1.416L Overall Dimensions 9 ⁷ / ₁₆ "H x 10 ³ / ₁₆ "W x 12 ⁷ / ₁₆ "L (24.29cm x 25.87cm x 31.59cm) Weight 13.5 lbs. (6.12kg)	RFT-1101 Frequency Response 24Hz-400Hz Enclosure Vb (ft ³ / liter) 0.81 (22.94L) Baffle Thickness 0.300" Speaker Model RFP-1410 Nominal Impedance 4Ω Fs 24Hz RE 3.6Ω LE 2.5mH QMS 4.08 QES 0.27 QTS 0.25 VAS (ft ³ / liter) 2.72/77L XMAX (in/mm) 0.32"/8mm SPL (dB @ 1w/1m) 87dB Power Handling (RMS/Peak) 200W/400W Speaker Displacement (ft ³ / liter) 0.06/1.699L Overall Dimensions 11 ⁷ / ₈ "H x 12 ⁵ / ₈ "W x 15 ⁵ / ₈ "L (30.16cm x 32.07cm x 39.69cm) Weight 17.8 lbs. (8.07kg)
---	---

ACCESSORY PACK

- (2) Nylon Straps (4) Plastic Mounting Brackets (8) Mounting Screws



Specifications subject to change without notice

WARNING: PLEASE FOLLOW THESE INSTRUCTIONS CAREFULLY. FAILURE TO FOLLOW THESE INSTRUCTIONS OR TO INSTALL THE ENCLOSURE PROPERLY COULD RESULT IN DETACHMENT OF THE ENCLOSURE AND SERIOUS INJURY.

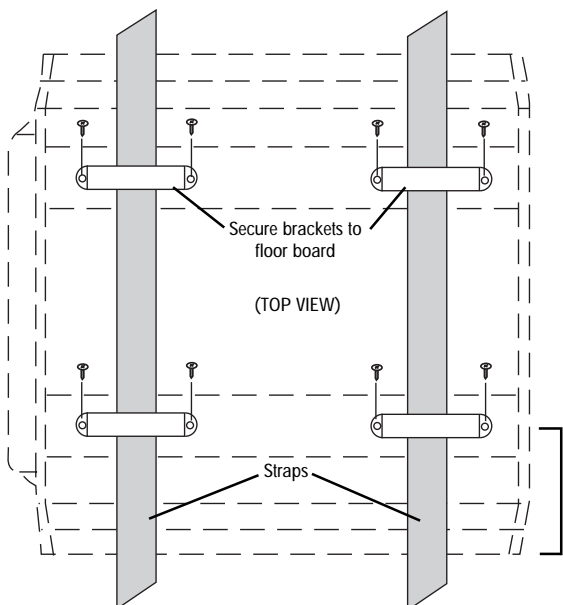

1. INSTALL THE MOUNTING BRACKETS

Place the enclosure in the desired mounting location and position the mounting brackets approximately 4" from each end. Push the mounting brackets as close as possible to the enclosure without moving or lifting it. Carefully remove the enclosure and secure the brackets using the supplied screws.

NOTE: Be careful not to mount the enclosure on cardboard or plastic panels. Doing so may allow the screws to pull out from the panel due to road vibration or sudden vehicle stops.

CAUTION: Before drilling, check under vehicle to avoid damage to brake or fuel lines, etc.

2. INSTALL THE MOUNTING STRAPS

Feed each strap through the pair of mounting brackets and position the enclosure in place over the straps. Tighten each strap securely.

NOTE: Be sure the mounting straps are looped through the buckle correctly. Check the straps regularly to ensure your enclosure is securely mounted in place.

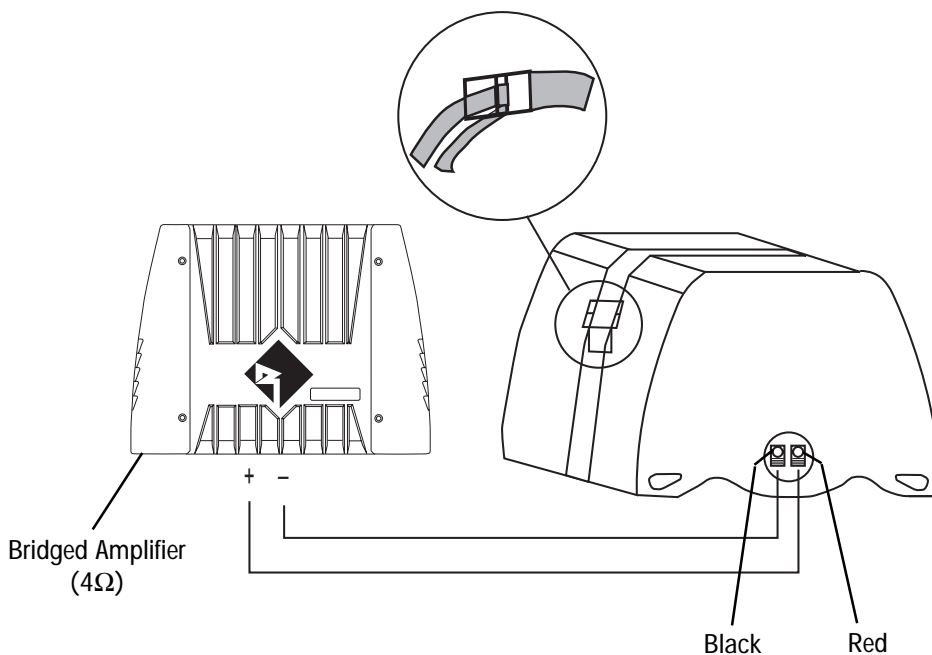

3. RUN THE SPEAKER CABLE FROM THE AMP

When routing the speaker cable from the amplifier, avoid running it close to any sources of high current (e.g., wiring harnesses). The positive (+) speaker output from the amp connects to the red terminal of the enclosure, and the negative (-) connects to the black terminal.

RFT-1081
RFT-1101

8" Box That Rocks
10" Box That Rocks

Páginas de Referencia
para la Instalación

LEA DETENIDAMENTE LAS SIGUIENTES INSTRUCCIONES DE INSTALACIÓN DEL PRODUCTOR. EVITARA POSIBLES DAÑOS A VD., AL VEHÍCULO O AL PRODUCTO.

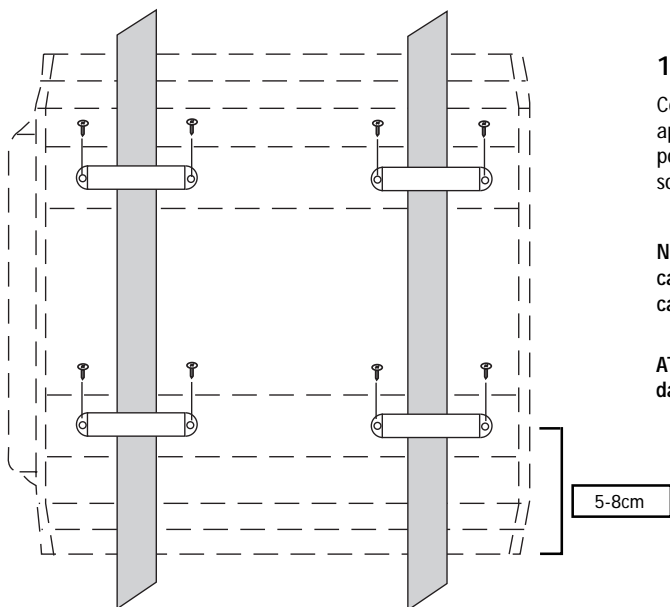

1. INSTALACIÓN DE LOS SOPORTES DE ANCLAJE

Coloque el recinto en la posición deseada y posicione los soportes de anclaje aproximadamente a 10cm hacia el interior de los finales del recinto. Júntelos lo mas posible ei recinto sin mover el mismo. Cuidadosamente quite el recinto y fije los soportes usando los tornillos que se le han suministrado.

NOTA: Preste atención donde atornilla los soportes. Evite paneles de plástico y cartón piedra. Sik lo hiciera los tornillos podrian arrancarse por la vibración de la carretera o durante una frenada brusca.

ATENCIÓN: Antes de taladrar revise debajo del vehiculo para prevenir daños en las conducciones de frenos o carburante.

2. INSTALACIÓN DE LAS BRIDAS DE MONTAJE

Asegure los angulos de montaje y posicione el tubo en el lugar deseado (sobre los angulos) estire las bridas y asegurelas.

NOTA: Asegurese de que las bridas pasan por el bucle correctamente. Verifique regularmente que el tubo este fijamente asegurado.

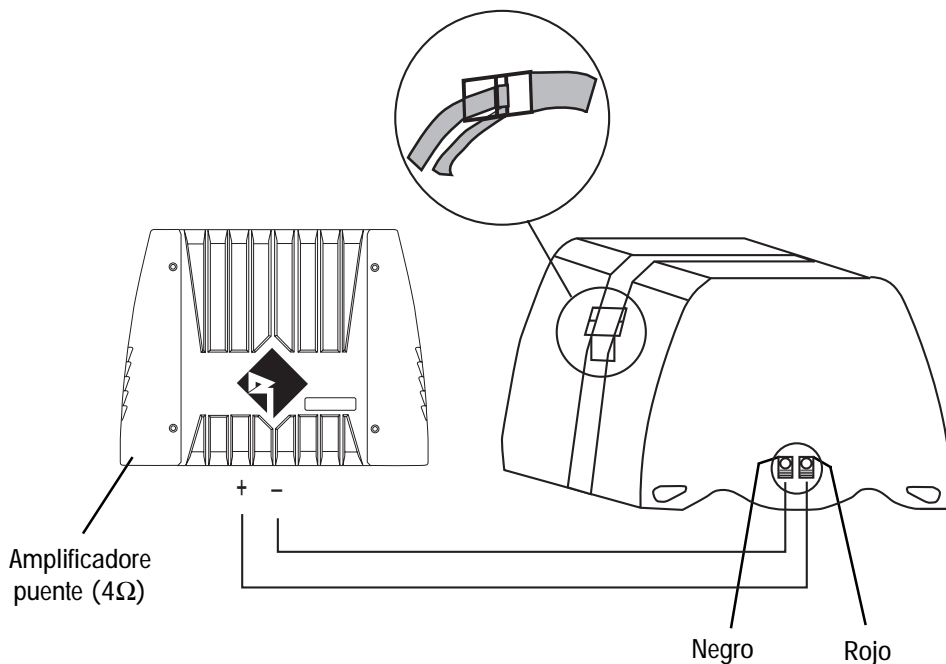

3. RECORRIDO DEL CABLE DE ALTAVOZ DESDE EL AMPLIFICADOR

Al llevar el cable de altavoz desde el amplificador, evite que pase cerca de cualquier fuente de alto corriente (cables de alimentacion). El terminal positive (+) de las salida de rojo del tubo, y el terminal negativo (-) al terminal negro.

RFT-1081
RFT-11018" Box That Rocks
10" Box That RocksSchéma
d'Installation

ATTENTION: Veuillez suivre ces instructions. Ne pas les suivre ou ne pas installer correctement le caisson pourrait causer des dégâts ou de sérieuses blessures, en cas d'accident.

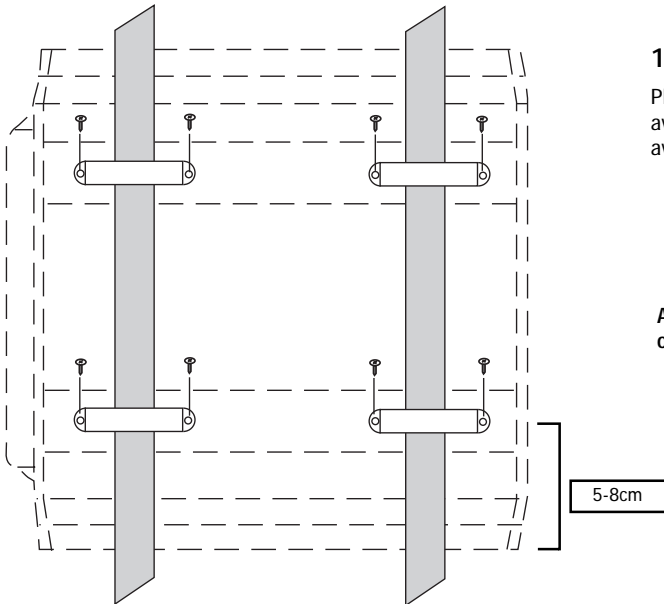

1. INSTALLATION DES LANIÈRES DE MONTAGE

Placez le caissons dans l'emplacement désiré et mettez-les crochets à environ 10cm avant chaque extrémité de celui-ci. Retirez doucement le caisson et fixer les crochets avec les vis fournies aussi près que possible du caisson sans le bouger ou le soulever.

ATTENTION: Avant de percer, assurez-vous de ne pas endommager les organes vitaux du véhicule (conduit de freinage, d'essence, etc.)

2. INSTALLATION DES LANIÈRES DE MONTAGE

Passez chaque lanière dans la paire de crochets de montage et positionner le caisson a sa place. Serrez bien chaque lanière.

ATTENTION: Veuillez à ce que chaque lanière de montage soit correctement passée dans la boucle. Contrôlez régulièrement les boucles afin que le caisson reste solidement mis en place.

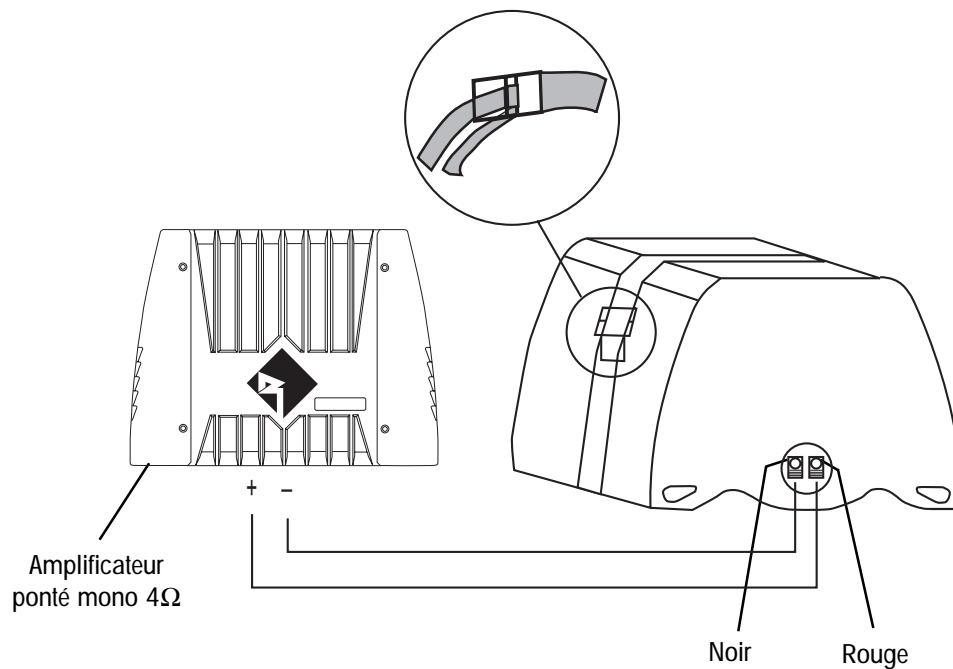

3. BRANCHEMENT DU CÂBLE HAUT-PARLEUR DE L'AMPLIFICATEUR

En plaçant le câble haut-parleur provenant de l'amplificateur, éviter son cheminement à proximité d'une source de courant importante. La sortie positive de l'amplificateur se connecte sur le bornier rouge du caisson, le négatif se branche sur le bornier noir.

RFT-1081
RFT-1101

8" Box That Rocks
10" Box That Rocks

Installations
Beiblatt

WARNUNG: Bitte lesen Sie diese Gebrauchsanweisung zuerst sorgfältig durch. Dies verhindert den falschen Einbau des Gehäuses und damit evtl. Garantiefälle.

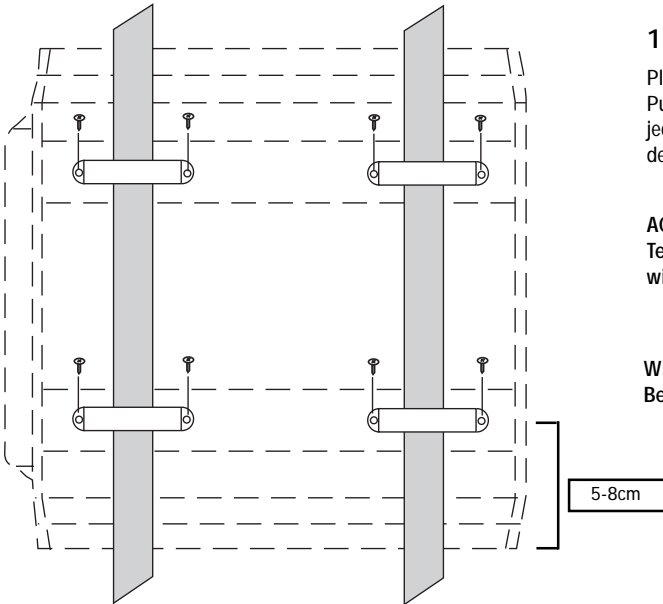

1. EINBAU DER BEFESTIGUNGSPUNKTE

Plazieren Sie das Gehäuse an dem ausgesuchten Platz. Kennzeichnen Sie nun die Punkte, an denen die Befestigungsösen festgeschraubt werden sollen. Ca 10 cm von jedem Ende des Gehäuses zur Gehäusemitte hin. Schrauben Sie dann vorsichtig mit den dafür vorgesehenen Schrauben die Ösen am Gehäuse fest

ACHTUNG: Befestigen Sie das Gehäuse nicht an Plastik oder leicht zerbrechlichen Teilen, die beim Festzurren beschädigt werden könnten. Das Gehäuse muß so fest wie möglich gezogen werden, um Vibrationen zu vermeiden.

WICHTIG: Achten Sie vor dem Bohren darauf, daß Fahrzeuggegenstände wie Benzinleitungen, Tank oder ähnliches beschädigt werden können.

2. EINBAU DER BEFESTIGUNGSBÄNDER

Ziehen Sie die Bänder durch die Befestigungsösen und plazieren Sie das Gehäuse an dem dafür vorgesehenen Ort. Ziehen Sie nun die Bänder fest.

ACHTUNG: Achten Sie darauf, daß die Bänder richtig durch die Ösen geführt wurden. Kontrollieren Sie die Bänder, ob das Gehäuse richtig fest und am richtigen Ort sitzt.

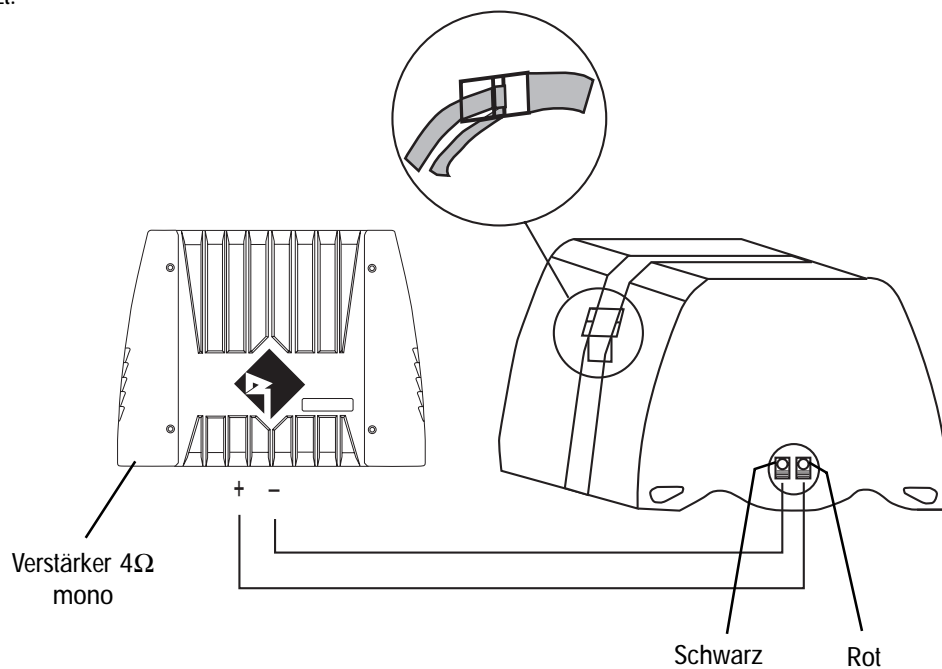

3. ANSCHLUß DES LAUTSPRECHERKABELS

Beim Anschluß des Lautsprecherkabels sollten Sie darauf achten, daß das Kabel keine stromführenden Kabel kreuzt, um Einstreuungen zu verhindern. Die Plus-Leitung des Lautsprecherkabels kommt in die rote Klemme des Terminals, die Negativ-Leitung in die schwarze Klemme des Terminals.

**RFT-1081
RFT-1101**

**8" Box That Rocks
10" Box That Rocks**

**Istruzioni di
Installazione**

ATTENZIONE: Si prega di seguire attentamente queste istruzioni. Non farlo o non fissare in modo corretto il diffusore potrebbe risultare dannoso per le persone e per l'apparecchio.

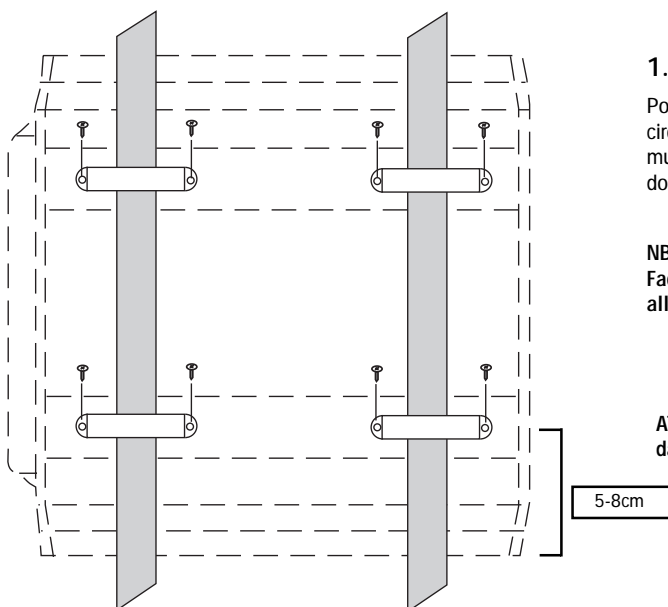

1. MONTARE I FISSANTI

Posizionare il diffusore nella zona desiderata e posizionare le staffe di fissaggio a circa 10 cm dalle estremità. Spingere le staffe il più vicino possibile al diffusore senza muoverlo o sollevarlo. Togliere con cura il diffusore e fissare le staffe con le viti a dotazione.

NB: Attenzione a non fissare il diffusore su pannelli in cartone o plastic. Facendolo le viti potrebbero essere spinte fuori dal pannello a causa di vibrazioni alla guida o improvvise frenate.

ATTENZIONE: Prima di trapanare controllare sotto il veicolo per evitare di danneggiare l'impianto di frenata, i condotti di carburante, ecc.

5-8cm

2. MONTARE LE CINGHIE

Far passare le due cinghie attraverso le staffe di fissaggio e riposizionare il diffusore nella posizione prescelta tra le staffe (sopra le cinghie). Stringere bene le cinghie.

NB: Assicurarsi che le cinghie siano correttamente passate nelle fibbie. Controllare le cinghie periodicamente per assicurarsi che il diffusore sia saldamente fissato al suo posto.

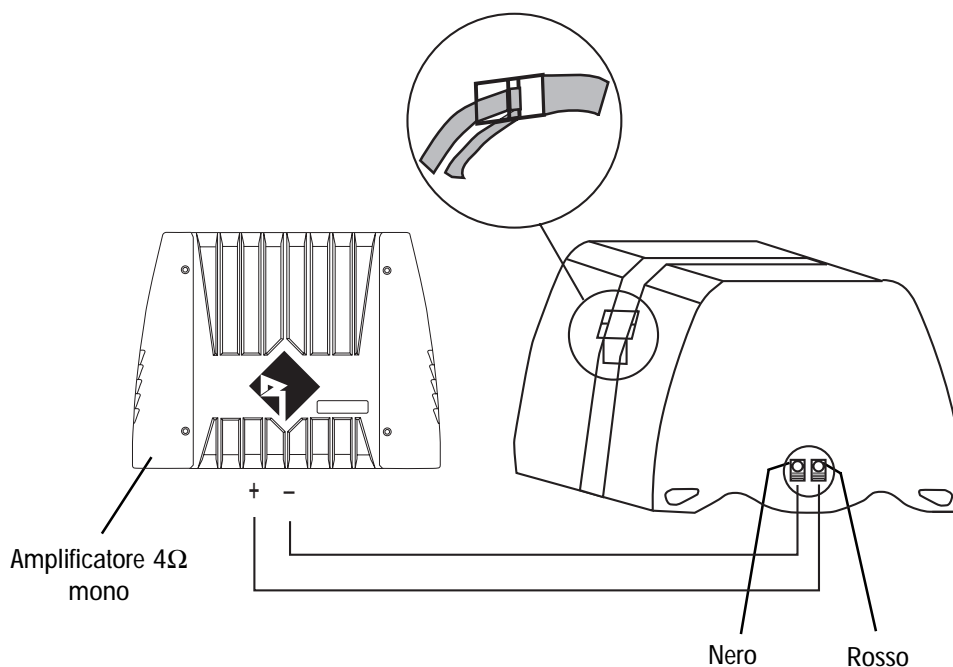

3. FAR CORRERE IL CAVO DELL'ALTOPARLANTE ALL'AMPLIFICATORE

Quando fate correre il cavo dell'altoparlante all'amplificatore non fatelo passare vicino a qualsiasi cavo dell'impianto elettrico di serie dell'auto. Il segnale positivo dell'altoparlante (+) in uscita dall'amplificatore è collegato al terminal rosso del diffusore, e il negativo (-) al terminale nero.

LIMITED WARRANTY INFORMATION

Rockford Corporation offers a limited warranty on Rockford Fosgate products on the following terms:

- **Length of Warranty**

3 years on electronics
2 years on source units

90 days on electronic B-stock (receipt required)
30 days on speaker B-stock (receipt required)

- **What is Covered**

This warranty applies only to Rockford Fosgate products sold to consumers by Authorized Rockford Fosgate Dealers in the United States of America or its possessions. Product purchased by consumers from an Authorized Rockford Fosgate Dealer in another country are covered only by that country's Distributor and not by Rockford Corporation.

- **Who is Covered**

This warranty covers only the original purchaser of Rockford product purchased from an Authorized Rockford Fosgate Dealer in the United States. In order to receive service, the purchaser must provide Rockford with a copy of the receipt stating the customer name, dealer name, product purchased and date of purchase.

- **Products found to be defective** during the warranty period will be repaired or replaced (with a product deemed to be equivalent) at Rockford's discretion.

- **What is Not Covered**

1. Damage caused by accident, abuse, improper operations, water, theft
2. Any cost or expense related to the removal or reinstallation of product
3. Service performed by anyone other than Rockford or an Authorized Rockford Fosgate Service Center
4. Any product which has had the serial number defaced, altered, or removed
5. Subsequent damage to other components.
6. Any product purchased outside the U.S.
7. Any product not purchased from an Authorized Rockford Fosgate Dealer

- **Limit on Implied Warranties**

Any implied warranties including warranties of fitness for use and merchantability are limited in duration to the period of the express warranty set forth above. Some states do not allow limitations on the length of an implied warranty, so this limitation may not apply. No person is authorized to assume for Rockford Fosgate any other liability in connection with the sale of the product.

- **How to Obtain Service**

Please call 1-800-669-9899 for Rockford Customer Service. You must obtain an RA# (Return Authorization number) to return any product to Rockford Fosgate. You are responsible for shipment of product to Rockford.

Ship to: **Electronics**
Rockford Corporation
Warranty Repair Department
2055 E. 5th Street
Tempe, AZ 85281
RA#: _____

Ship to: **Speakers**
Rockford Acoustic Design
(Receiving-speakers)
609 Myrtle N.W.
Grand Rapids, MI 49504
RA#: _____

MADE IN THE USA

This product is designed, developed and assembled in the USA by a dedicated group of American workers. The majority of the components used in the construction of this product are produced by American companies. However, due to the global nature of their manufacturing facilities and the electronics parts industry in general, some parts may be manufactured in other countries.

Rockford Fosgate
Rockford Corporation
546 South Rockford Drive
Tempe, Arizona 85281 U.S.A.
In U.S.A., (602) 967-3565
In Europe, Fax (49) 850-3934-014
In Japan, Fax (81) 559-79-1265