

RFR-1414

RFR-1514

RFR-1614

power

 **Rockford Fosgate**
car audio for  **fanatics**

power systems
operation & installation

 **the punch**[®]



Dear Customer,

Congratulations on your purchase of the world's finest brand of car audio speakers. At Rockford Fosgate we are fanatics about musical reproduction at its best, and we are pleased you chose our product. Through years of engineering expertise, hand craftsmanship and critical testing procedures, we have created a wide range of products that reproduce music with all the clarity and richness you deserve.

For maximum performance we recommend you have your new Rockford Fosgate product installed by an Authorized Rockford Fosgate Dealer, as we provide specialized training through Rockford Technical Training Institute (RTTI). Please read your warranty and retain your receipt and original carton for possible future use.

Great product and competent installations are only a piece of the puzzle when it comes to your system. Make sure that your installer is using 100% authentic installation accessories from Connecting Punch in your installation. Connecting Punch has everything from RCA cables and speaker wire to Power line and battery connectors. Insist on it! After all, your new system deserves nothing but the best.

To add the finishing touch to your new Rockford Fosgate image order your Rockford wearables, which include everything from T-shirts and jackets to hats and sunglasses.

To get a free brochure on Rockford Fosgate products and Rockford accessories, in the U.S. call 602-967-3565 or FAX 602-967-8132. For all other countries, call +001-602-967-3565 or FAX +001-602-967-8132.

PRACTICE SAFE SOUND™

CONTINUOUS EXPOSURE TO SOUND PRESSURE LEVELS OVER 100dB MAY CAUSE PERMANENT HEARING LOSS. HIGH POWERED AUTOSOUND SYSTEMS MAY PRODUCE SOUND PRESSURE LEVELS WELL OVER 130dB. USE COMMON SENSE AND PRACTICE SAFE SOUND.

If, after reading your manual, you still have questions regarding this product, we recommend that you see your Rockford Fosgate dealer. If you need further assistance, you can call us direct at 1-800-795-2385. Be sure to have your serial number, model number and date of purchase available when you call.

The serial number can be found on the outside of the box. Please record it in the space provided below as your permanent record. This will serve as verification of your factory warranty and may become useful in recovering your product if it is ever stolen.

Serial Number: _____

Model Number: _____

TABLE OF CONTENTS

Introduction	1
Package Contents	1
Technical Design Features	2
Design Features	6
Installation Considerations	7
Mounting Location	8
Installation	9
Troubleshooting	14
Specifications	16
Warranty Information	17
International Information	18

GETTING STARTED

Welcome to Rockford Fosgate! This manual is designed to provide information for the owner, salesperson and installer. For those of you who want quick information on how to install this product, please turn to the **Installation Section** of this manual or refer to the icons listed below. Other information can be located by using the Table of Contents. We, at Rockford Fosgate, have worked very hard to make sure all the information in this manual is current. But, as we are constantly finding new ways to improve our product, this information is subject to change without notice.



Sections marked **INSTALLATION** include "slam dunk" wiring connections

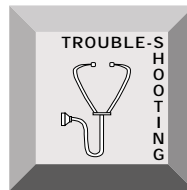

Sections marked **TROUBLESHOOTING** include recommendations for curing installation problems

INTRODUCTION

This manual provides information on the features and installation of the Punch Power Systems. We suggest you save this manual for future reference.

We strongly recommend you have your Authorized Rockford Fosgate Dealer install the Punch Power System. If you do choose to install the system yourself, please be sure to read the entire manual before beginning.

PACKAGE CONTENTS

RFR-1414

- (1) Installation & Operation Manual
- (2) 4" Midrange Speakers
- (2) 4" Speaker Grilles
- (2) Speaker Grille Rings
- (2) Speaker Grille Gaskets
- (2) RFR-142x Crossovers
- (2) 25mm Tweeters
- (2) Surface Mount Cups
- (2) Surface Mount Baseplates
- (2) Flush Mount Cups
- (2) Flush Mount Baseplates
- (2) Mounting Brackets
- (2) 30' 16 gauge speaker wire
- (8) #8 x 1.24 Phillips Mounting Screws
- (4) 8-32 x .50 Hex Head Bolts
- (4) 8-32 Nuts

RFR-1514

- (1) Installation & Operation Manual
- (2) 5.25" Midrange Speakers
- (2) 5.25" Speaker Grilles
- (2) Speaker Grille Rings
- (2) Speaker Grille Gaskets
- (2) RFR-142x Crossovers
- (2) 25mm Tweeters
- (2) Surface Mount Cups
- (2) Surface Mount Baseplates
- (2) Flush Mount Cups
- (2) Flush Mount Baseplates
- (2) Mounting Brackets
- (2) 30' 16 gauge speaker wire
- (8) #8 x 1.24 Phillips Mounting Screws
- (4) 8-32 x .50 Hex Head Bolts
- (4) 8-32 Nuts

RFR-1614

- (1) Installation & Operation Manual
- (2) 6.5" Midrange Speakers
- (2) 6.5" Speaker Grilles
- (2) Speaker Grille Rings
- (2) Speaker Grille Gaskets
- (2) RFR-142x Crossovers
- (2) 25mm Tweeters
- (2) Surface Mount Cups
- (2) Surface Mount Baseplates
- (2) Flush Mount Cups
- (2) Flush Mount Baseplates
- (2) Mounting Brackets
- (2) 30' 16 gauge speaker wire
- (8) #8 x 1.24 Phillips Mounting Screws
- (4) 8-32 x .50 Hex Head Bolts
- (4) 8-32 Nuts

TECHNICAL DESIGN FEATURES

◆ Titanium Dome

The titanium dome used in the Power tweeter allows the voice coil assembly to efficiently dissipate heat. This feature allows the tweeter to be driven at higher operating levels without sacrificing sound quality.

THE RESULT: High power handling with excellent response.

◆ Neodymium Magnets

The high ionic compound of neodymium enables a smaller tweeter magnet assembly to be used as opposed to the much larger ferrite magnets that are commonly used in speaker manufacturing.

THE RESULT: An efficient magnet which allows smaller tweeter construction.

◆ Magnetic Fluid Cooling

Magnetic fluid is a synthetic liquid consisting of microscopic magnetic particles. The fluid has four times the thermal conductivity as air which makes it an ideal cooling agent. Magnetic fluid is injected into the voice coil gap which helps dissipate heat generated by the voice coil.

THE RESULT: A thermal conductor which allows increased power handling.

◆ Swivel Mount Design

The tweeter is encapsulated in a variable swivel housing. This design allows direct dispersion of the tweeter in order to accommodate various mounting positions. The swivel mount design allows the tweeter to maximize its sonic potential.

THE RESULT: Precise tweeter imaging regardless of mounting position.

Midrange Features

◆ TPR Rubber Surround

TPR (Thermal Plastic Rubber) is resilient to temperature variations and provides a consistent support necessary for the linear motion of the speaker cone. In addition, the inherent damping capabilities eliminates the transmission of sonic disturbances between the cone and the frame of the speaker. This greatly improves the clarity of the speaker's midrange frequency response.

THE RESULT: Improves speaker's frequency response.

◆ Flat Spider

The speaker's linear compliance is balanced through the use of a "proprietary" flat spider design. A flat spider provides symmetrical control of the voice coil through its cone excursion. Linear cone excursion reduces harmonic distortion for improved sound quality.

THE RESULT: Reduces mechanical distortion for better sound quality

◆ High Temperature Voice Coil

The voice coil is of a high temperature copper wire construction. The wire is wound in two layers on a black, anodized, aluminum voice coil former. The voice coil former dissipates heat away from the voice coil improving the speaker's thermal stability and improving the reliability of the speaker.

THE RESULT: Improves reliability by dissipating generated heat.

◆ Vented Pole Piece

The vented pole piece by design, ensures proper ventilation to cool the voice coil and maintain lower operating temperatures. The vent on the rear of the magnet reduces back pressure and allows cool air to circulate in the voice coil gap. The air circulation increases the thermal power handling of the speaker.

THE RESULT: Improves power handling by cooling the voice coil.

◆ Silver Powder Coat Finish

Powder coating has long been the industry standard for durability in protective metal finishes. A dry powder (non-aerosol) is electrostatically applied to the metal and “baked” on to provide a hard “shell-like” finish. As an additional benefit, powder coating is the only finishing process that releases no toxic chemicals into our ozone.

THE RESULT: A durable and “earth friendly” metal finish.

Crossover Features

◆ Optical Compression Circuit

The supplied passive crossovers utilize an optical compression circuit for tweeter protection. This protection circuit absorbs the destructive signal caused when the amplifier's output is clipped. This greatly increases the power handling capability and the reliability of the tweeter.

THE RESULT: Increased tweeter reliability under harsh conditions.

◆ Series Notch Filter

The Series Notch Filter compensates for the inductive load presented by the driver (speaker). The filter's primary function is to dampen and eliminate the effect that driver resonance has on the crossover. The Series Notch Filter flattens out the inductive load which greatly improves driver performance by providing a “stable” crossover point.

THE RESULT: Improves driver performance by reducing resonant peak.

◆ Zobel Network

The Zobel network compensates for the impedance rise presented by the driver (speaker). The network flattens out the gradual impedance rise produced by the voice coil which typically results in high frequency rolloff. The Zobel Network compensates for this natural rolloff which allows the driver to produce a more linear response up to the tweeter crossover point.

THE RESULT: Compensates for natural high frequency rolloff of midrange.

◆ Adjustable Tweeter Level Matching

The crossover utilizes a series power resistor for tweeter level matching. The factory set tweeter output level is -0dB , however, can be reduced -3dB to create a smoother transition between the midrange and tweeter. The ability to level match allows the system to be custom "tuned" for a particular listener or setup.

THE RESULT: Allows custom setup of tweeter output level.

DESIGN FEATURES

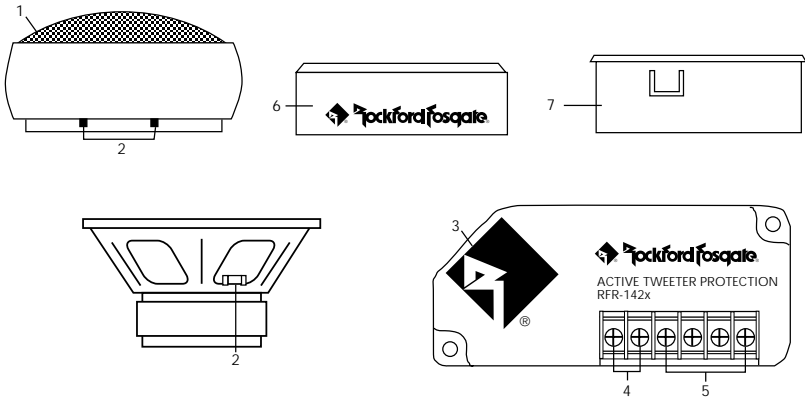

1. **Wire Mesh Grille** – The Wire Mesh Grille protects the tweeter diaphragm from foreign objects and curious fingers.
2. **Input Terminals** – The “+” Terminal indicates the positive/plus terminal of the speaker. The “-” Terminal indicates the negative/minus terminal of the speaker. These terminals connect to the corresponding output of the supplied crossover.
3. **Variable Mount Logo** – The Diamond “R” logo can be orientated in its housing to accommodate vertical or horizontal crossover mounting.
4. **Input Screw Terminals** – The Input Screw Terminals connect to the outputs of the amplifier. These terminals accept bare wire or 1/4" spade lugs and are gold-plated to resist corrosion.
5. **Output Screw Terminals** – The Output Screw Terminals connect to the input of the tweeter and midrange. These terminals accept bare wire or 1/4" spade lugs and are gold-plated to resist corrosion.
6. **Surface Mount Cup** – This cup is used to “surface mount” the tweeter on a panel.
7. **Flush Mount Cup** – This cup is used to recess or “flush mount” the tweeter into a panel.

INSTALLATION CONSIDERATIONS

Tools Needed

The following is a list of some of the tools necessary for the installation of your speakers.

Power Drill with assorted bits #2 Phillips Screwdriver
Tape Measure Hole Saw (2")
Voltmeter

General

1. For safety, disconnect the negative lead from the battery prior to beginning the installation.
2. Never run wires underneath the vehicle. Running the wires inside the vehicle provides the best protection.
3. Avoid running wires over or through sharp edges. Use rubber of plastic grommets to protect any wires routed through metal.
4. Mount the speakers/crossovers away from electrical sources (other than the amplifier) i.e., power cables, electronic fuel pumps, vehicle computers, and other potential noise sources.
5. Mount the speakers/crossovers away from areas of extreme heat or moisture.

Speakers

1. Make sure there is an area large enough of the speaker to mount.
Warning! Failure to do this can cause damage to the speaker if the speaker frame is bent during installation.
 2. Check to see that the location is deep enough for the speaker(s) and the location does not interfere with the normal operation of the vehicle.
 3. When mounting the speaker(s) in the door of a vehicle, make sure the speaker(s) do not interfere with either the door or window operation.
 4. When mounting the speaker(s) on the rear deck of the vehicle, check the operation of the rear hatch or trunk lid. Make sure the torsion bars and other moving parts are not obstructed by the speaker(s) installation.
- Please refer to the **Specifications section** of this manual for proper mounting diameter and depth of the speaker(s).

Crossovers

1. Make sure there is a flat area large enough for the crossover to mount.
2. For best results, mount the crossover(s) next to the amplifier for a decorative finish to the installation and provide an easy upgrade (no new wires to run) for a bi-amp Rockford Fosgate system in the future.

MOUNTING LOCATION

A solid front stage with a good image is one of the most difficult tasks to achieve in a vehicle. No car has the optimum listening environment. This makes proper sound staging very difficult to accomplish. Most speakers tend to be placed where they will fit easily, as opposed to where they can perform the best. *The mounting location of your speakers will have a great effect on the sound quality of your stereo system. The special care taken to place the speakers will yield many hours of listening enjoyment in return. Several important recommendations should be followed.*

- Place the speakers where they have a direct path to the listening area.
- For the best integration between the midrange and tweeter, the tweeter should be placed less than 2" from the midrange. (Figure 1)
- If you cannot place the tweeter less than 2" from the midrange, then place the tweeter more than 7" from the midrange. Placing the tweeter 2"-7" from the midrange can cause destructive interference (frequency response problems) which will affect the speaker's ability to reproduce the frequency range around the crossover frequency of the system.
- Whenever possible, place the tweeter directly above or below the midrange as this maximizes the imaging (point source) capability of the speakers. (Figure 2)

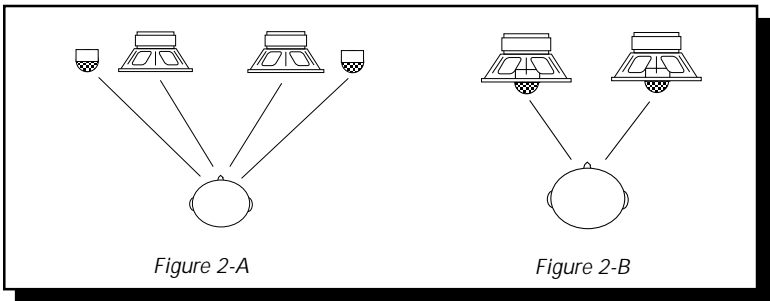
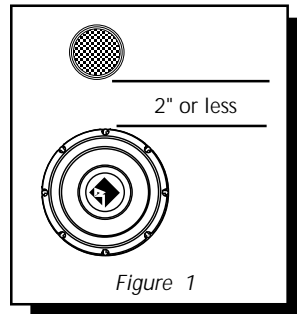

- Sound radiated from a “point source” has the most optimum stereo imaging because the separation of the acoustical centers between the midrange and tweeter for each channel is at the optimum. Figure 2-A describes a horizontal speaker alignment. In a closed environment such as an automobile, horizontal speaker alignment can cause severe amplitude and phase differences which will degrade not only the imaging, but also the frequency response. This is due to the path length differences between the midrange and tweeter. Figure 2-B displays a vertical alignment between the midrange and tweeter. With a vertical alignment, the path length difference between the midrange and tweeter are reduced to a minimum. The result is a negligible difference in path lengths between the midrange and tweeter regardless of the proximity of the listener to the speakers. Mounting the speaker with minimum path length difference will ensure the best staging and imaging possible from your audio system.

INSTALLATION



Mounting the Midrange

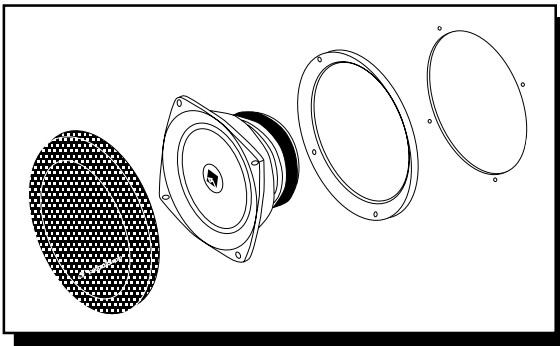

1. Cut the proper size hole for the midrange/woofer.
 - For the RFR-1404, cut a $3\frac{13}{16}$ " (96.8mm) diameter hole
 - For the RFR-1405, cut a $4\frac{7}{8}$ " (123.8mm) diameter hole
 - For the RFR-1406, cut a $5\frac{5}{8}$ " (142.9mm) diameter hole
2. Place the mounting ring over the mounting hole and mark the location of the screw mounting holes.
3. Remove the ring. Drill the holes for the screws using a 1/8" drill bit.
4. Route the wire through the hole.
5. Place the mounting ring over the hole.
6. Attach the wires and be sure to observe the proper speaker polarity.
7. Place the speaker into the hole and screw the speaker into place.

Be careful not to bend the speaker frame during this step.
8. Press the speaker grille into the mounting ring.

Surface Mount Tweeter (Method #1)

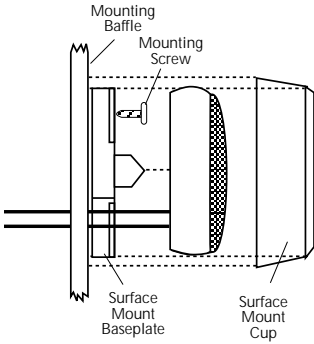

Exploded View

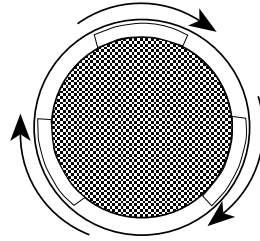

Front View
(twist clockwise to lock)

- Use when mounting tweeter to a solid surface (metal, wood, etc.)

Surface Mount Tweeter (Method #2)

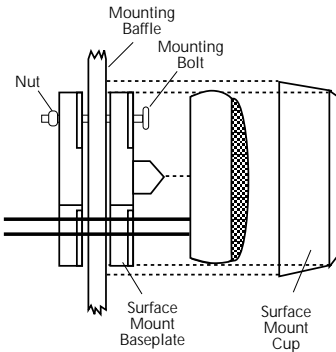

Exploded View

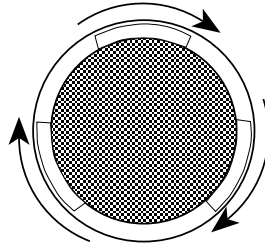

Front View
(twist clockwise to lock)

- Use when mounting tweeter to a surface needing reinforcement

Flush Mount Tweeter

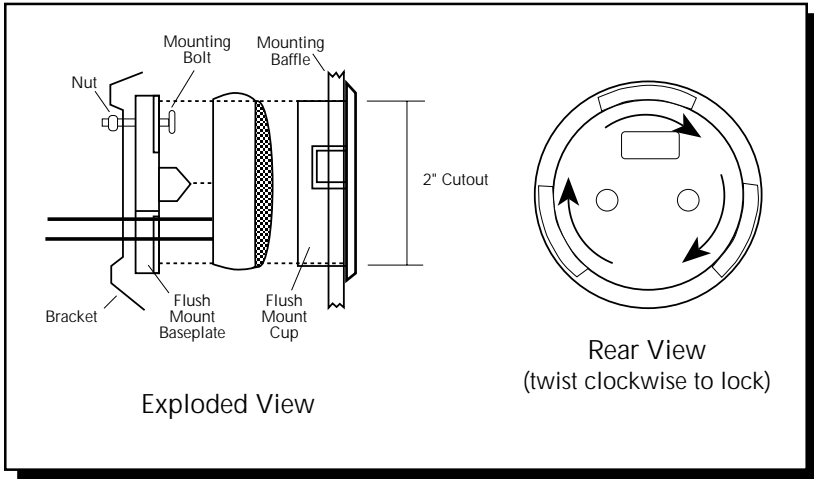

Crossover Connections

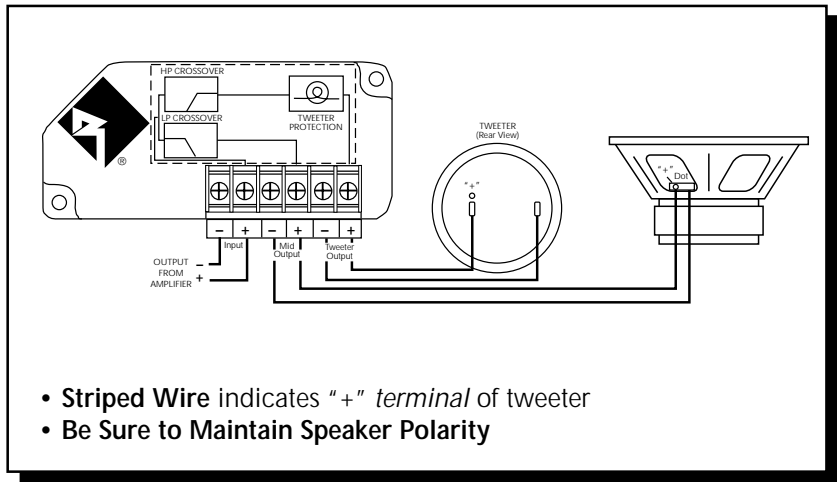



Bandpassing the Midrange

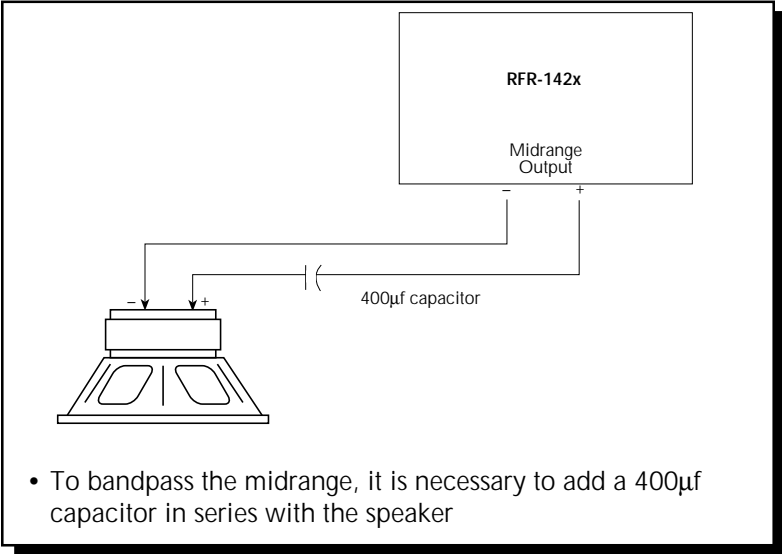

Tweeter Level Matching

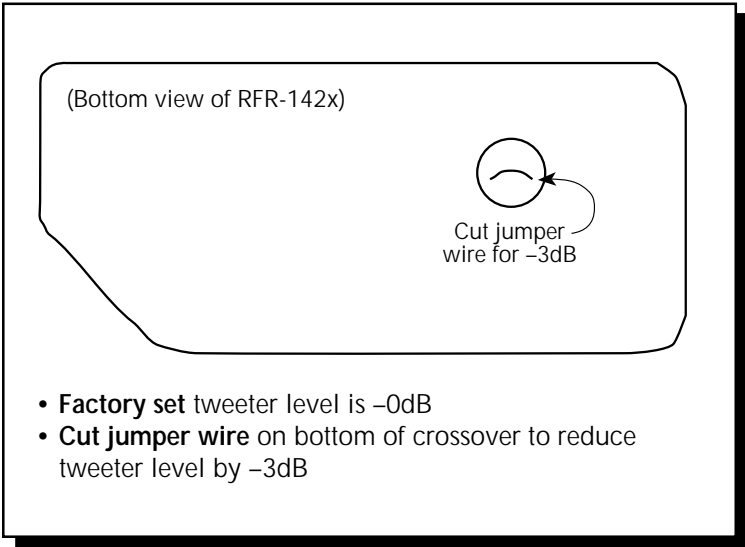

Horizontal Logo Mounting

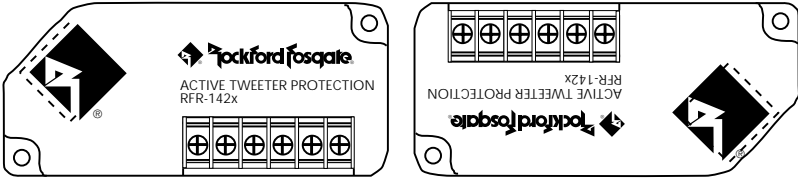

- Configure logo into desired position and snap into place

Vertical Logo Mounting

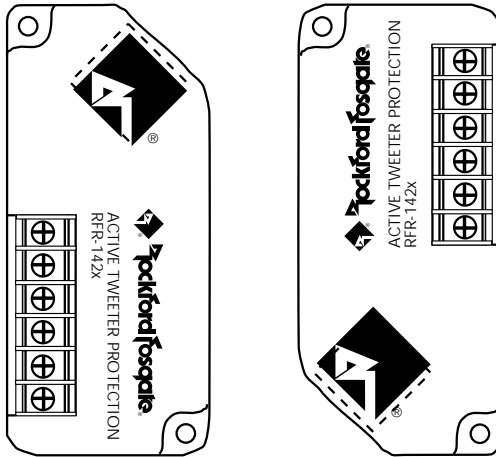

- Configure logo into desired position and snap into place

TROUBLESHOOTING

Symptom	Diagnosis	Remedy
No sound from speakers	Wires between amplifier, crossover and speakers not connected properly.	Check and repair or replace wiring as needed.
	Amplifier has no output.	Check system with known working amplifier and repair or replace as needed.
	Speaker wires are shorted to each other or to the chassis of the vehicle.	Check for shorts in the wiring with a volt/ohm meter and repair or replace wires as needed
	Speakers are blown.	Check system with known working speaker and repair or replace as needed.
Distorted sound from speakers	Incorrect wiring between crossover and speakers	Check wiring and repair or replace as needed.
Tweeters "burn up" easily	Excessive clipping from amplifier	Check gain settings on amplifier and readjust as necessary
	Equalizer in system (if available) has excessive boost in the high frequency range	Check settings on equalizer and readjust as necessary

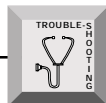

Symptom	Diagnosis	Remedy
Engine Noise from One or More Speakers	Speaker wires shorted to chassis of vehicle.	Check for shorts in the wiring with a volt/ohm meter and repair or replace wires as needed.
	Speaker wires are routed near radiated noise source. (Power cables, vehicle computers, etc.)	Re-route speaker wiring away from noise sources. (Refer to the Installation Considerations section of this manual.)
	Crossover is mounted near radiated noise source. (Power cables, vehicle computers, etc.)	Move crossovers away from noise sources. (Refer to the Installation Considerations section of this manual.)

- If noise persists, see your local Authorized Rockford Fosgate Dealer

SPECIFICATIONS

Model	RFR-14	RFR-1404	RFR-1405	RFR-1406
Freq. Response	3kHz-20kHz	85Hz-9kHz	70Hz-7kHz	65Hz-6kHz
Power Handling (RMS)	100 Watts*	100 Watts	120 Watts	120 Watts
Nom. Impedance	4Ω	4Ω	4Ω	4Ω
Sensitivity (1W/1M)	94dB	89dB	89dB	93dB
Fs (Hz)	1200Hz	85Hz	70Hz	65Hz
Mounting Diameter	Refer to drawing	3 ¹³ / ₁₆ " (96.8mm)	4 ⁷ / ₈ " (123.8mm)	5 ⁵ / ₈ " (142.9mm)
Mounting Depth	Refer to drawing	2 ⁵ / ₃₂ " (54.8mm)	2 ²¹ / ₃₂ " (67.5mm)	2 ³¹ / ₃₂ " (75.4mm)

*Power ratings (PE) is established with recommended filter network.

Model	RFR-142x
Crossover Frequency	3kHz @ 4Ω
Crossover Slope	18dB/octave High-Pass 12dB/octave Low-Pass
Protection Circuitry	Optical Compression
Crossover Alignment	Butterworth
Zobel Network	Effective @ 5.2kHz
Series Notch Filter	Effective @ 2.6kHz
Tweeter Level Matching	Factory set -0dB User selectable -3dB

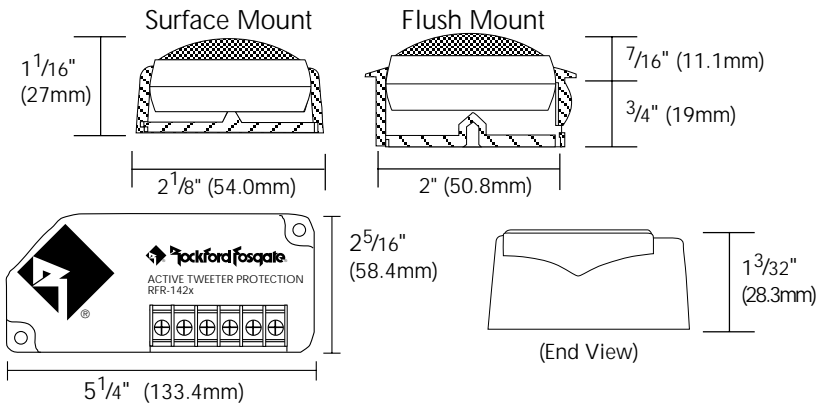

(Specifications are subject to change without notice)

LIMITED WARRANTY INFORMATION

Rockford Corporation offers a limited warranty on Rockford Fosgate products on the following terms:

- **Length of Warranty**

- | | |
|-------------------------|--|
| 1 year on speakers | 30 days on speaker B-stock (receipt required) |
| 3 years on electronics | 90 days on electronic B-stock (receipt required) |
| 2 years on source units | |

- **What is Covered**

This warranty applies only to Rockford Fosgate products sold to consumers by Authorized Rockford Fosgate Dealers in the United States of America or its possessions. Product purchased by consumers from an Authorized Rockford Fosgate Dealer in another country are covered only by that country's Distributor and not by Rockford Corporation.

- **Who is Covered**

This warranty covers only the original purchaser of Rockford product purchased from an Authorized Rockford Fosgate Dealer in the United States. In order to receive service, the purchaser must provide Rockford with a copy of the receipt stating the customer name, dealer name, product purchased and date of purchase.

- **Products found to be defective** during the warranty period will be repaired or replaced (with a product deemed to be equivalent) at Rockford's discretion.

- **What is Not Covered**

1. Damage caused by accident, abuse, improper operations, water, theft
2. Any cost or expense related to the removal or reinstallation of product
3. Service performed by anyone other than Rockford or an Authorized Rockford Fosgate Service Center
4. Any product which has had the serial number defaced, altered, or removed
5. Subsequent damage to other components
6. Any product purchased outside the U.S.
7. Any product not purchased from an Authorized Rockford Fosgate Dealer

- **Limit on Implied Warranties**

Any implied warranties including warranties of fitness for use and merchantability are limited in duration to the period of the express warranty set forth above. Some states do not allow limitations on the length of an implied warranty, so this limitation may not apply. No person is authorized to assume for Rockford Fosgate any other liability in connection with the sale of the product.

- **How to Obtain Service**

Please call 1-800-669-9899 for Rockford Customer Service. You must obtain an RA# (Return Authorization number) to return any product to Rockford Fosgate. You are responsible for shipment of product to Rockford.

Ship to: **Electronics**
Rockford Corporation
Warranty Repair Department
2055 E. 5th Street
Tempe, AZ 85281
RA#: _____

Ship to: **Speakers**
Rockford Acoustic Design
(Receiving-speakers)
609 Myrtle N.W.
Grand Rapids, MI 49504
RA#: _____



LEA DETENIDAMENTE LAS SIGUIENTES INSTRUCCIONES DE INSTALACIÓN DEL PRODUCTO.

INTRODUCCIÓN

Este manual contiene información sobre la construcción, instalación y funcionamiento de los sistemas Punch Power. Le recomendamos que conserve el manual para futuras consultas.

Es preferible que la instalación de sistema Punch Power sea realizada por un distribuidor autorizado Rockford Fosgate. Si prefiere realizar la instalación usted mismo, asegurese de leer el manual en su totalidad antes de comenzar.

MONTAJE

- Le mejor interacción entre tweeter y medio se consigue si no están separados entre si más de 5 centímetros. (Figura 1)

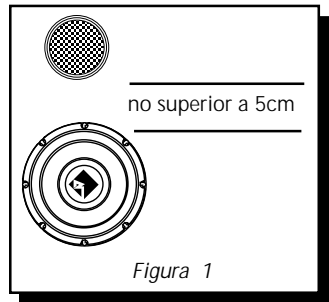

INSTALACIÓN

Montaje del altavoz de medios

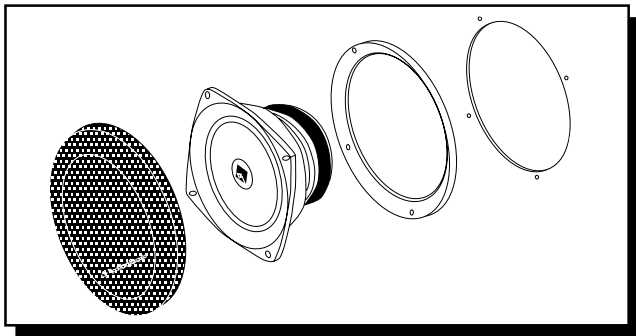
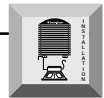

1. Corte el agujero para el medio/woofer.
 - Par el RFR-1404, corte un circulo de 96.8mm de diámetro
 - Par el RFR-1405, corte un circulo de 123.8mm de diámetro
 - Par el RFR-1406, corte un circulo de 142.9mm de diámetro

2. Use los anillos de montaje de plástico como plantilla. Marque la posición de los tornillos de anclaje.
3. Quite el anillo y perfore los agujeros con una broca de 1/8".
4. Pase el cable de altavoz a través del agujero.
5. Instale los clips para tornillo. Monte el anillo de montaje sobre el agujero.
6. Conecte los cables observando la polaridad. Mantenga los cables alejados de partes móviles o cortantes.
7. Asegure el altavoz en la abertura con los tornillos. **Tenga la precaución de no doblar el marco del altavoz en este proceso.**
8. Presione la rejilla en el anillo de montaje.

Montaje en Superficie

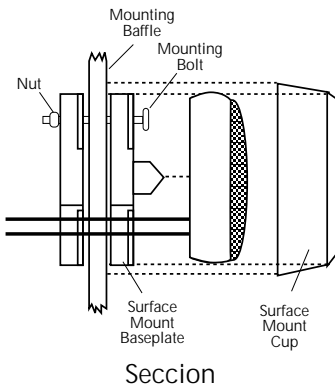

Seccion

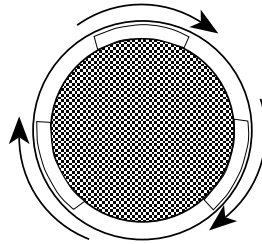

Vista Frontal
(Gire en el sentido contrario a las agujas del reloj para fijar)

- Use la base extra cuando monte el tweeter en una superficie que necesite refuerzo.

Montaje Empotrado

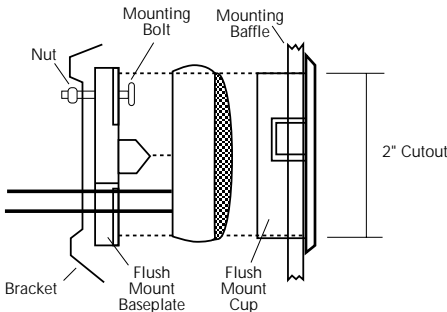

Seccion

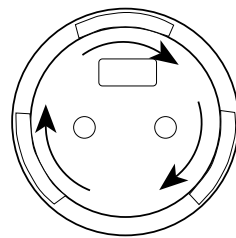

Vista de Atrás
(Gire en el sentido contrario a las agujas del reloj para fijar)



Paso Banda Para del Medio

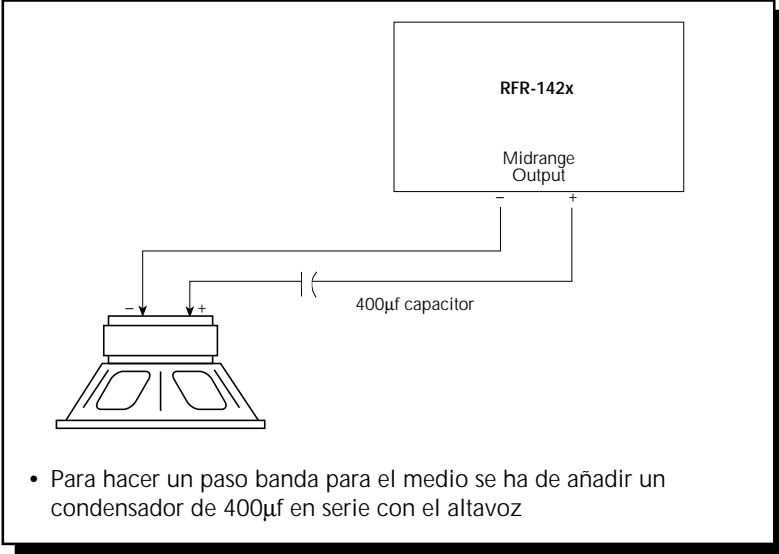

Ajuste de Nivel del Tweeter

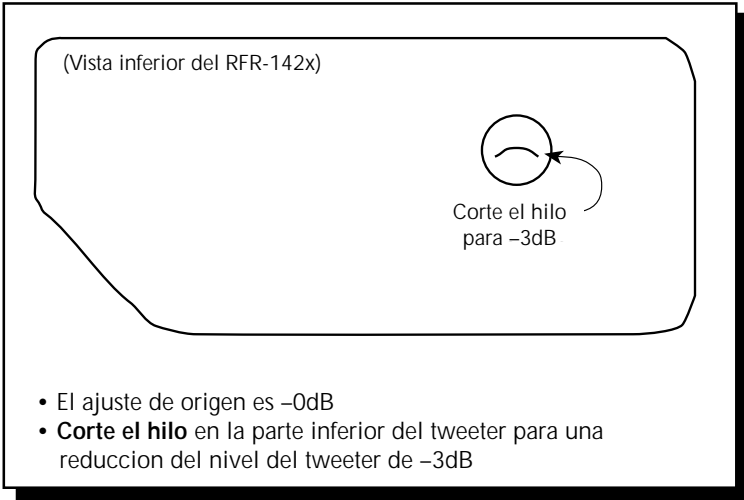

Veillez lire les instructions suivantes pour l'installation de ces produits.

INTRODUCTION

Ce manuel contient des informations sur les caractéristiques et l'installation des systèmes Punch Power. Nous vous proposons de garder ce manuel pour toute référence future.

Nous vous recommandons vivement de faire installer votre système Punch Power par un dealer agréé Rockford Fosgate. Si vous choisissez d'installer le système vous même, assurez-vous de lire ce manuel entièrement avant de commencer.

FRANCAIS

EMPLACEMENT DE MONTAGE

- Pour bénéficier d'une harmonie maximum entre le médium et l'aigu l'éloignement entre ces deux haut-parleurs devrait être de moins de 5 cm entre les 2 chassis. (Figure 1)

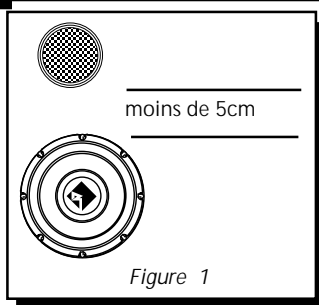

INSTALLATION

Montage du haut-parleur médium

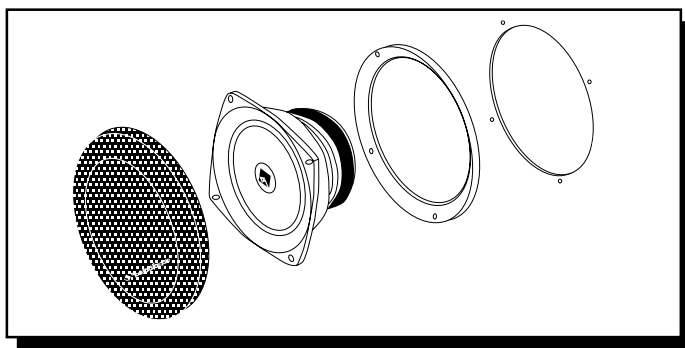

1. Découper un trou adapté au haut-parleur médium/woofer.
 - Pour le RFR-1404, le diamètre du trou est de 96,8mm
 - Pour le RFR-1405, le diamètre du trou est de 123,8mm
 - Pour le RFR-1406, le diamètre du trou est de 142,9mm
2. Placer l'anneau de montage sur le trou et repérer l'emplacement des trous des vis.

3. Retirer l'anneau. Percer les trous des vis en utilisant une mèche de 3mm.
4. Faire passer les fils dans le trou central.
5. Placer l'anneau de montage au-dessus du trou central.
6. Connecter les fils au haut-parleur en respectant les polarités. Eloigner les fils de toute partie tranchante ou mobile du véhicule.
7. Placer le haut-parleur au-dessus du trou central. Visser le haut-parleur dans son emplacement. **Faire attention à ne pas tordre le châssis du haut-parleur durant cette étape de montage.**
8. Mettre la grille dans l'anneau de montage.

Montage en surface du tweeter

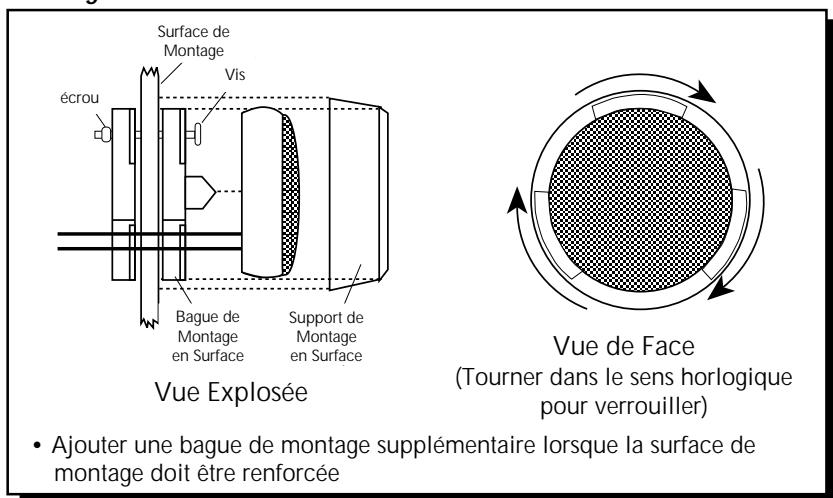

Montage en affleurement du tweeter

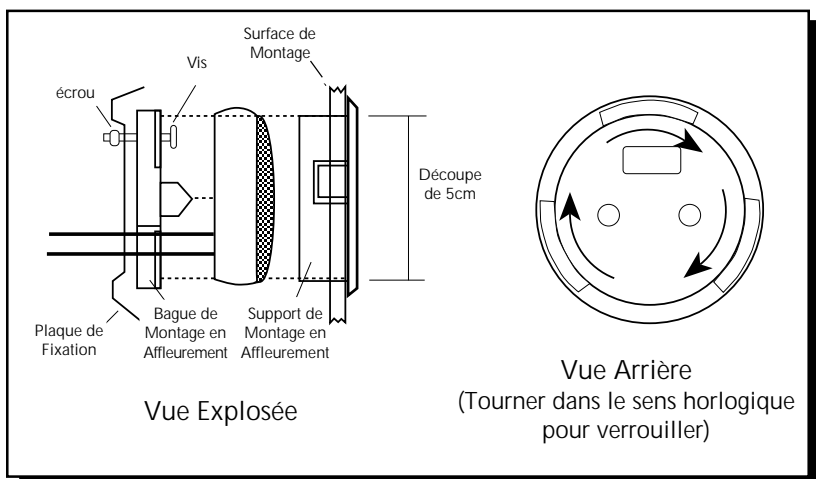

Bandpassing the Midrange

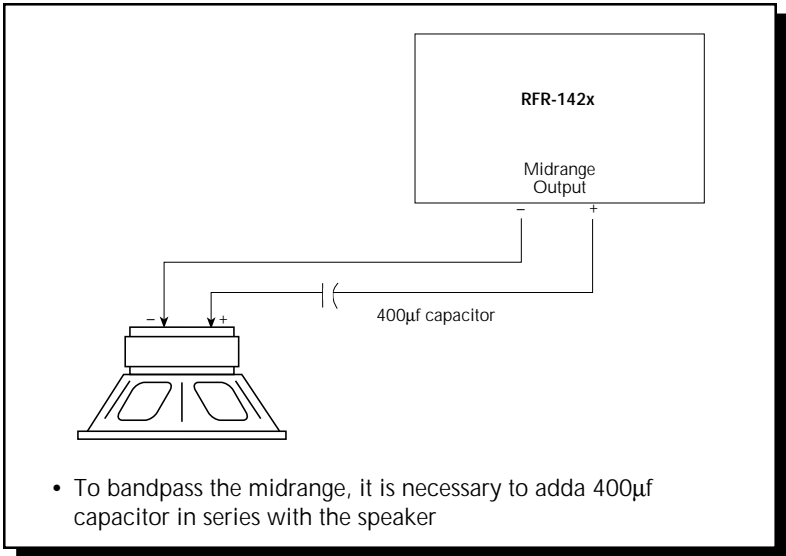

Compensation du Niveau Aigu

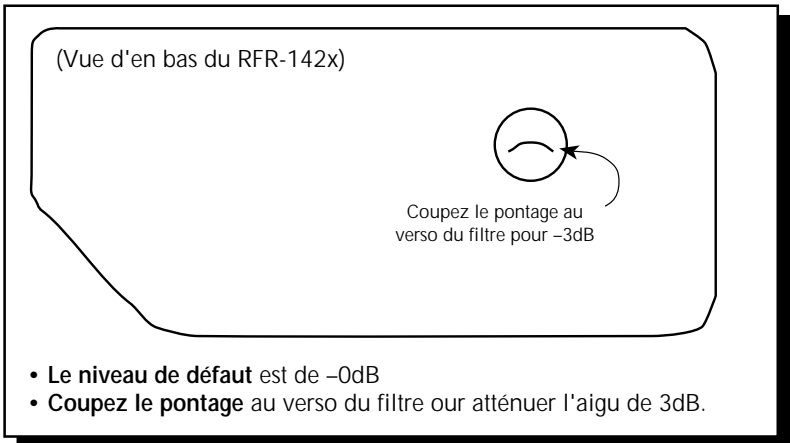

Die folgende Bedienungsanleitung soll Ihnen beim Einbau eine Hilfestellung geben.

ENLEITUNG

Diese Bedienungsanleitung enthält Informationen für den Gebrauch und Einbau des Punch Power Systems. Wir empfehlen, diese auch für Fragen in der Zukunft sorgfältig aufzubewahren.

Es ist empfehlenswert, sich das Punch Power System von einem Autorisierten Rockford Fosgate Fachhändler einbauen zu lassen. Sollten Sie den Einbau jedoch selber vornehmen wollen, so empfehlen wir Ihnen, die Bedienungsanleitung sorgfältig zu lesen.

EINBAUORT

- Für das optimale Zusammenspiel von Mittel- und Hochtönen, sollte der Hochtöner niemals weiter als 5cm vorn Mitteltoner entfernt montiert werden. (Abb. 1)

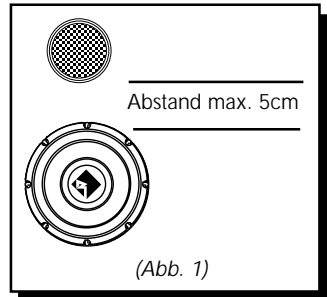

EINBAU

Montage des Mitteltöners

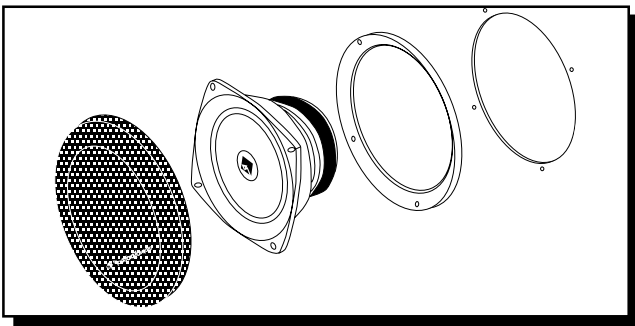

1. Schneiden Sie die richtige Lochgröße für den Mitteltöner oder Midmaß aus.
 - Für den RFR-1404, schneiden Sie ein 96,8cm Ø Loch
 - Für den RFR-1405, schneiden Sie ein 123,8cm Ø Loch
 - Für den RFR-1406, schneiden Sie ein 142,9cm Ø Loch
2. Setzen Sie den Montagering auf das Loch und markieren Sie die Löcher für die Schrauben.

3. Nehmen Sie den Ring wieder ab und bohren Sie dann, mit einem passenden Bohrer, die Schraubenlöcher vor.
4. Führen Sie das Kabel durch das Loch.
5. Plazieren sie den Montagerring über dem Loch.
6. Schließen Sie die Lautsprecherkabel an. Kontrollieren Sie, ob die Polarität stimmt. Stellen Sie sicher, daß das Lautsprecherkabel an keinen scharfen oder sich bewegenden Teilen anliegt.
7. Plazieren Sie den Lautsprecher im Loch und befestigen Sie diesen. Seien Sie dabei sehr vorsichtig, so daß sich der Lautsprecherkorb nicht verzieht.
8. Drücken Sie das Lautsprechergitter im Montagerring fest.

Hochtöner Aufbau-Montage

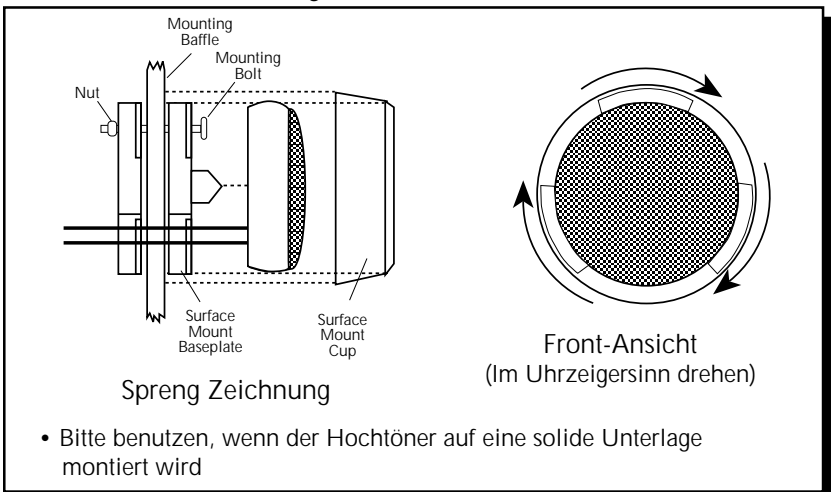

Hochtöner Einbau-Montage

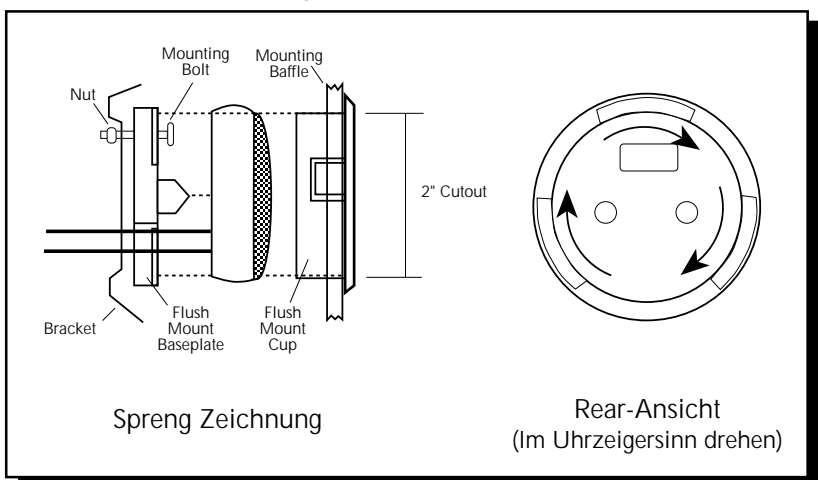

Bandpaß für den Mitteltöner

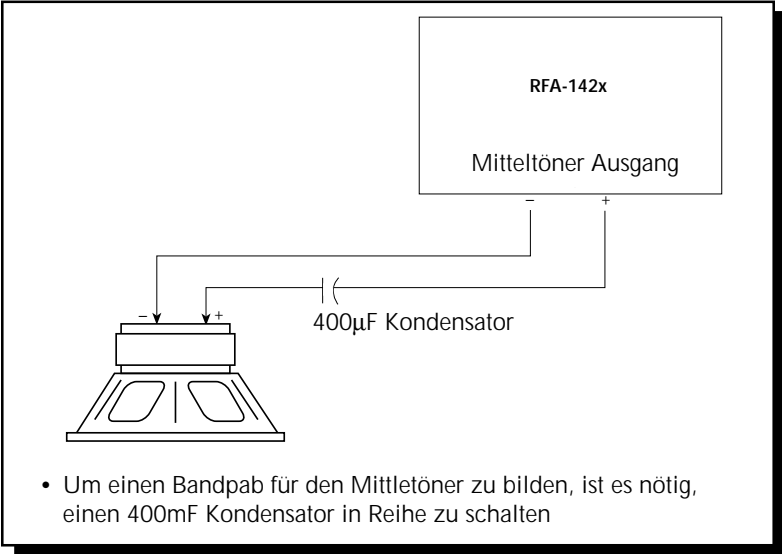

Pegelanpassung für den Hochtöner

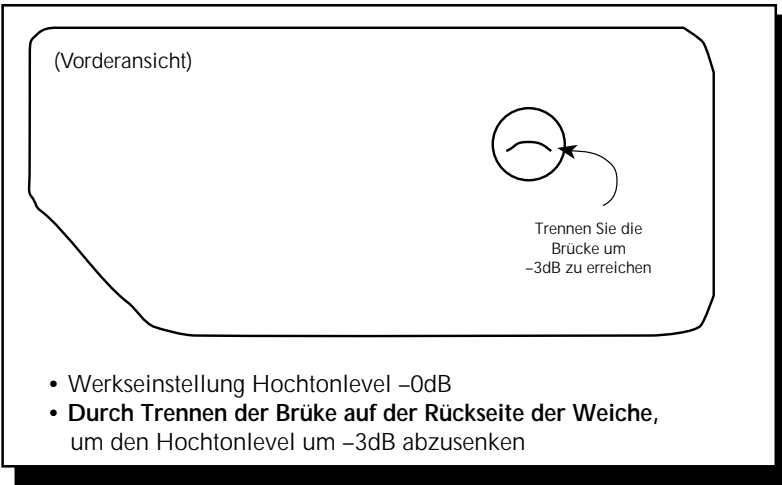

Leggere le istruzioni seguenti prima dell'installazione del prodotto.

INTRODUZIONE

Questo manuale fornisce informazioni sulle caratteristiche e sul l'installazione dei sistemi Punch Power. Vi suggeriamo di conservare questo manuale come riferimento futuro.

Raccomandiamo fortemente che il sistema sia installato dal vostro rivenditore Rockford Fosgate. Se scegliete di procedere con l'installazione da soli, leggete attentamente tutto il manuale prima di proseguire.

POSIZIONAMENTO

- Per ottenere la miglior integrazione tra tweeter e midrange, vi suggeriamo di posizionare i due componenti a meno di 5 cm tra loro. (Figura 1)

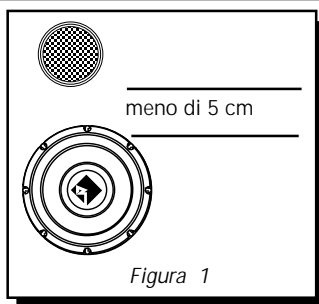

INSTALLAZIONE

Installazione del Midrange

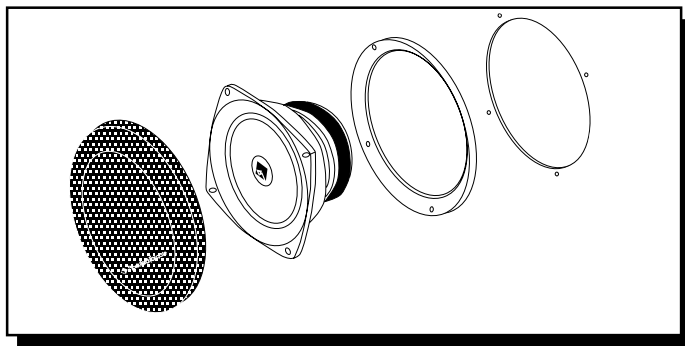

1. Praticate un foro del diametro corretto per il midrange/woofer
 - 96,8mm per RFR-1404
 - 123,8mm per RFR-1405
 - 142,9mm per RFR-1406
2. Posizionate l'anello della griglia sul foro e segate la posizione delle viti.

3. Togliete l'anello e forate il pannello con una puna da 3,5mm.
4. Passate i cavi attraverso il foro.
5. L'anello della griglia sopra il foro dell'altoparlante.
6. Collegate i cavi assicurandovi di osservare la corretta polarità. Assicuratevi di mantenere i cavi lontano da parti in movimento o strutture taglienti.
7. Posizionate l'altoparlante nel foro ed avvitatelo. **Assicuratevi di non piegare il cestello dell'altoparlante.**
8. Incastrate la griglia sull'anello di fissaggio.

Montaggio a Superficie

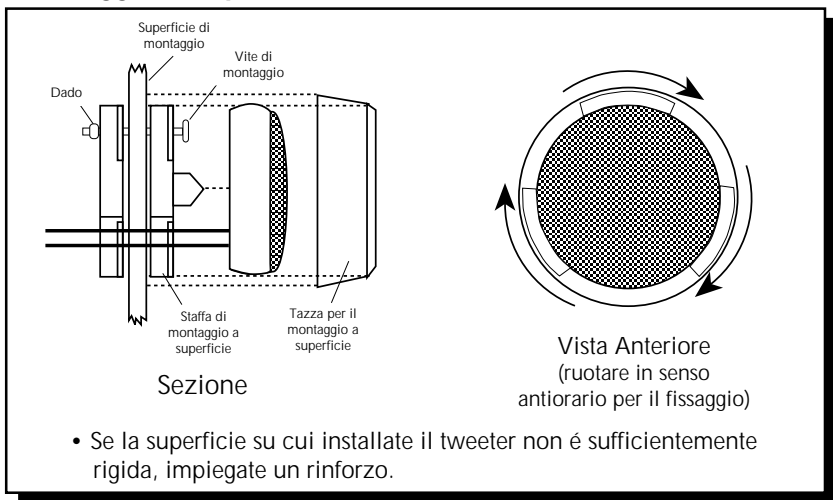

Montaggio ad Incasso

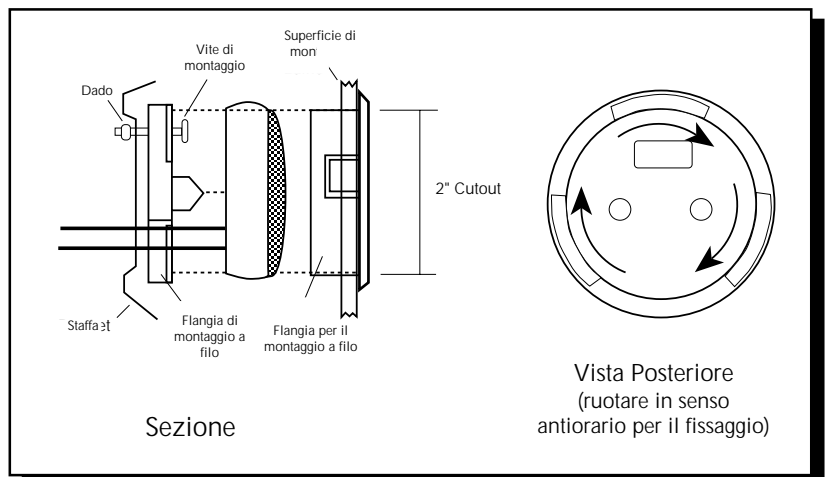

Filtrare passa-banda il midrange

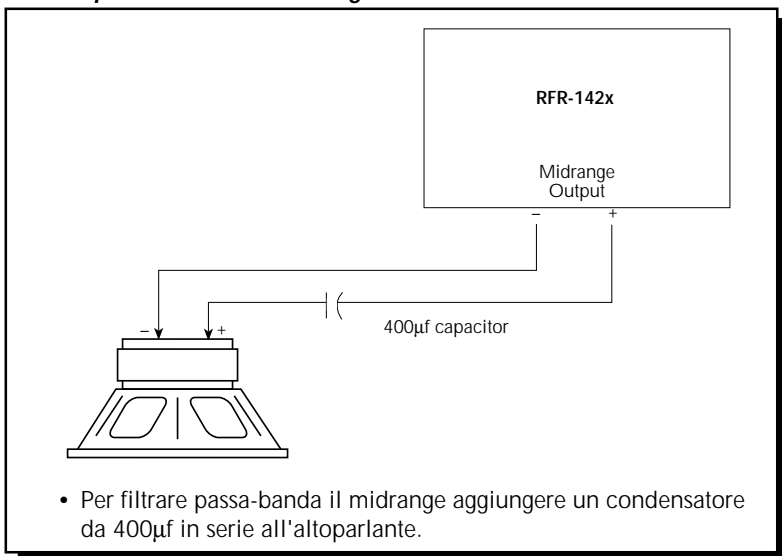

Regolazione del livello di emissione del tweeter

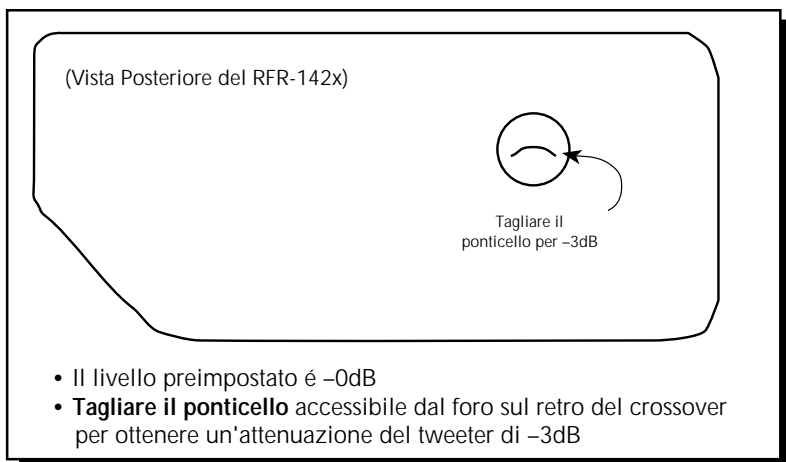

NOTES

NOTES

MADE IN THE USA

This product is designed, developed and assembled in the USA by a dedicated group of American workers. The majority of the components used in the construction of this product are produced by American companies. However, due to the global nature of their manufacturing facilities and the loudspeaker parts industry in general, some parts may be manufactured in other countries.

Rockford Fosgate

Rockford Corporation
546 South Rockford Drive
Tempe, Arizona 85281 U.S.A.
In U.S.A., (602) 967-3565
In Europe, Fax (49) 4207-801250
In Japan, Fax (81) 559-79-1265